

WINMOS Activity 5: Human element and training facilities



REPORT R22042015

OPEN WATER MANOEUVRING TRIALS OF ICEBREAKER KONTIO

13th of May and 27th of December 2014

The sole responsibility of this publication lies with the author. The European Union is not responsible for any use that may be made of the information contained therein.



Co-financed by the European Union
Trans-European Transport Network (TEN-T)

REPORT R22042015 **Open Water Manoeuvring Trials of Icebreaker Kontio**

CUSTOMER Finnish Transport Agency

SUMMARY The manoeuvring characteristics of icebreaker Kontio were measured on two manoeuvring trials. The first trial was executed in the southern Finnish Archipelago close to the island of Utö on 13th of May 2014 and the second trial outside the city of Oulu, in the Bay of Bothnia on 27th of December 2014.

The test programs included two Z-tests, three turning circles extended with pullout tests, four bow thruster tests, a crabbing test and astern tests. Additionally several acceleration and deceleration tests as well as "star" turns were executed in order to measure powertrain responses and ship behaviour in transient states of motion.

Test results indicate that Kontio's manoeuvring performance is within IMO's requirements. The yaw checking ability is average but the turning ability is below average. According to the pullout test results the vessel is marginally course unstable.

The test results show, that Kontio is very course unstable while moving astern and not manageable with the rudders only, without applying bow thruster or main propeller assistance.

Siuntio, 27th of April, 2015

SIMULCO OY

Jaakko Lehtosalo

INTRODUCTION.....	5
TRIAL CONDITIONS.....	5
RECORDED SIGNALS.....	5
RESULTS.....	6
10/10 Z-TEST AT 11 KNOTS.....	8
5/5 Z-TEST AT 11 KNOTS.....	11
35 TURNING CIRCLE STBD.....	14
35 TURNING CIRCLE PORT.....	17
35 TURNING CIRCLE STBD(2).....	20
PULL OUT TEST STBD.....	23
PULL OUT TEST PORT.....	26
PULL OUT TEST STBD(2).....	29
10 Z-TEST WITH BOW THRUSTER AT 4 KNOTS.....	32
20 Z-TEST WITH BOW THRUSTER AT ZERO SPEED.....	35
10 Z-TEST WITH BOW THRUSTER AT 3 KNOTS ASTERN.....	38
5 Z-TEST WITH BOW THRUSTER AT 4 KNOTS ASTERN.....	41
ASTERN TEST.....	44
CRABBING TEST.....	47
ACCELERATION TURNING CIRCLE WITH 1+1 DIESEL GENERATORS.....	52
DECELERATION TURN WITH 1+1 DIESEL GENERATORS.....	56
ACCELERATION TURNING CIRCLE WITH 2+2 DIESEL GENERATORS.....	60
DECELERATION TURN WITH 2+2 DIESEL GENERATORS.....	64
STAR TURN(1).....	68
STAR TURN(2).....	73
STAR TURN(3).....	78

ACCELERATION TEST WITH 1+1 DIESEL GENERATORS.....	83
DECELERATION TEST WITH 1+1 DIESEL GENERATORS.....	88
ACCELERATION TEST WITH 2+2 DIESEL GENERATORS.....	93
DECELERATION TEST WITH 2+2 DIESEL GENERATORS.....	98
DEFINITIONS.....	103

INTRODUCTION

Icebreakers Kontio and the sister ship Otso performed sea trials during their delivery in 1980's. These trials included basic open water manoeuvring tests according to IMO guidance. In order to better understand their manoeuvring performance additional trials were ordered.

The manoeuvring characteristics of icebreaker Kontio were measured on two manoeuvring trials. The first trial was executed in the southern Finnish Archipelago close to the island of Utö on 13th of May 2014 and the second trial outside the city of Oulu, in the Bay of Bothnia on 27th of December 2014.

TRIAL CONDITIONS

On the first trial the draught condition of the ship was 7,0 meters in fore and 7,2 meters in aft. On the second trial the vessel was on even keel measuring 7,4 meters of draught. The water depth in trial areas is over 30 meters, i.e. over four times ship's draught and considered as a deep water condition.

The wind speed and direction were observed during the trials. On both trials the wind was blowing from north, on the first trial wind speed was 6 m/s. On the second trial it was calmer, wind speed was 4 m/s.

RECORDED SIGNALS

The following signals from the integrated navigation system were recorded during the trials:

- GPS time
- GPS latitude and longitude
- GPS speed and course over ground
- Gyro compass heading and rate of turn
- Echo sounder water depth
- Rudder angle
- Wind speed and direction

The following information was video recorded from the engine control screen during the trials:

- Propeller revolutions
- Diesel generator power
- Electrical propulsion motor power

Furthermore, bow thruster revolutions were noted during the thruster trials.

Recorded signals were calculated relative to the mid-point of the ship. Latitude and longitude were converted to X-Y coordinate system.

RESULTS

Track histories presented in this report have the ship symbol plotted in 10 second intervals.

Two conventional Z-tests were executed, one with five degrees of rudder and the other with ten degrees. Yaw checking ability is average. The first overshoot angle in standard 10/10 Z-test is 7,4 degrees (IMO requirement is 10 degrees for a 10/10 -test). The initial turning distance is 1,6 ship lengths (IMO requirement is less than 2,5 times ship length). Results of these Z-tests are on pages 8-13.

Three turning circles with constant propulsion power were performed. The turning circle results show, that the turning ability is below average. The measured advance and tactical diameter at 12 knots are around 330 (3,3 ship lengths) and 420 meters (4,2 ship lengths) at 35 degrees of rudder angle (pages 14-22). These values are within IMO requirements, but not with large margin. IMO's requirements are 4,5 and 5 ship lengths respectively.

Three pull out tests were executed and their results are on pages 23-31. According to the results the vessel is marginally course unstable.

Kontio has one 1720 kW bow thruster. Four thruster tests were made. The procedure on the tests was to deviate ship's heading in both directions. On the first test the ship was moving forward at four knots and the rudder was held midships. Controllability with the

thruster is good (pages 32-34). On the second test the ship was initially still in water. The remaining two tests were performed ship moving astern. At three knots astern speed the ship is still manoeuvrable with the bow thruster (pages 38-40), but at four knots it is getting harder to keep the vessel under control (pages 41-43). The astern test results displayed on pages 44-46 show, that at the speed above four knots astern Kontio is not manageable with the rudders only, without applying bow thruster or main propeller assistance.

Acceleration and deceleration tests (pages 52-67 and 83-102) as well as star turns (pages 68-82) were executed in order to measure powertrain responses and ship behaviour in transient states of motion.

10/10 Z-test at 11 knots			
13.5.2014			
Wind direction [deg]	330	First overshoot angle [deg]	7,4
Wind speed [m/s]	5	Time to check first yaw [s]	24
		Second overshoot angle [deg]	7,1
Initial speed [knots]	11,4	Time to check second yaw [s]	20
Initial heading [deg]	326	Turning rate [deg/s]	0.75
		[deg/min]	45
Initial turning time [s]	27	Time for complete cycle [s]	173

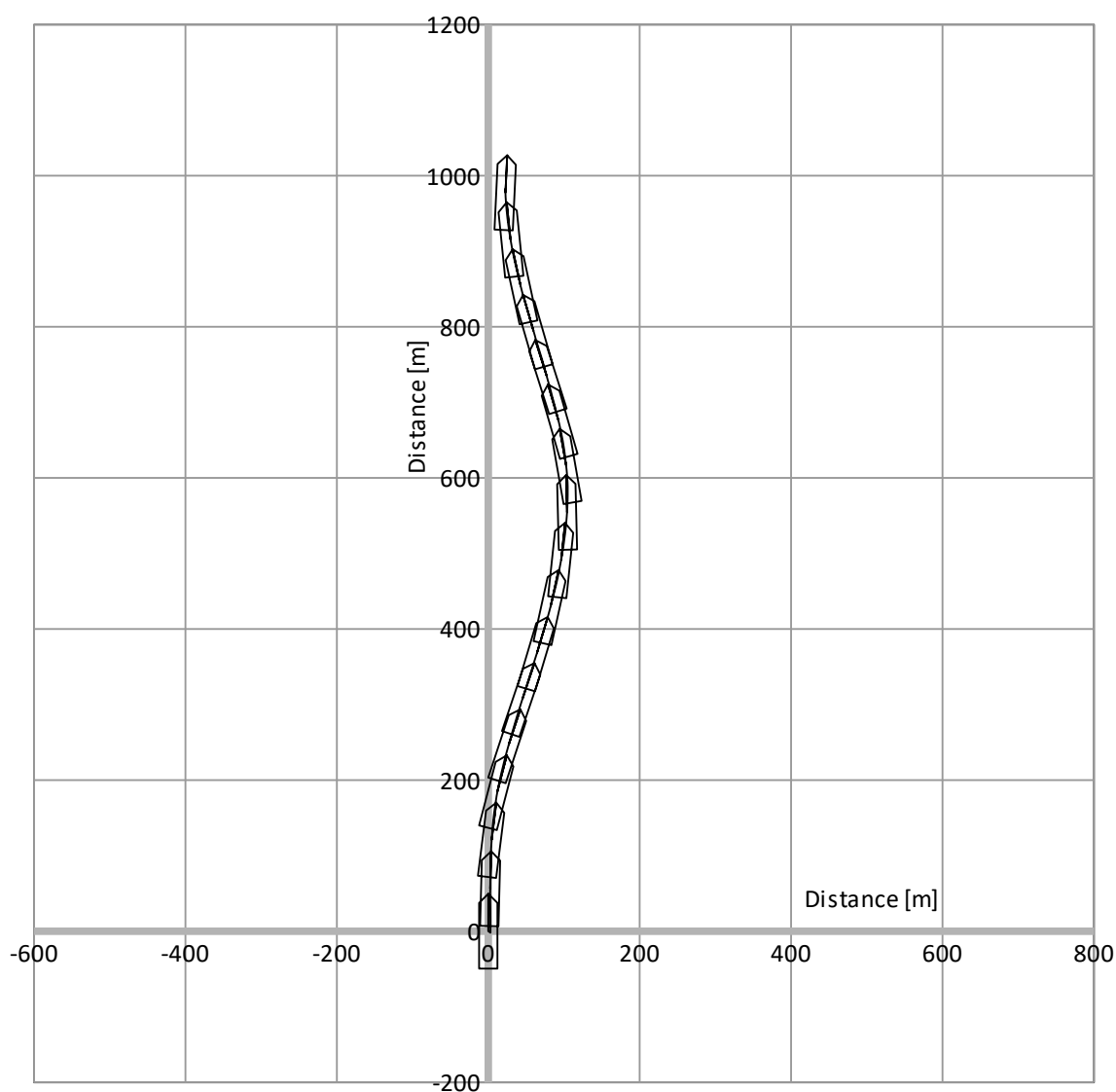

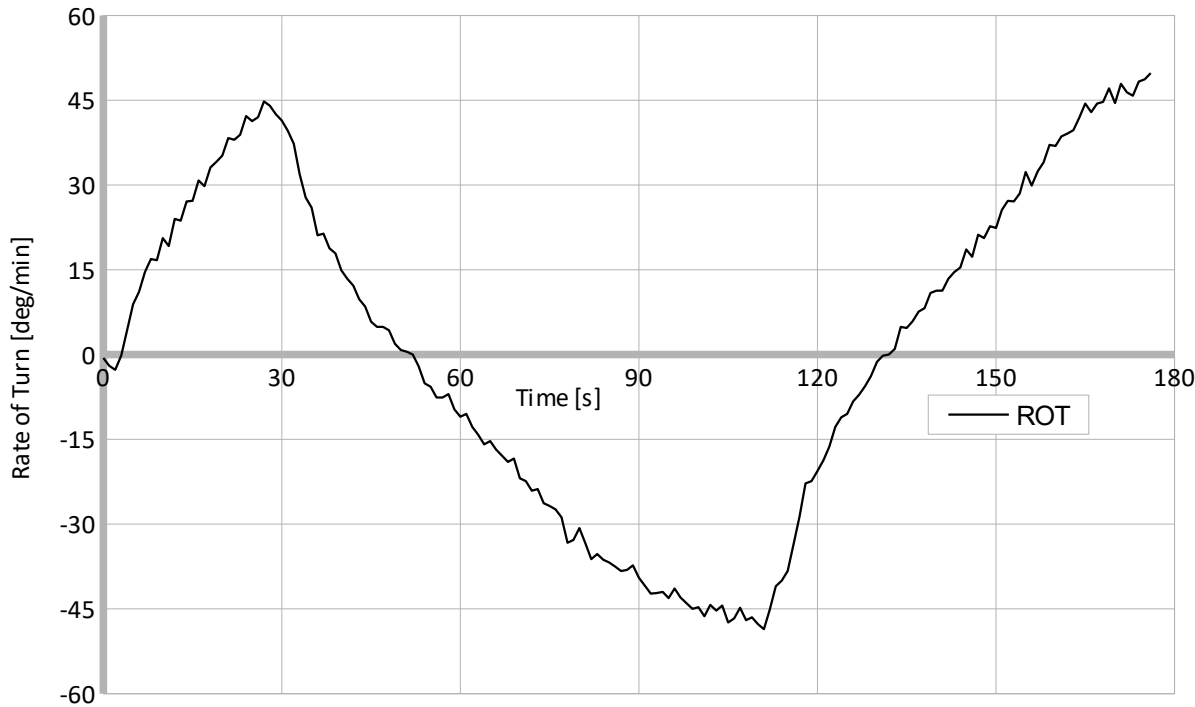
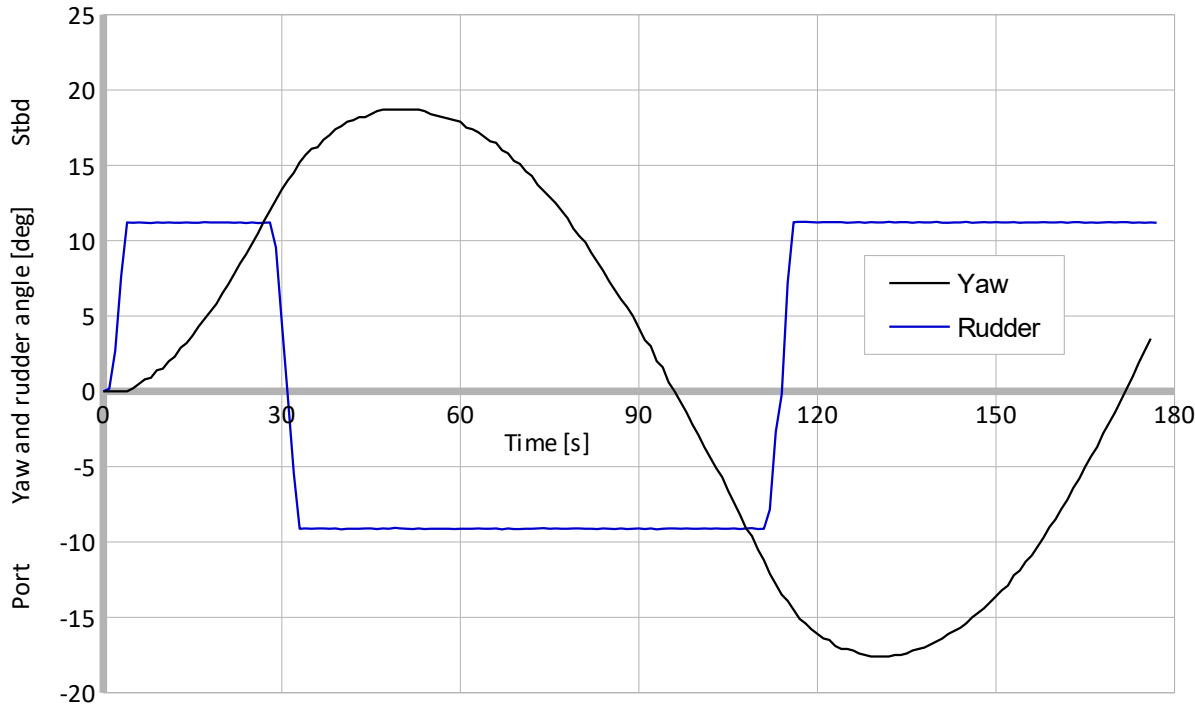

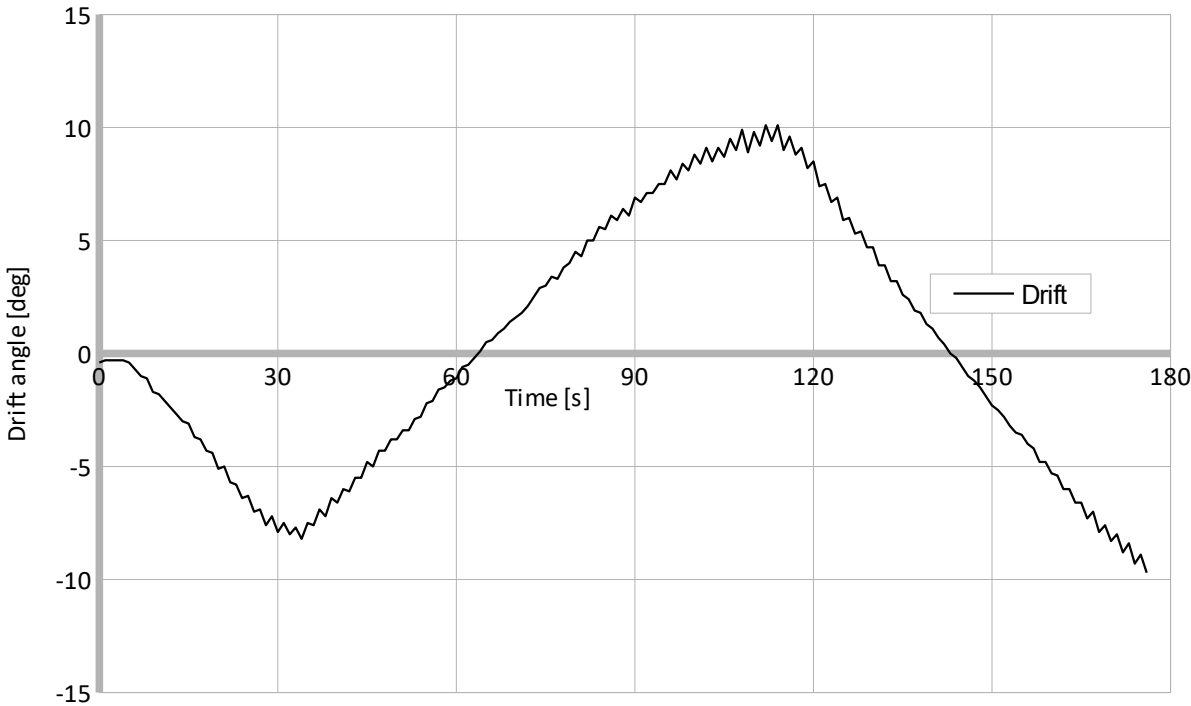
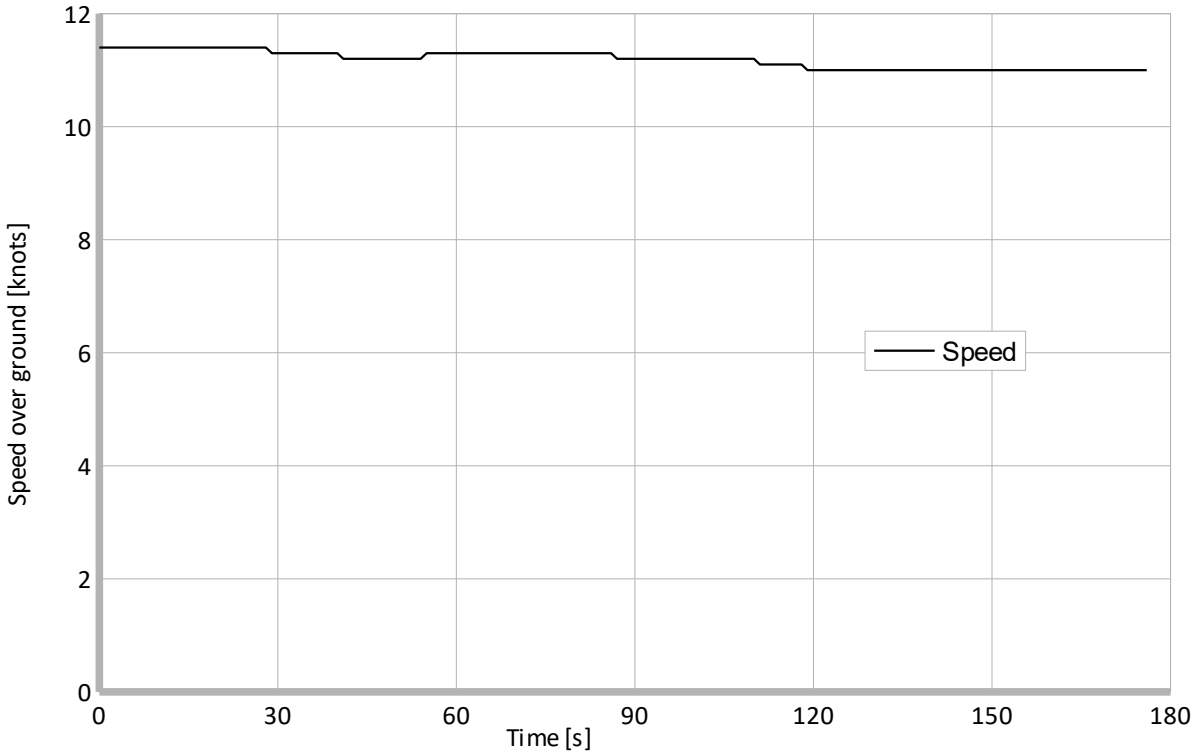

5/5 Z-test at 11 knots			
13.5.2014			
Wind direction [deg]	330	First overshoot angle [deg]	6,1
Wind speed [m/s]	6	Time to check first yaw [s]	34
		Second overshoot angle [deg]	5,4
Initial speed [knots]	11,3	Time to check second yaw [s]	27
Initial heading [deg]	326	Turning rate [deg/s]	0,47
		[deg/min]	28
Initial turning time [s]	22	Time for complete cycle [s]	186

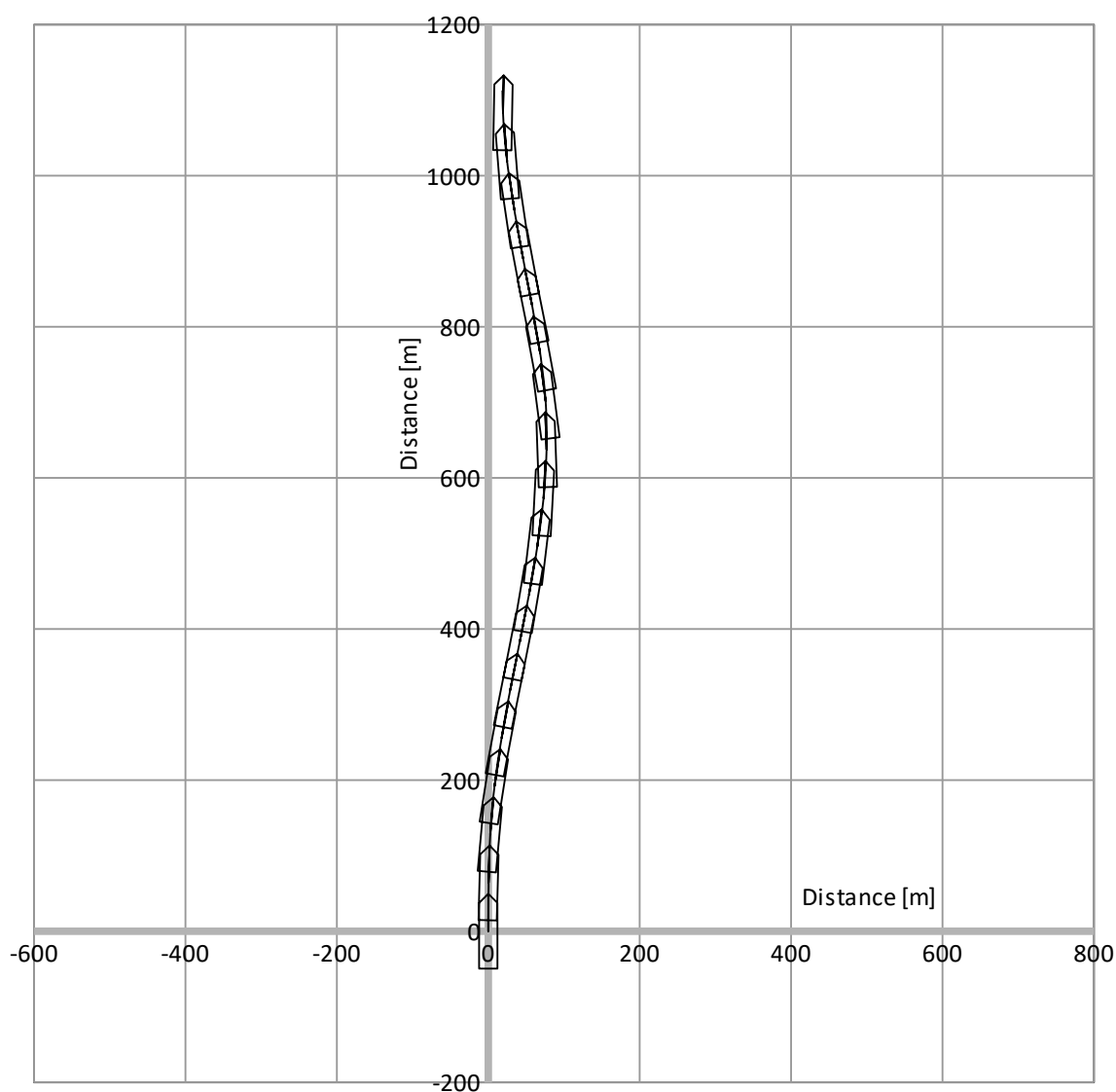

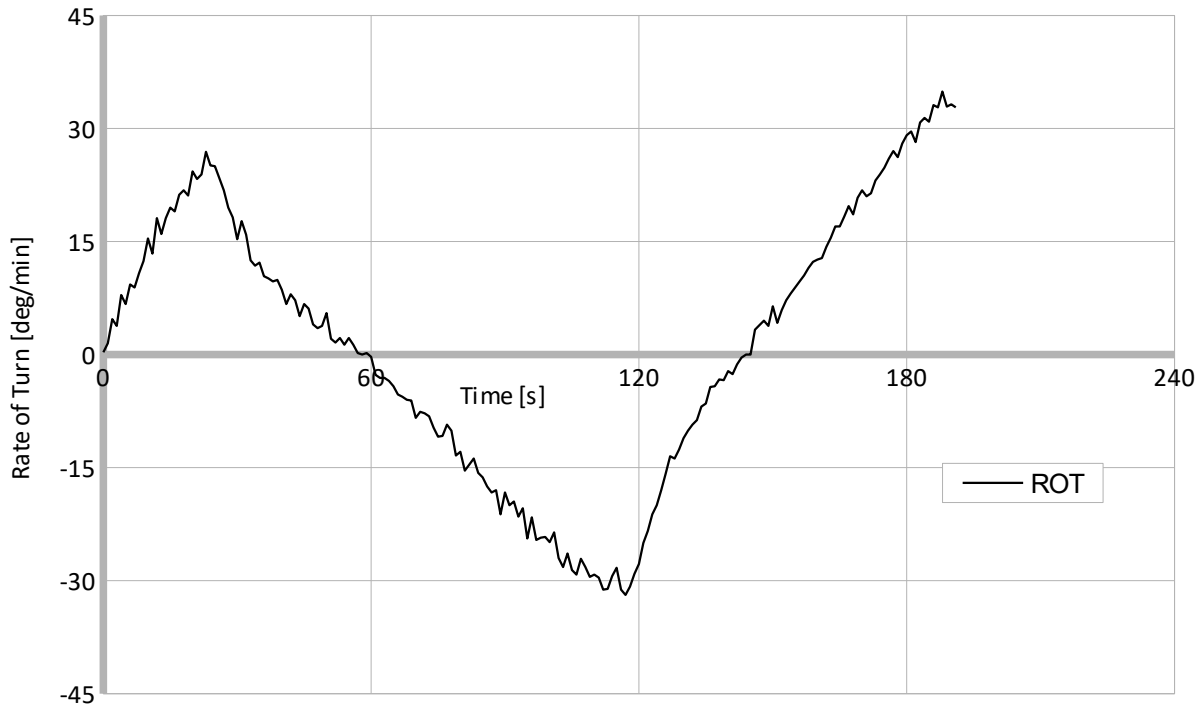
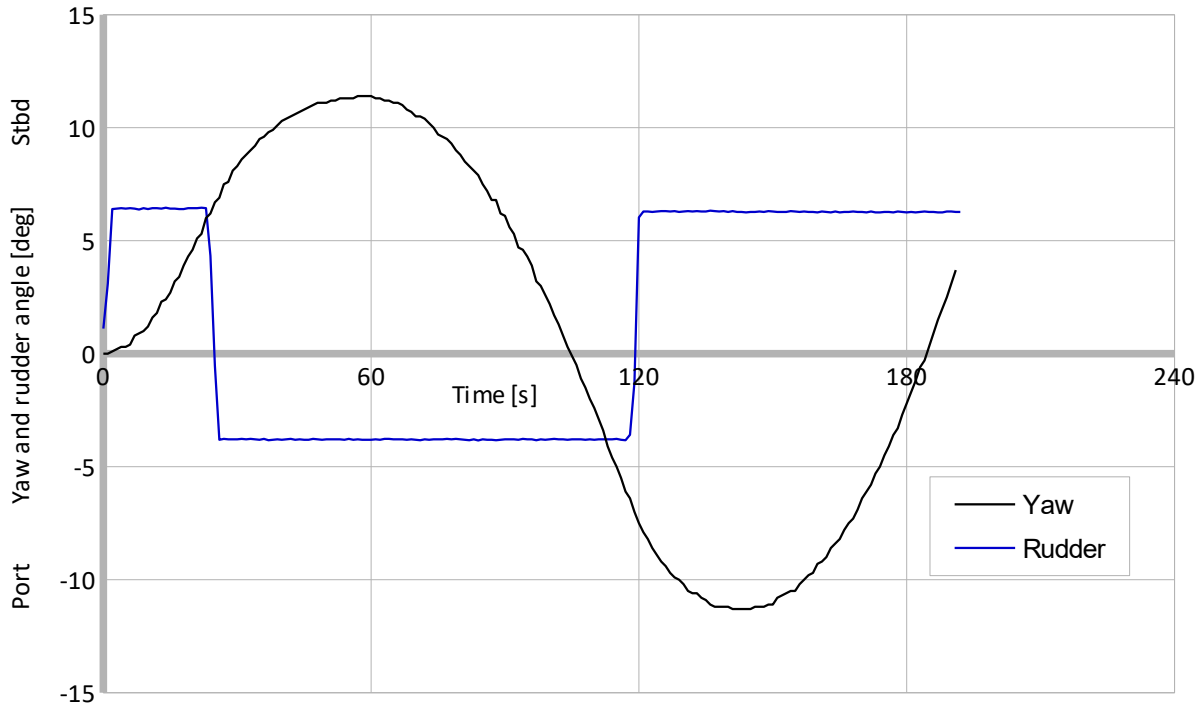

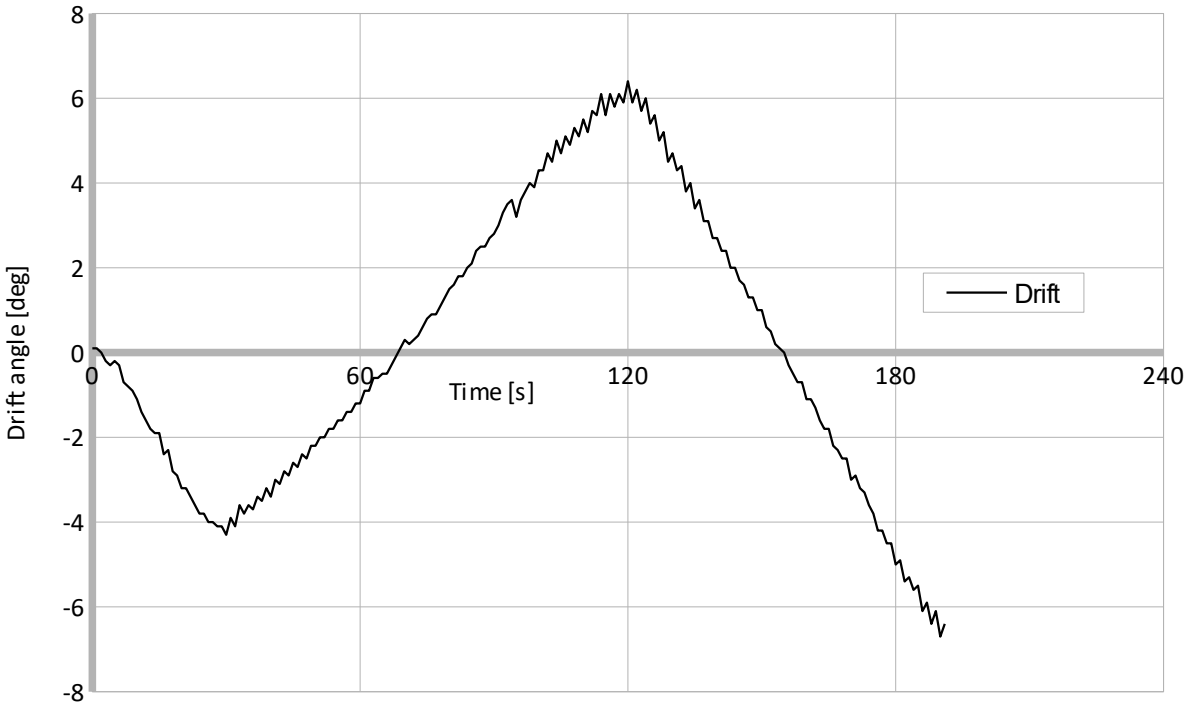
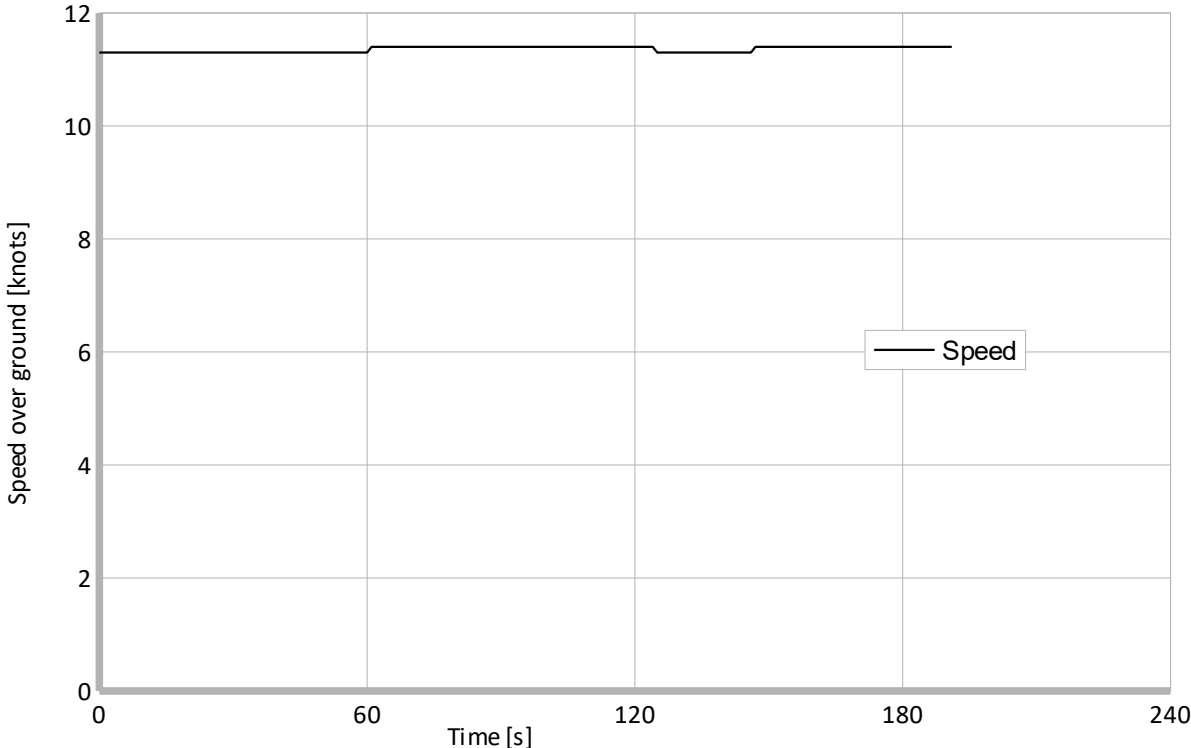

35 turning circle stbd 13.5.2014			
Wind direction [deg]	330	Time to turn 180 degrees [s]	154
Wind speed [m/s]	6	Tactical diameter [m]	407
		Time to turn 360 degrees [s]	319
Initial speed [knots]	11,6	Steady diameter [m]	414
Initial heading [deg]	335	Steady drift [deg]	17
Advance [m]	316	Rate of turn [deg/s]	1,08
		[deg/min]	65
Transfer [m]	178	Steady speed [knots]	7,1
Time to turn 90 degrees [s]	78	Rudder angle [deg]	33

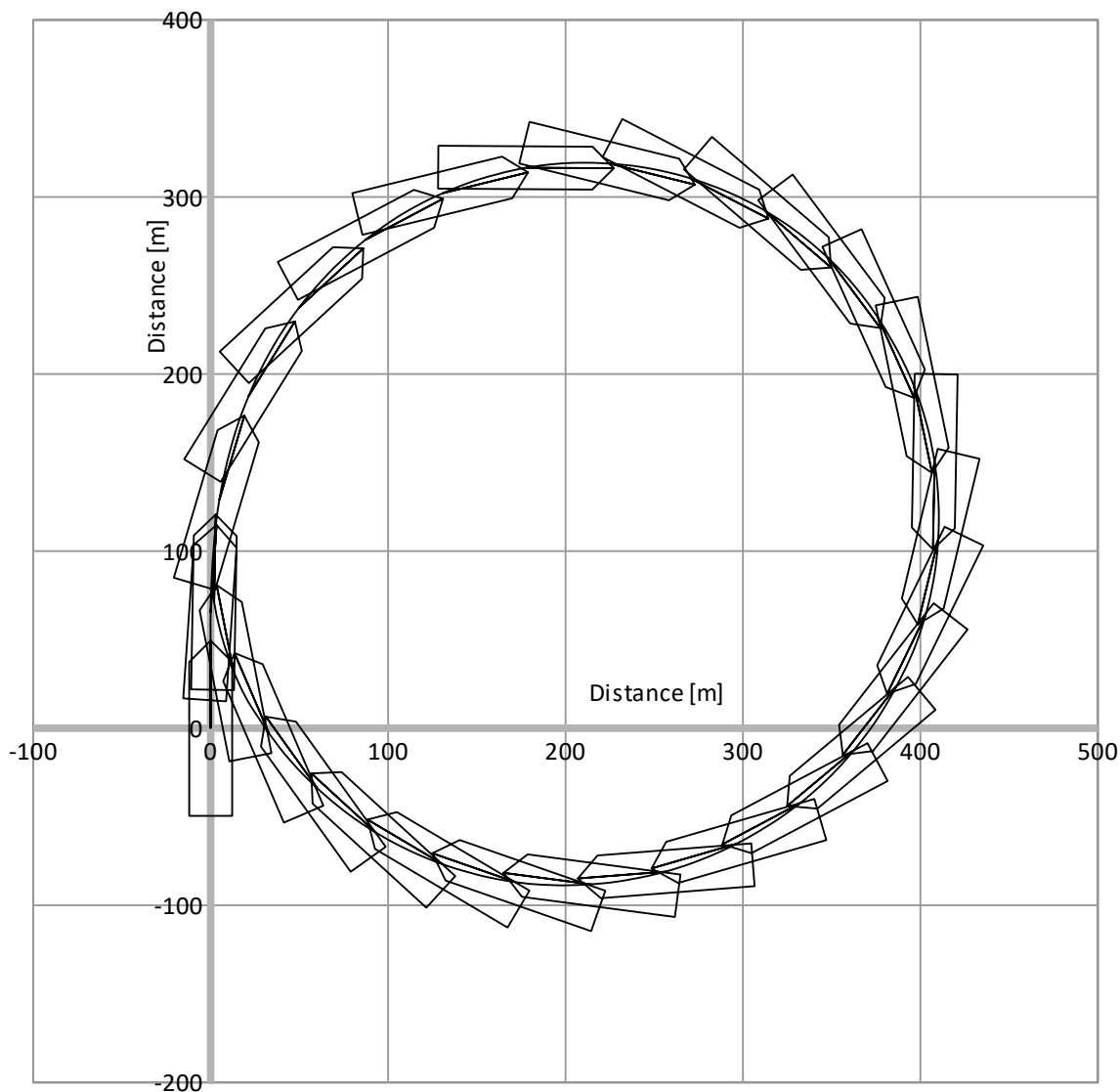

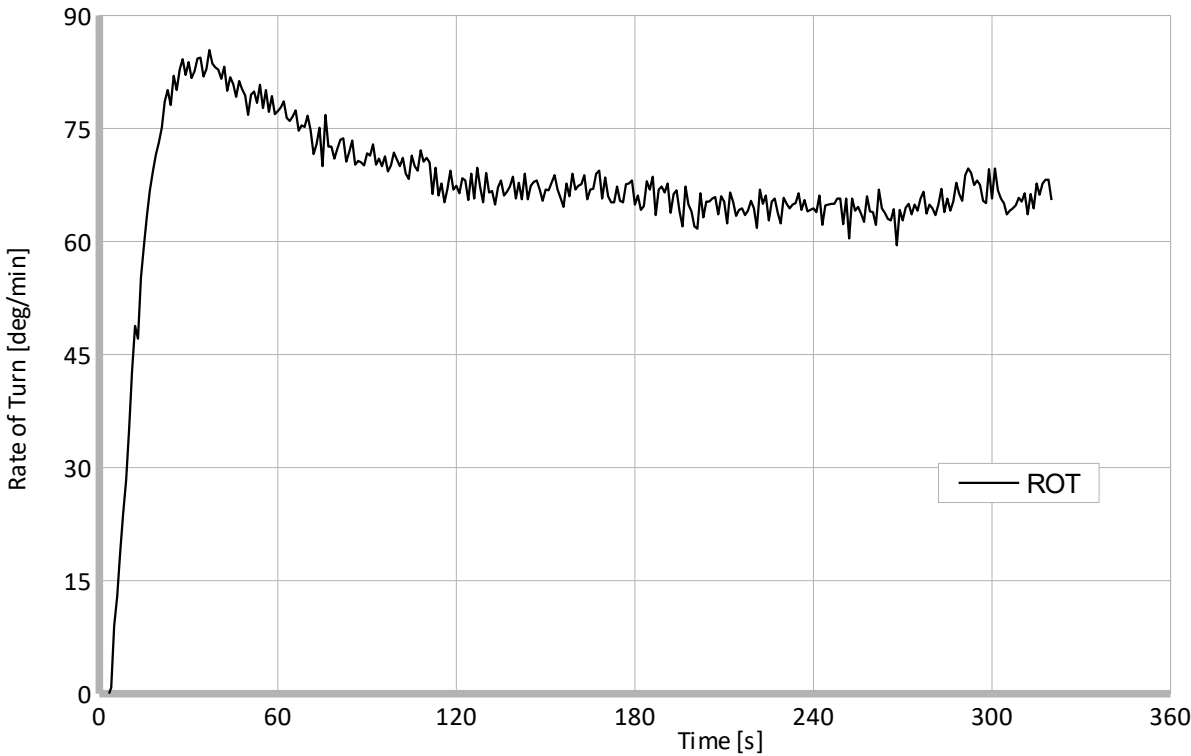
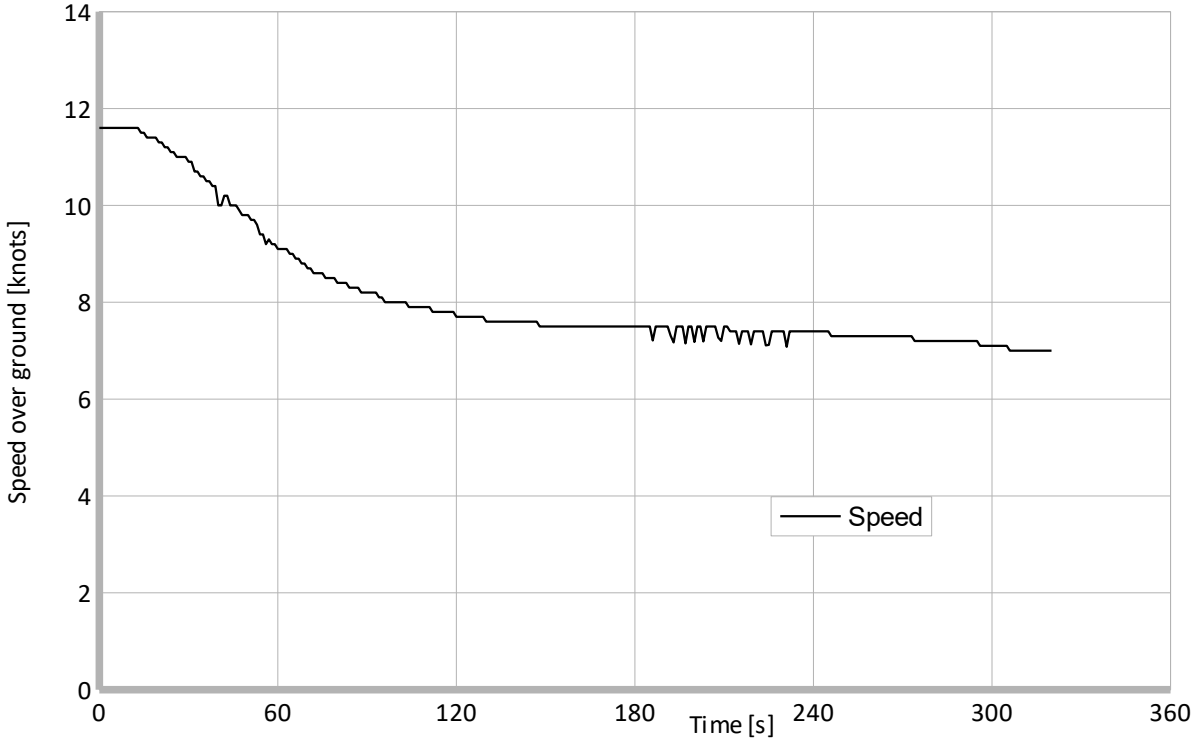

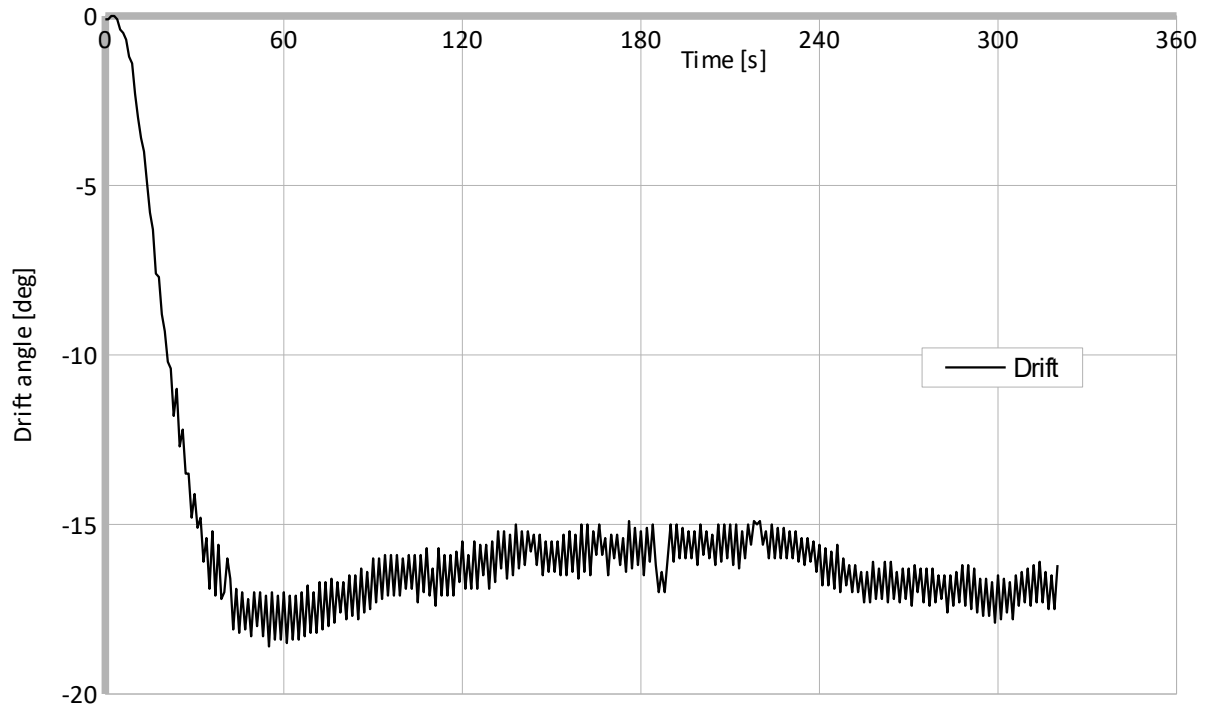

35 turning circle port			
13.5.2014			
Wind direction [deg]	330	Time to turn 180 degrees [s]	164
Wind speed [m/s]	6	Tactical diameter [m]	434
		Time to turn 360 degrees [s]	320
Initial speed [knots]	11,6	Steady diameter [m]	362
Initial heading [deg]	150	Steady drift [deg]	17
Advance [m]	323	Rate of turn [deg/s]	1,10
		[deg/min]	66
Transfer [m]	183	Steady speed [knots]	7,3
Time to turn 90 degrees [s]	81	Rudder angle [deg]	34

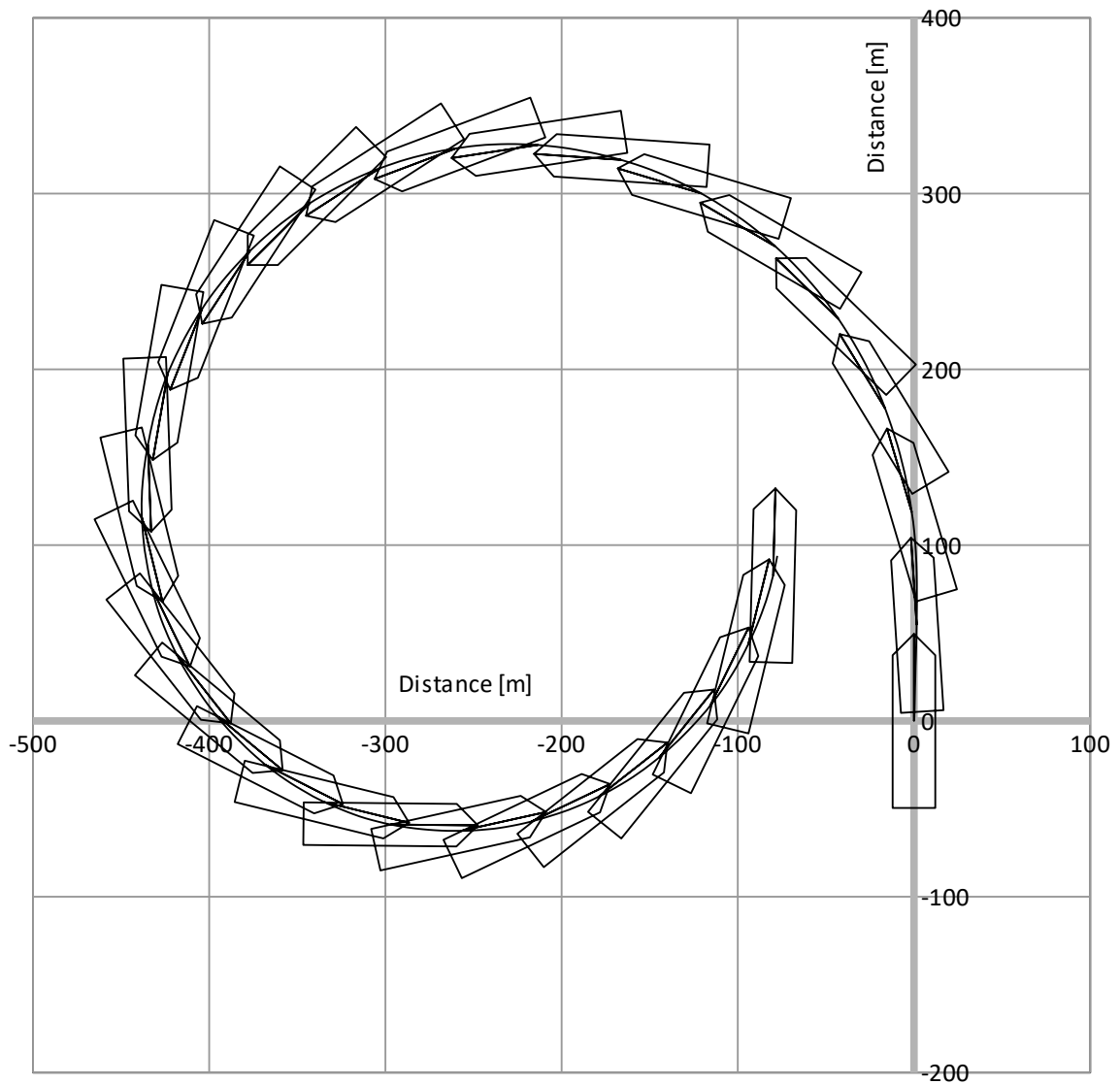

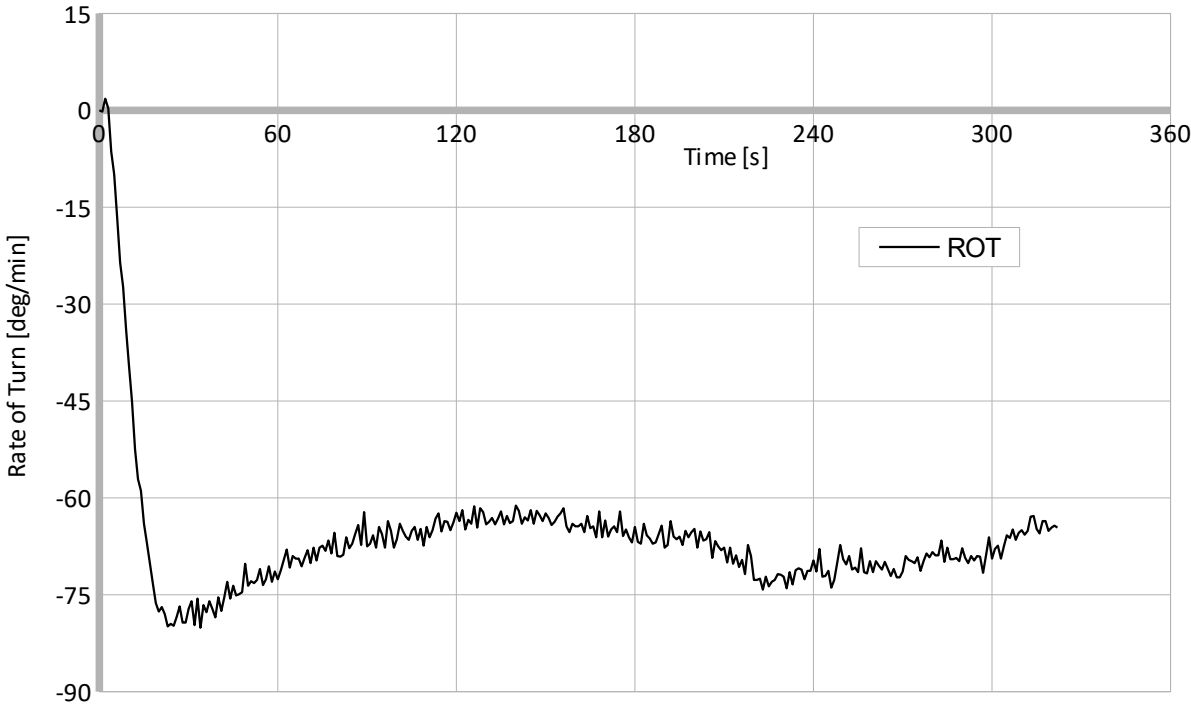
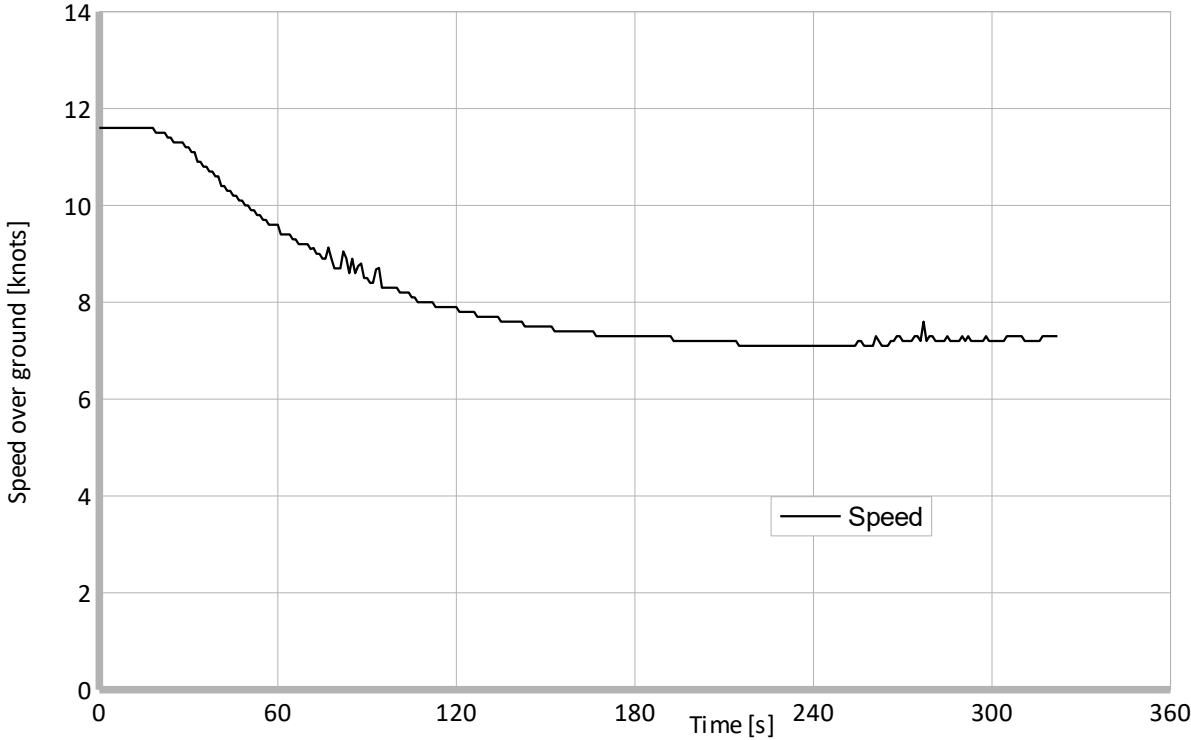

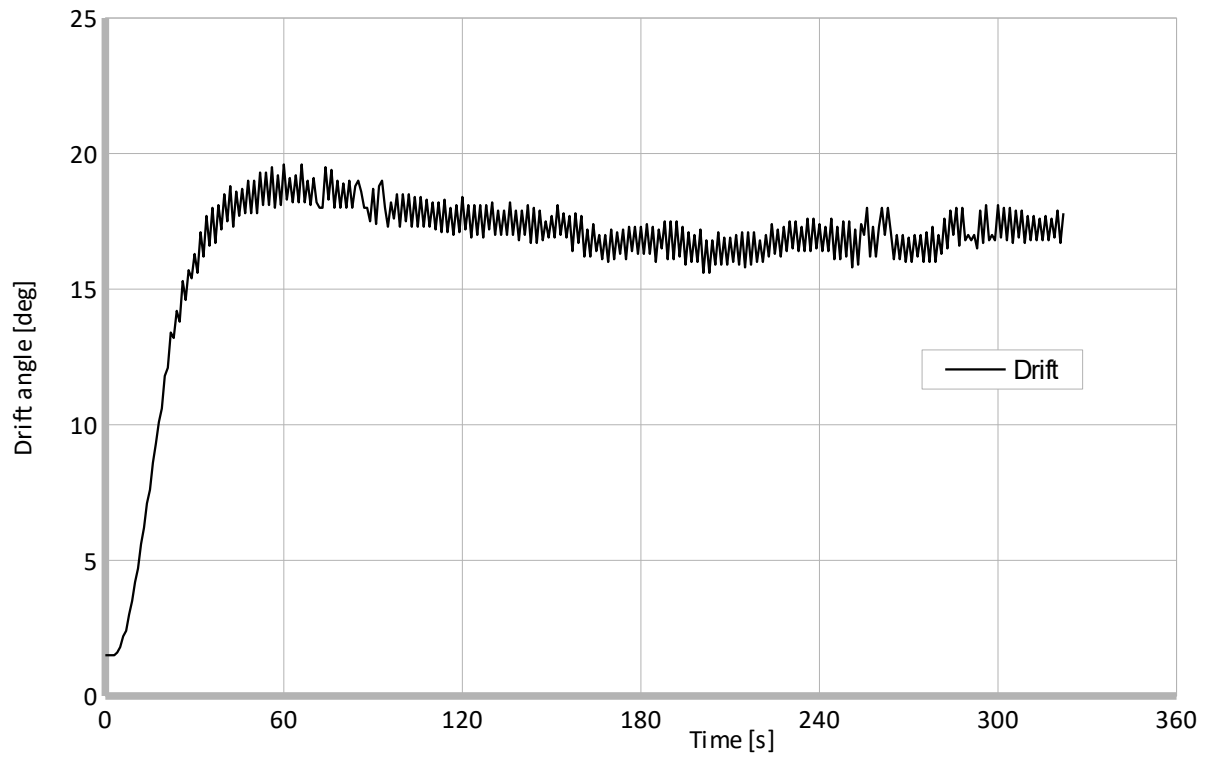

35 turning circle stbd(2)			
13.5.2014			
Wind direction [deg]	330	Time to turn 180 degrees [s]	161
Wind speed [m/s]	6	Tactical diameter [m]	448
		Time to turn 360 degrees [s]	314
Initial speed [knots]	11,9	Steady diameter [m]	352
Initial heading [deg]	150	Steady drift [deg]	16
Advance [m]	334	Rate of turn [deg/s]	1,08
		[deg/min]	65
Transfer [m]	199	Steady speed [knots]	7,1
Time to turn 90 degrees [s]	80	Rudder angle [deg]	33

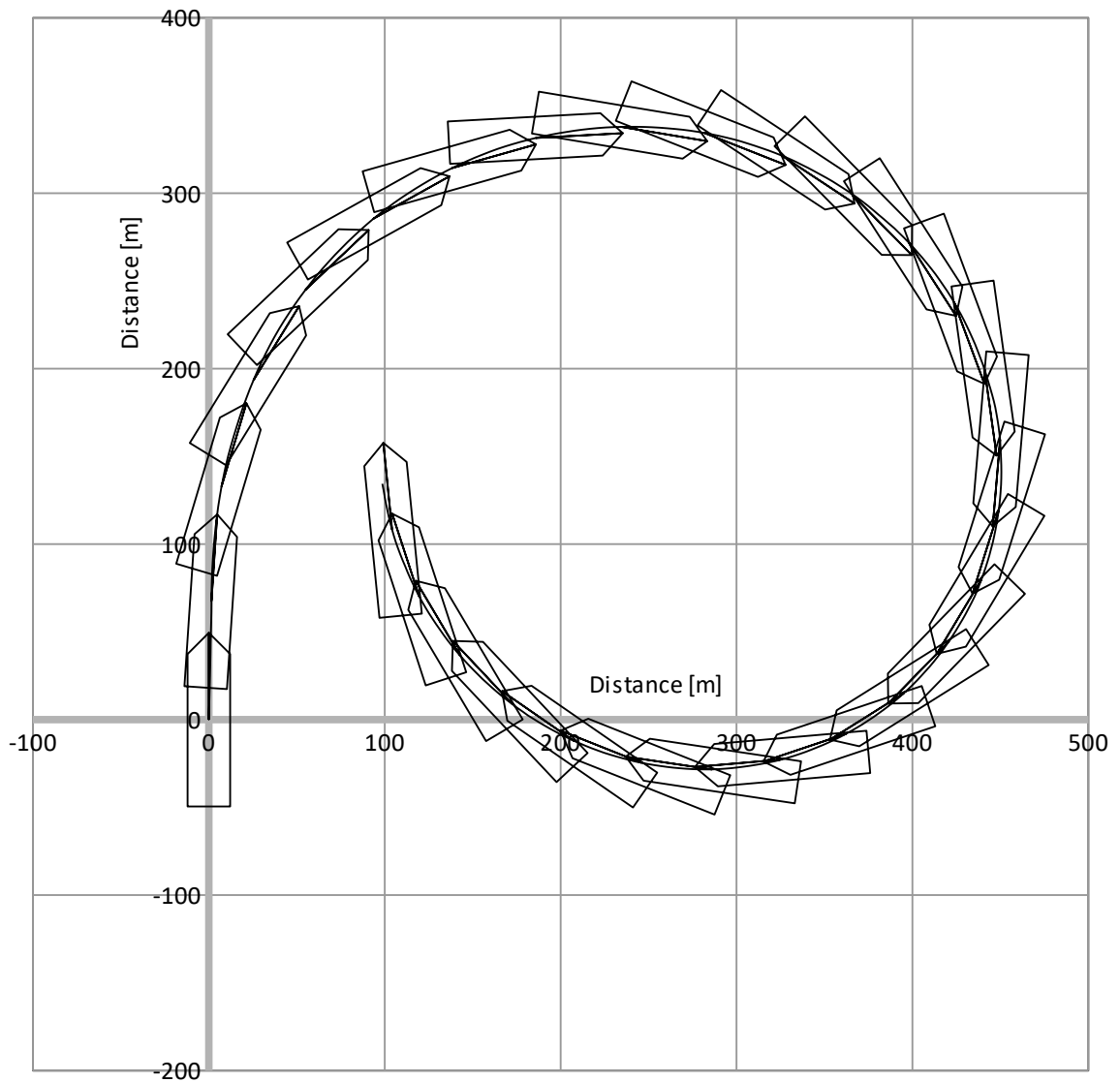

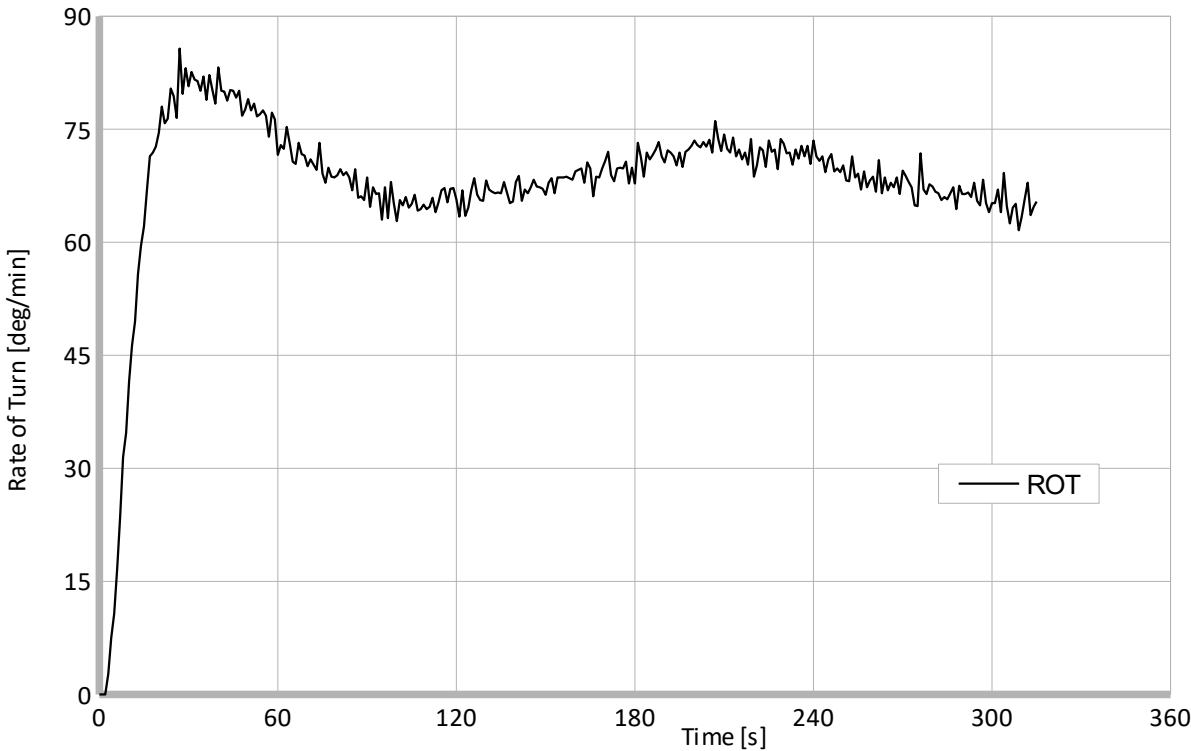
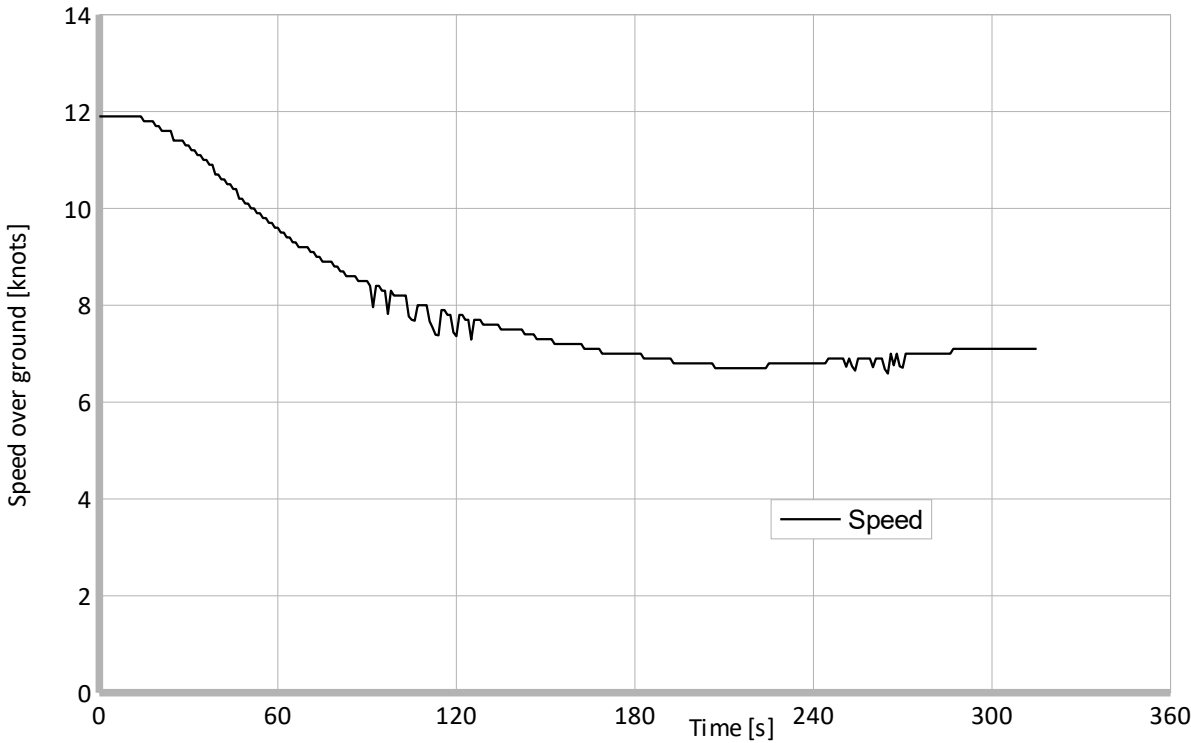

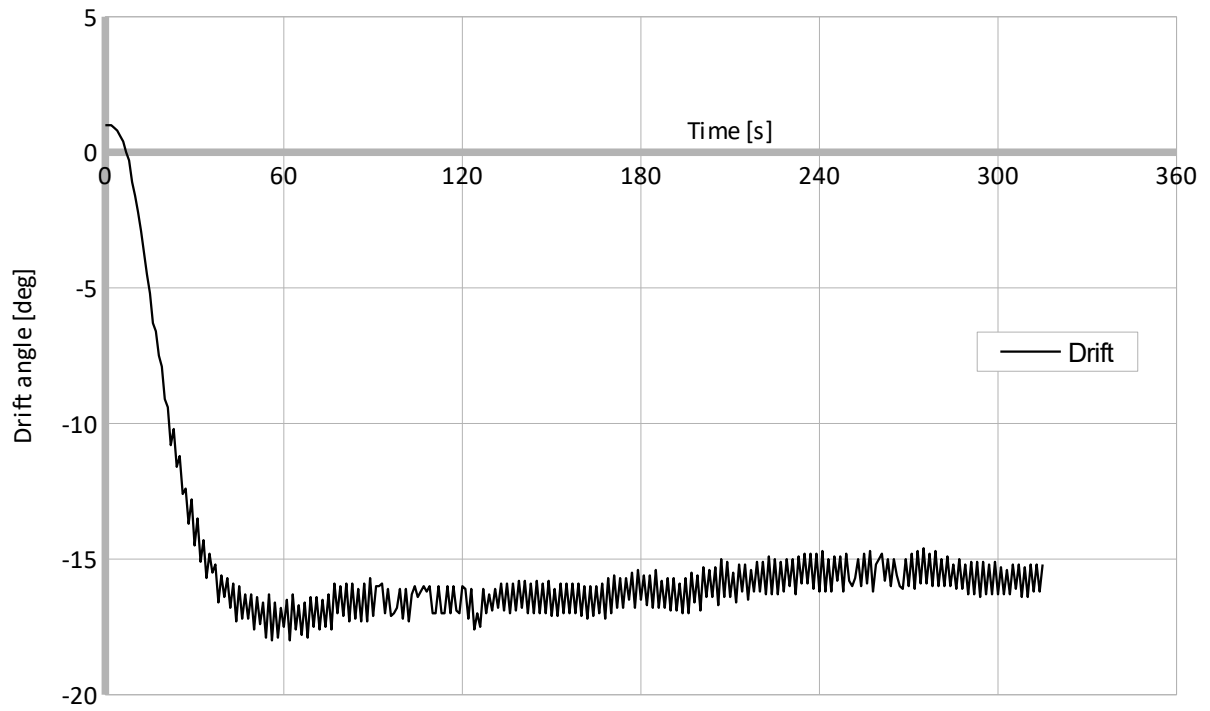

Pull out test stbd			
13.5.2014			
Wind direction [deg]	330	Initial heading [deg]	335
Wind speed [m/s]	6	Residual rudder angle [deg]	0
Initial rudder [deg] stbd	33	Residual turning rate [deg/s]	0,20
		[deg/min]	12
Initial speed [knots]	7,1		

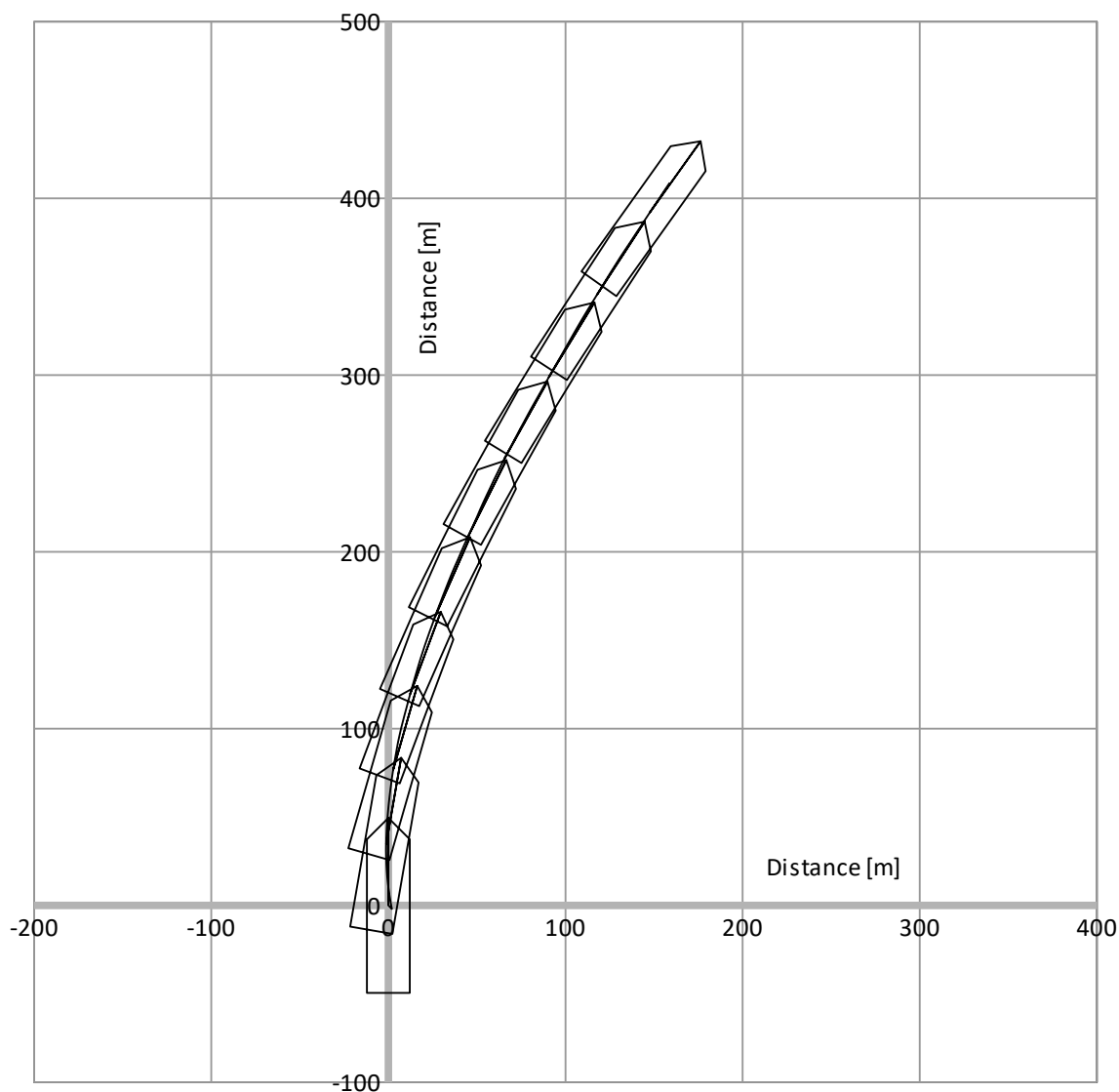

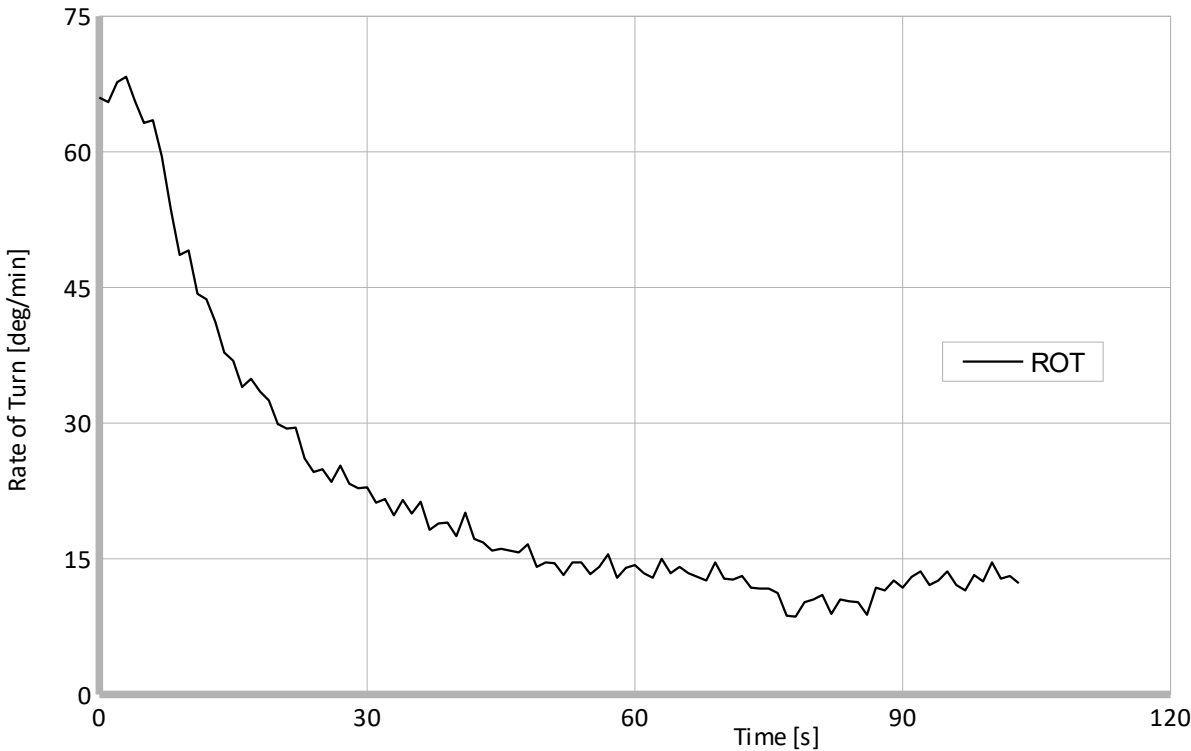
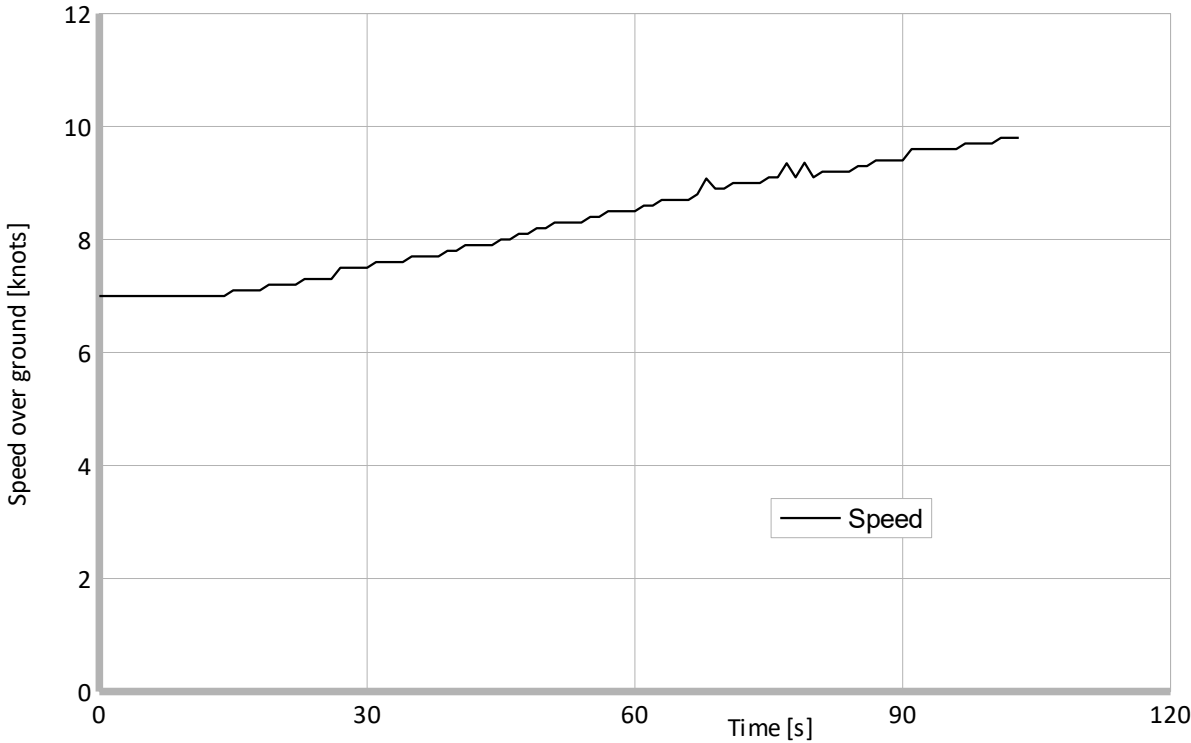

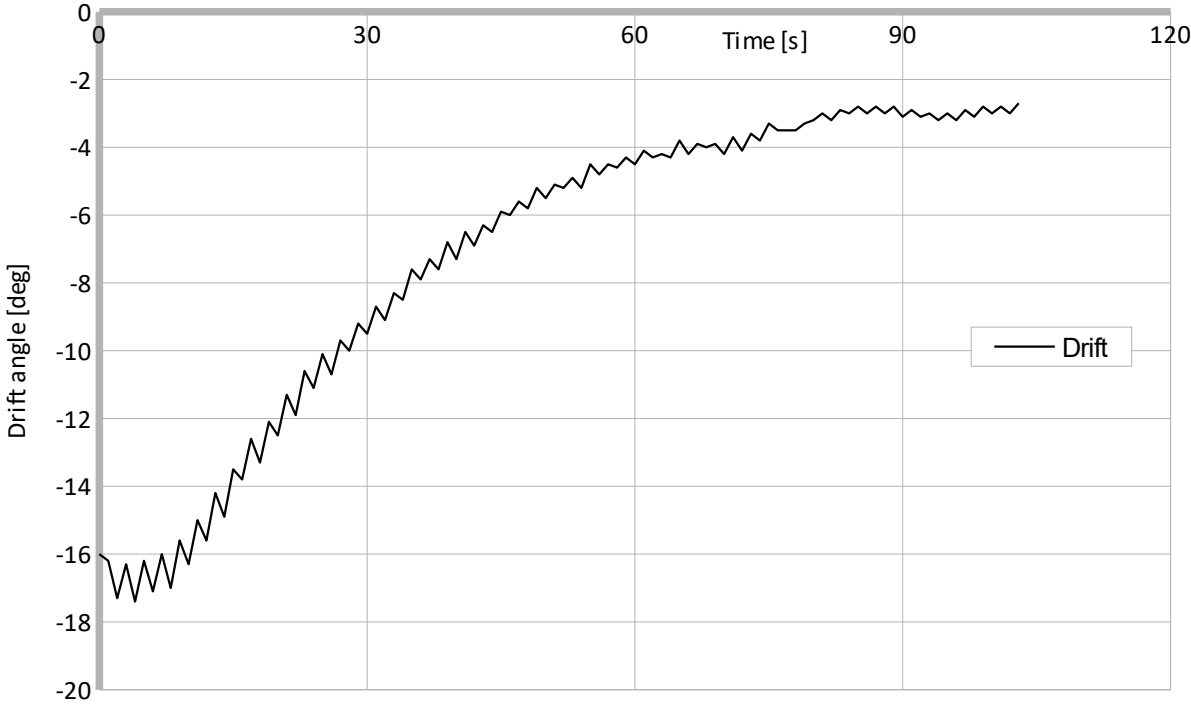

Pull out test port			
13.5.2014			
Wind direction [deg]	330	Initial heading [deg]	150
Wind speed [m/s]	6	Residual rudder angle [deg] stbd	1
Initial rudder [deg] port	34	Residual turning rate [deg/s]	0,10
		[deg/min]	6
Initial speed [knots]	7,3		

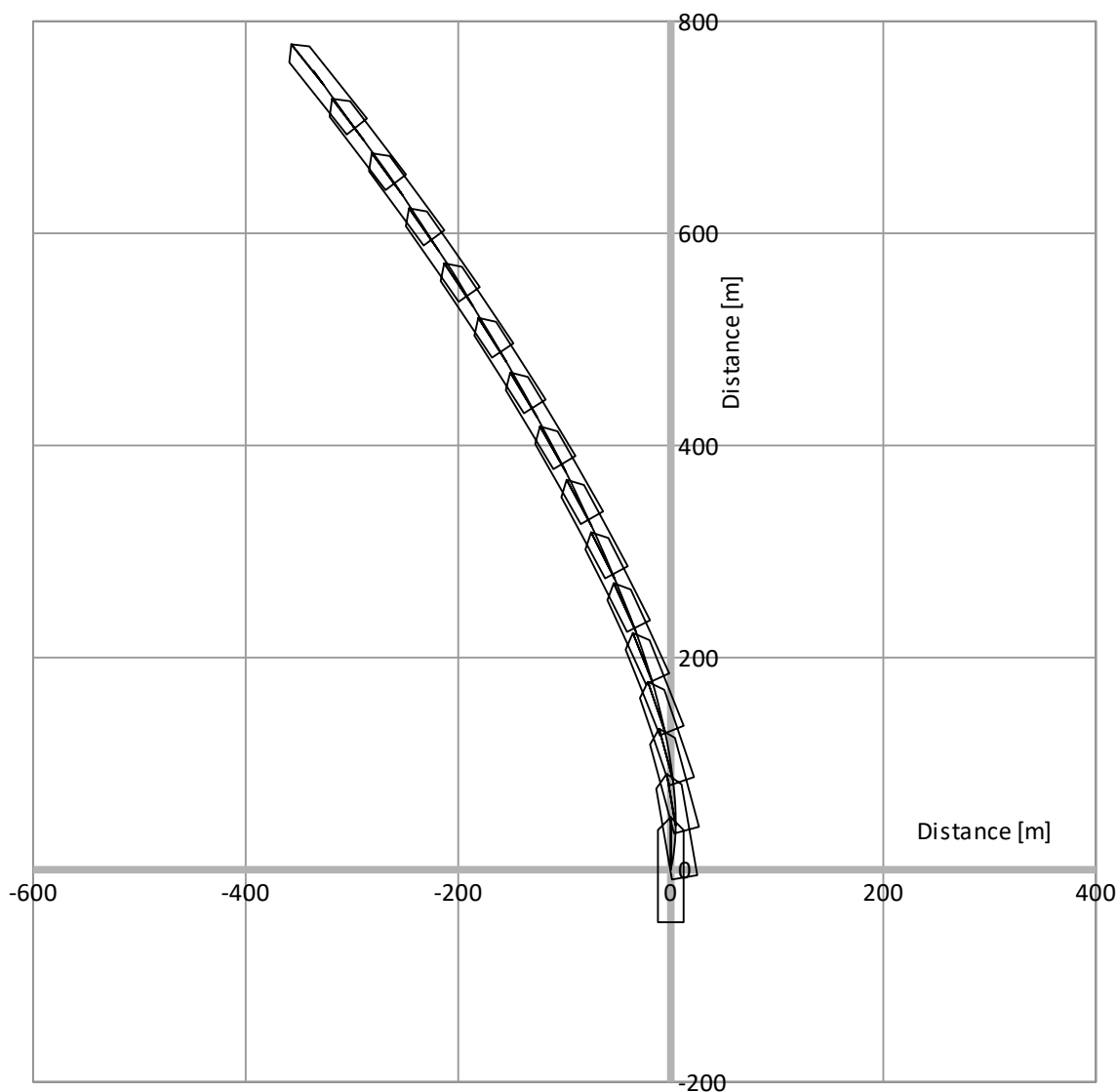

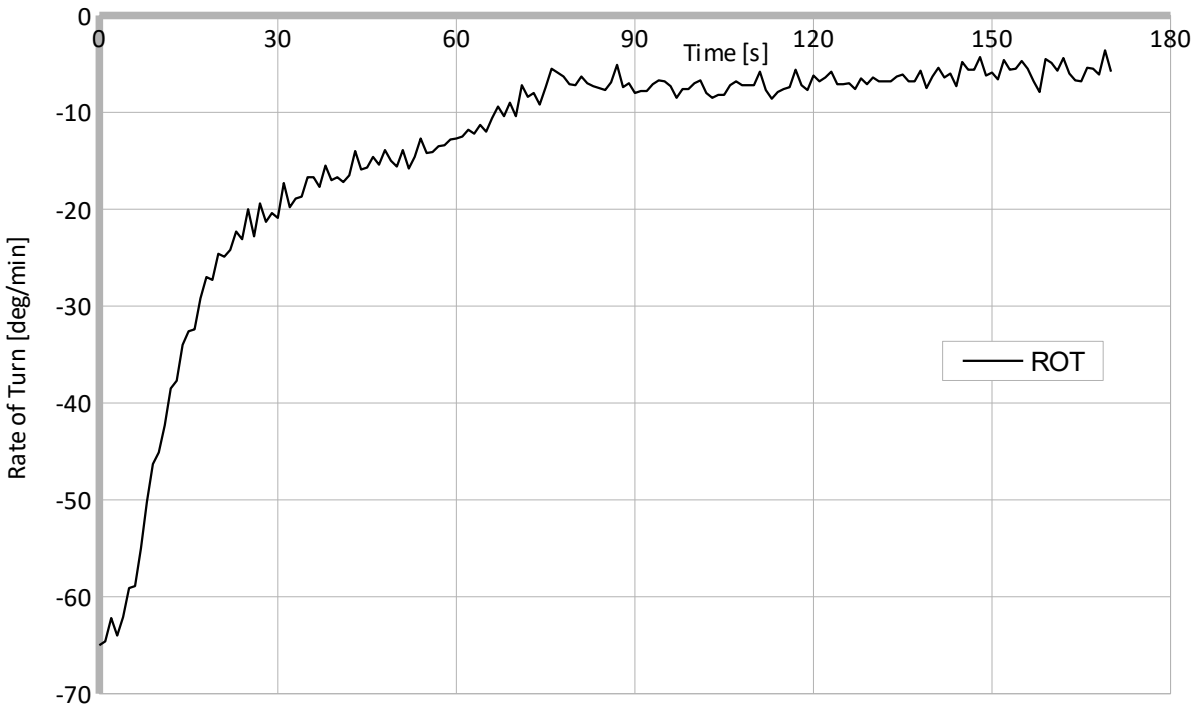
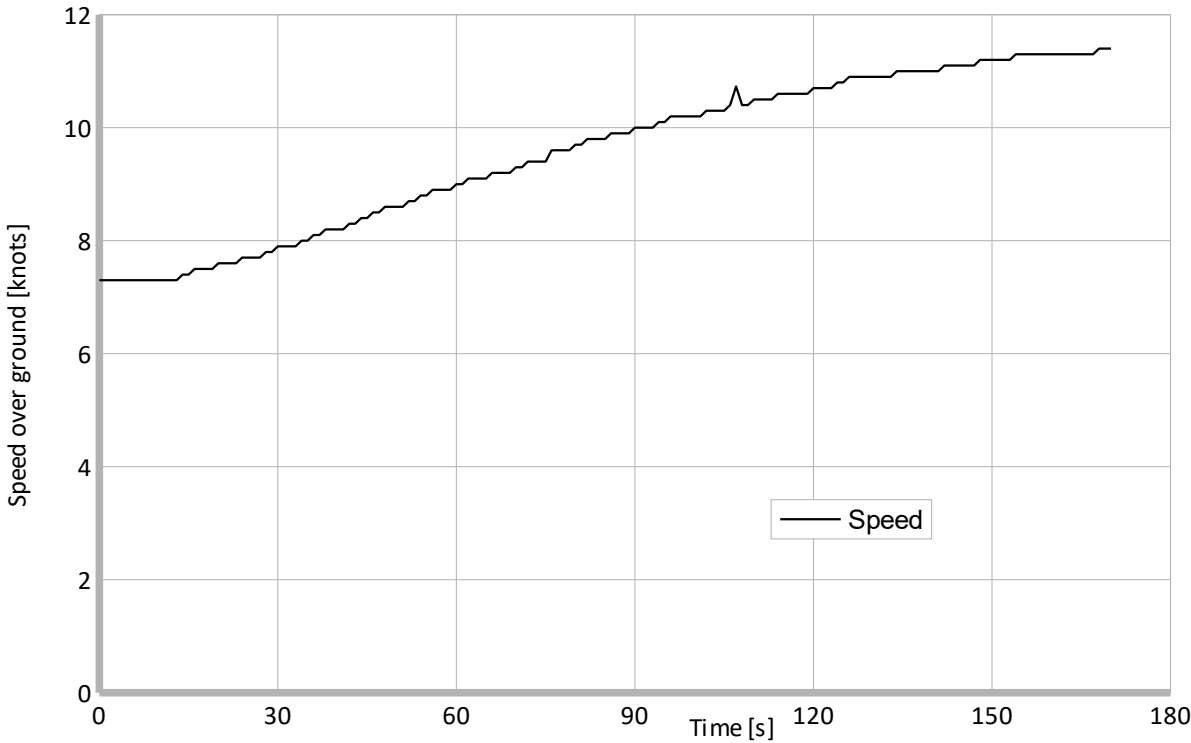

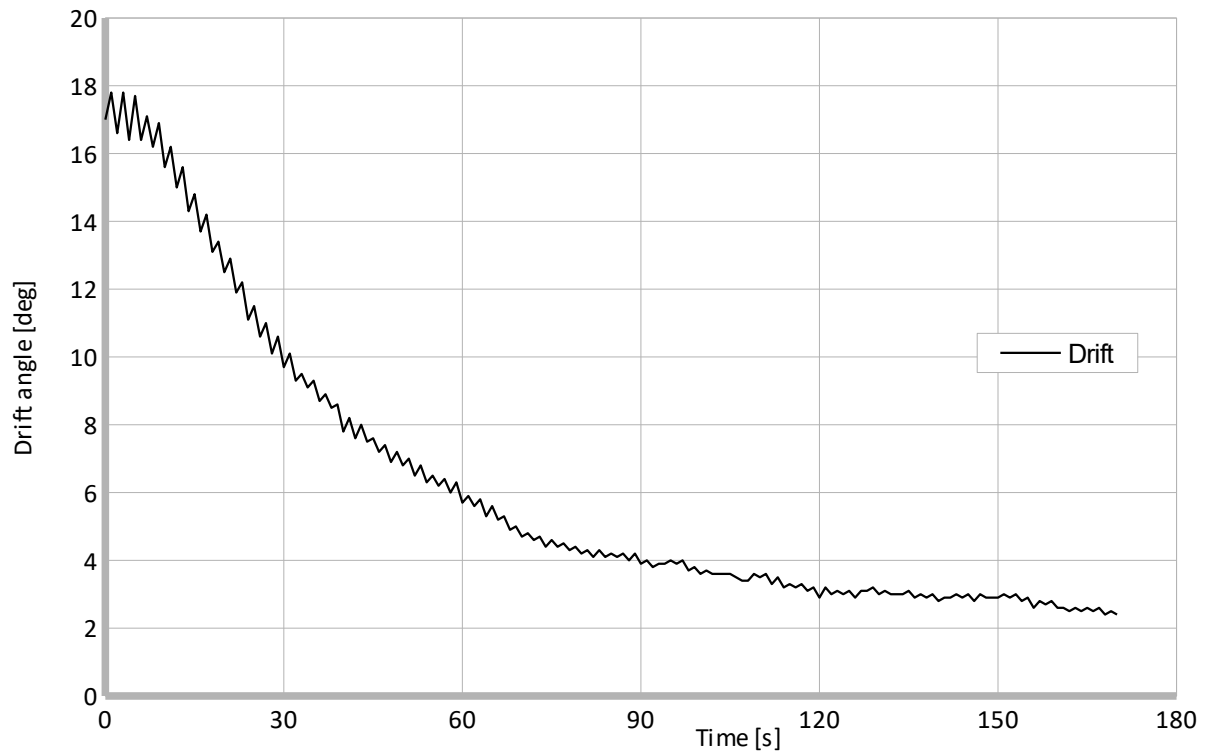

Pull out test stbd(2)			
13.5.2014			
Wind direction [deg]	330	Initial heading [deg]	150
Wind speed [m/s]	6	Residual rudder angle [deg] stbd	1
Initial rudder [deg] stbd	33	Residual turning rate [deg/s]	0,25
		[deg/min]	15
Initial speed [knots]	7,1		

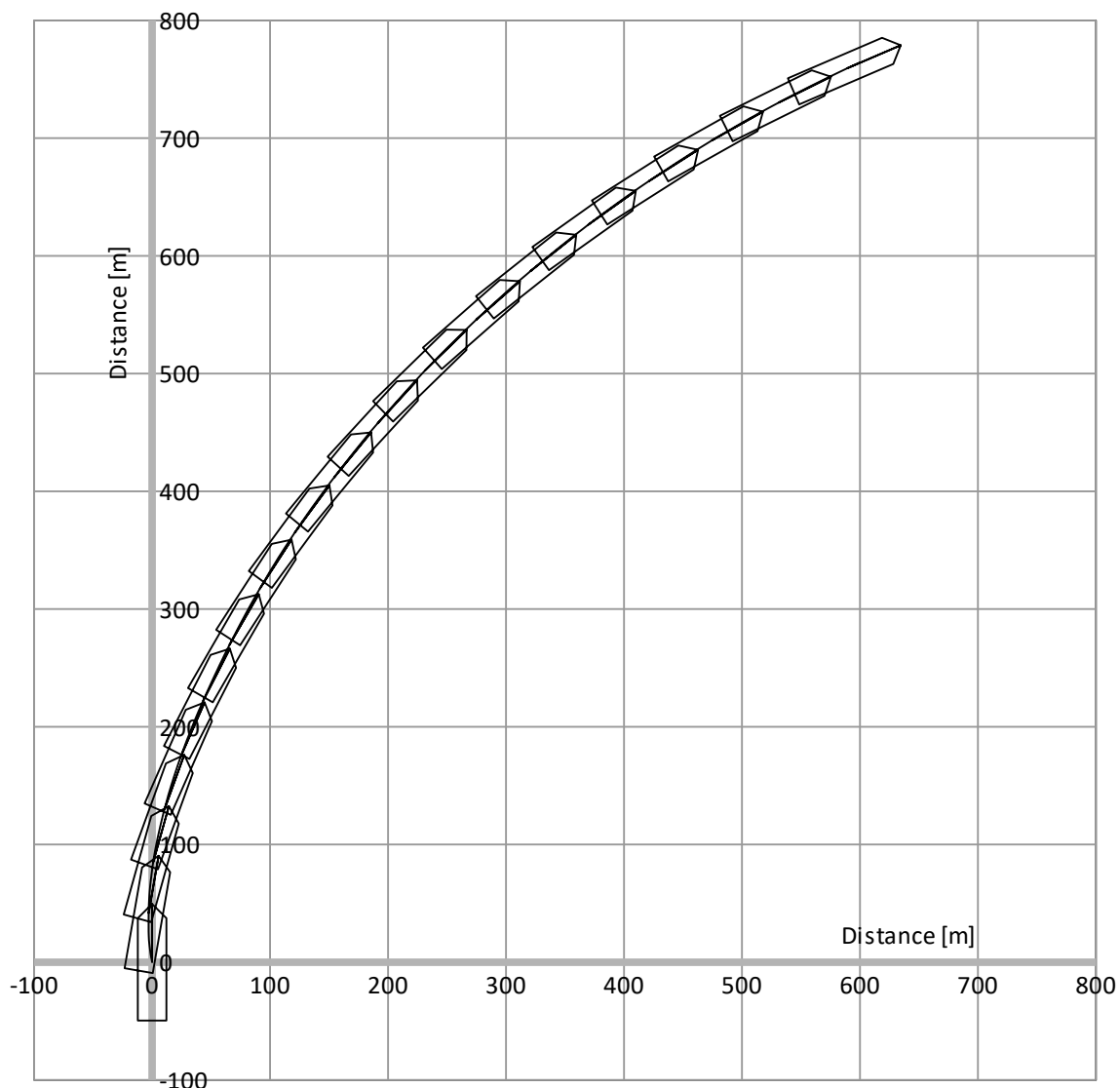

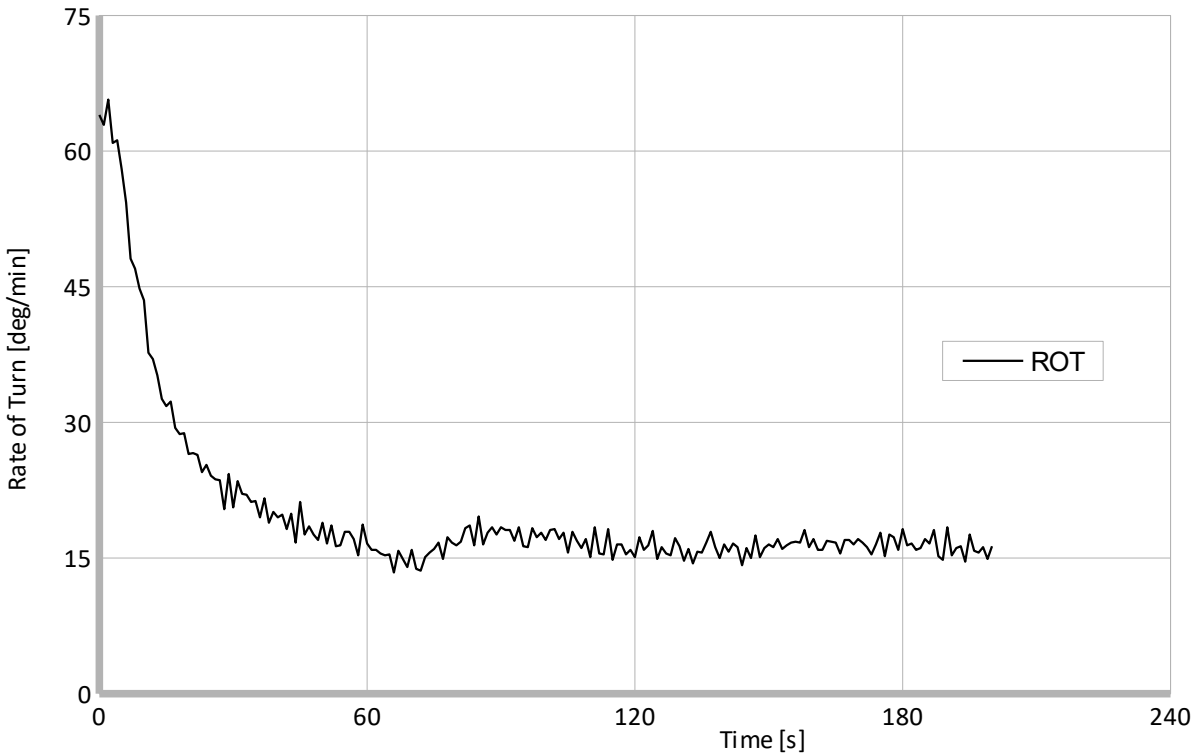
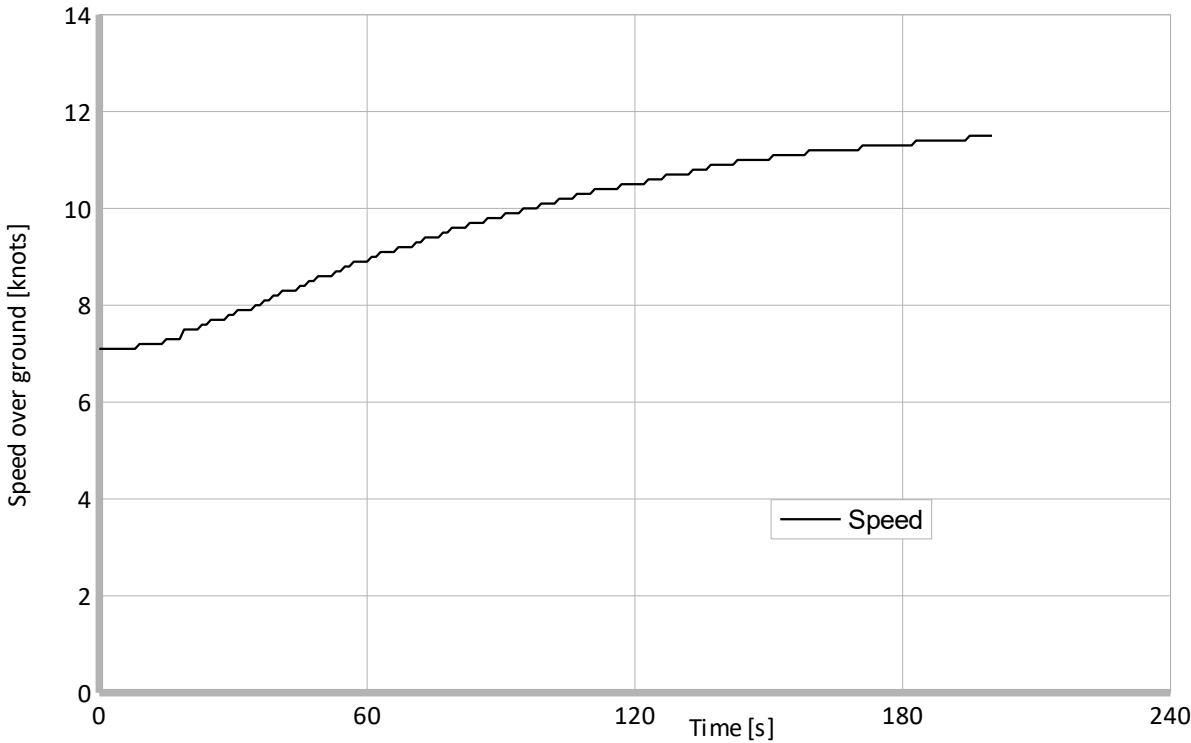

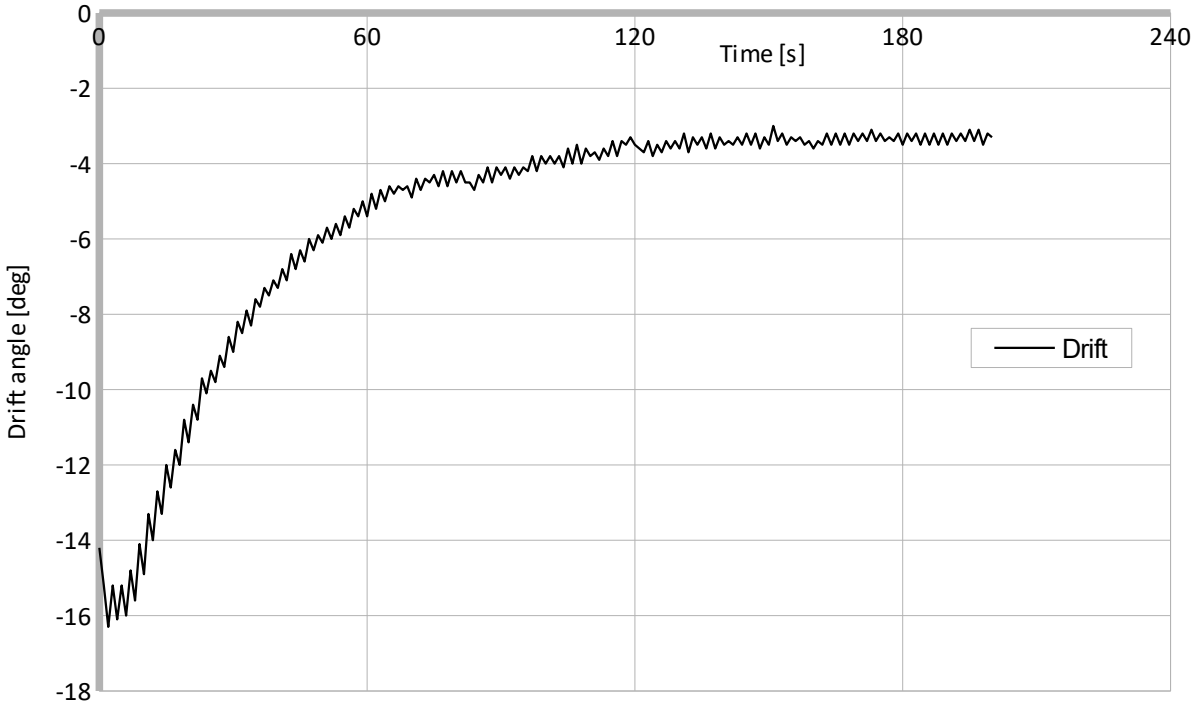

10 Z-test with bow thruster at 4 knots			
13.5.2014			
Wind direction [deg]	330	Time to check first yaw [s]	19
Wind speed [m/s]	6	First overshoot angle [deg]	7,1
		Time to check second yaw [s]	35
Initial speed [knots]	4,2	Second overshoot angle [deg]	15,6
Initial heading [deg]	323	Turning rate [deg/s]	0,76
		[deg/min]	46
Initial turning time [s]	36	Time for complete cycle [s]	219

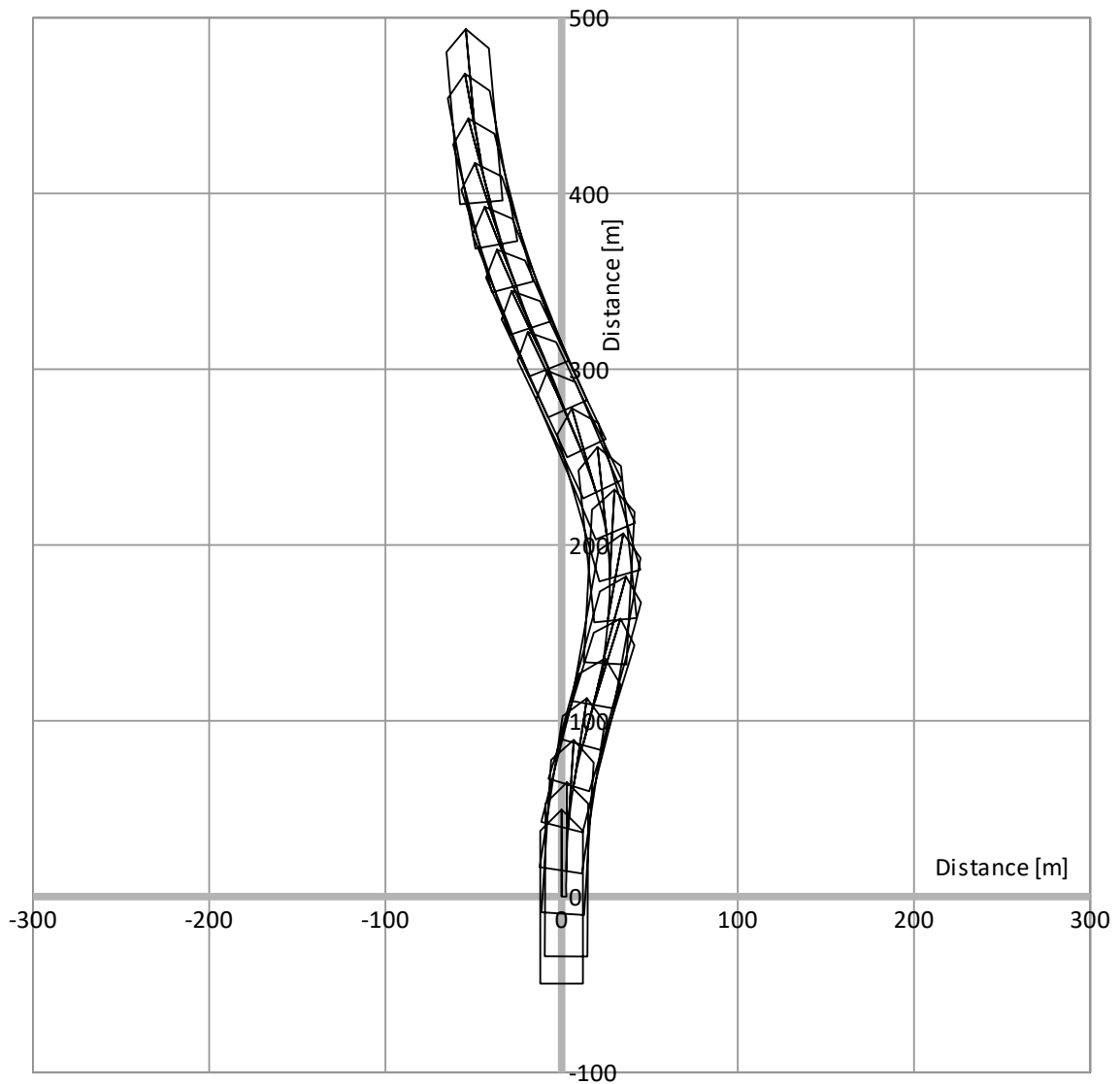

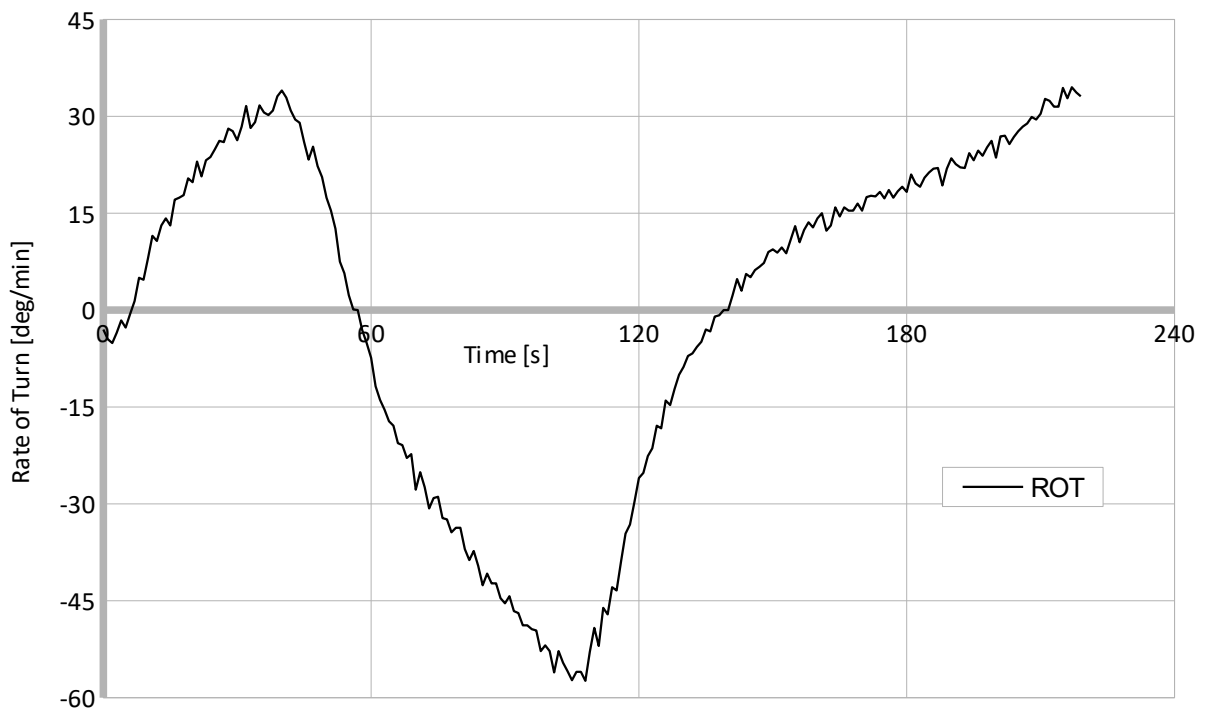
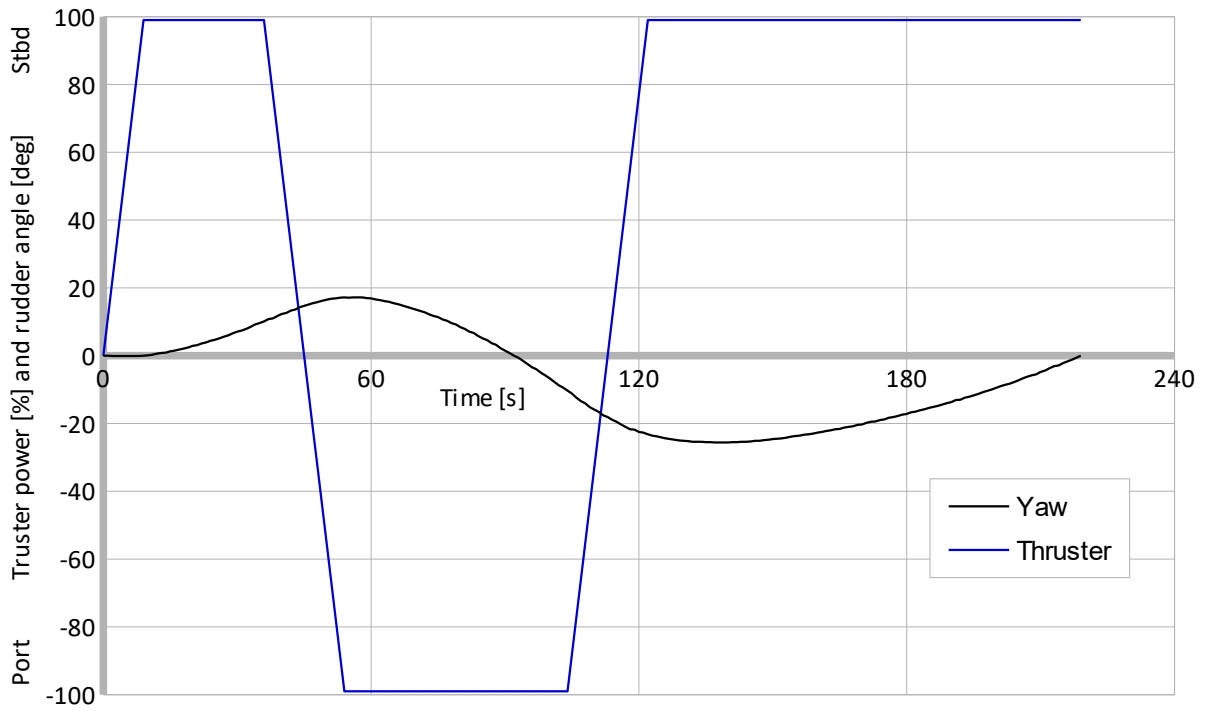

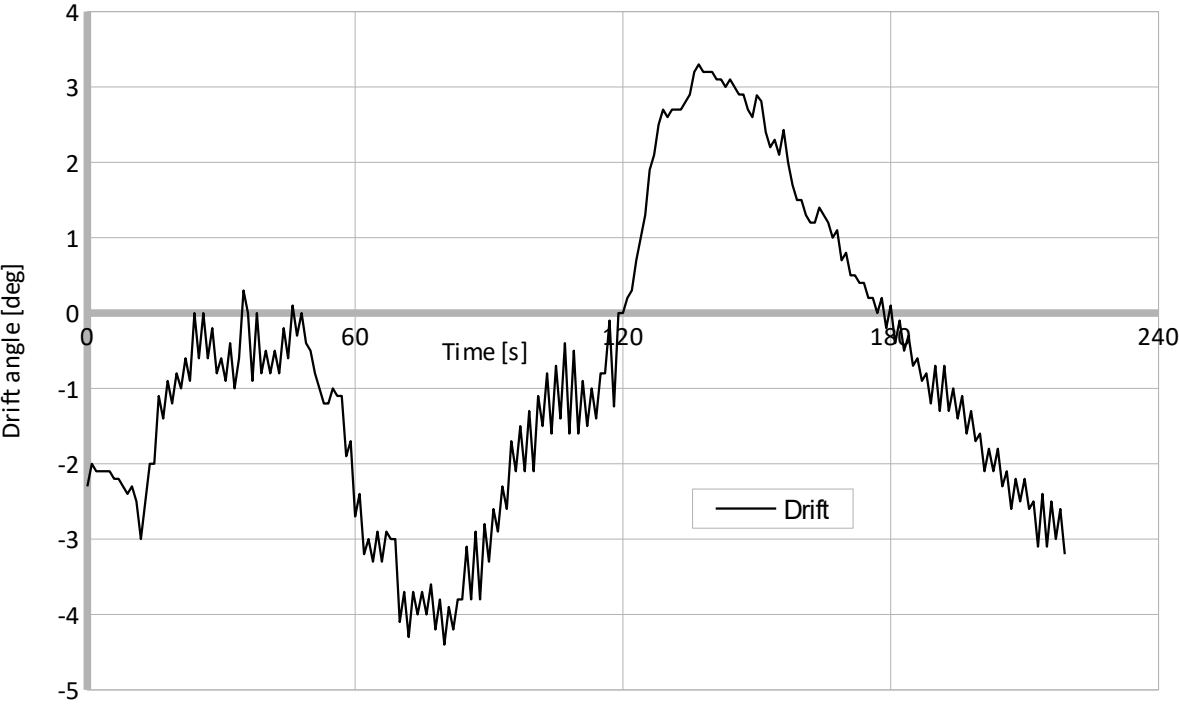
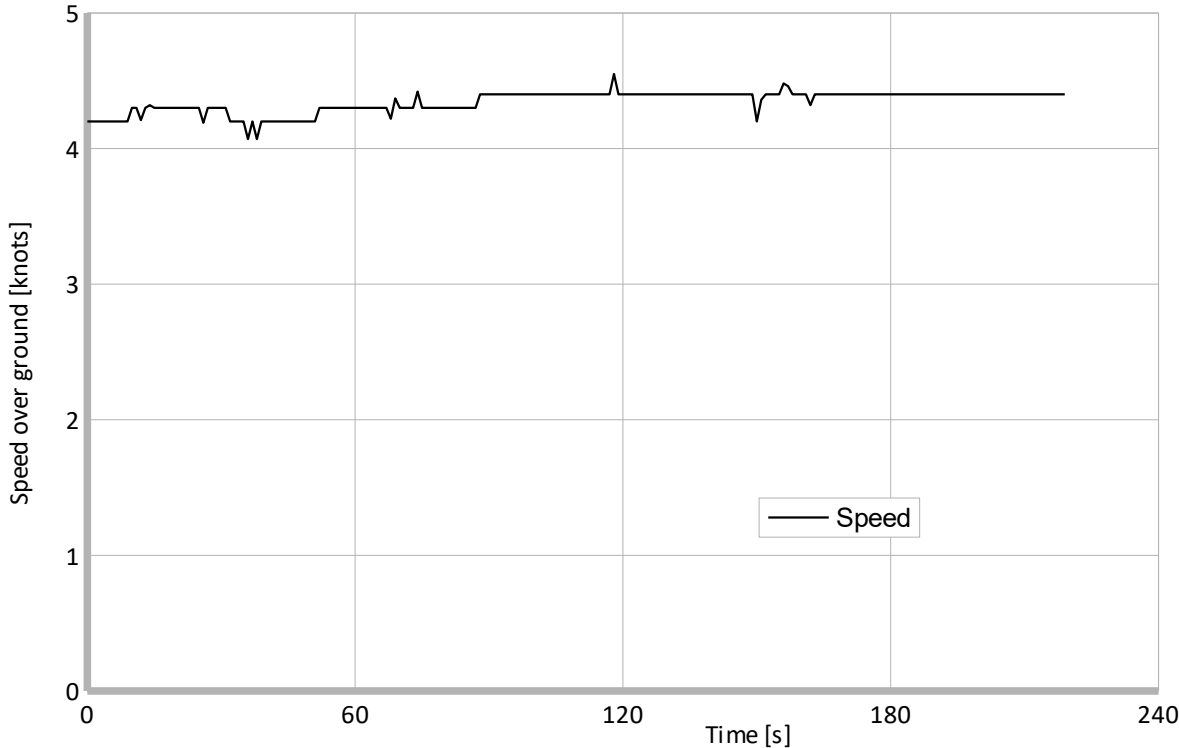

20 Z-test with bow thruster at zero speed

13.5.2014			
Wind direction [deg]	330	Time to check first yaw [s]	35
Wind speed [m/s]	6	First overshoot angle [deg]	28,2
		Time to check second yaw [s]	47
Initial speed [knots]	0,2	Second overshoot angle [deg]	41,8
Initial heading [deg]	322	Turning rate [deg/s]	1,58
		[deg/min]	95
Initial turning time [s]	38	Time for complete cycle [s]	255

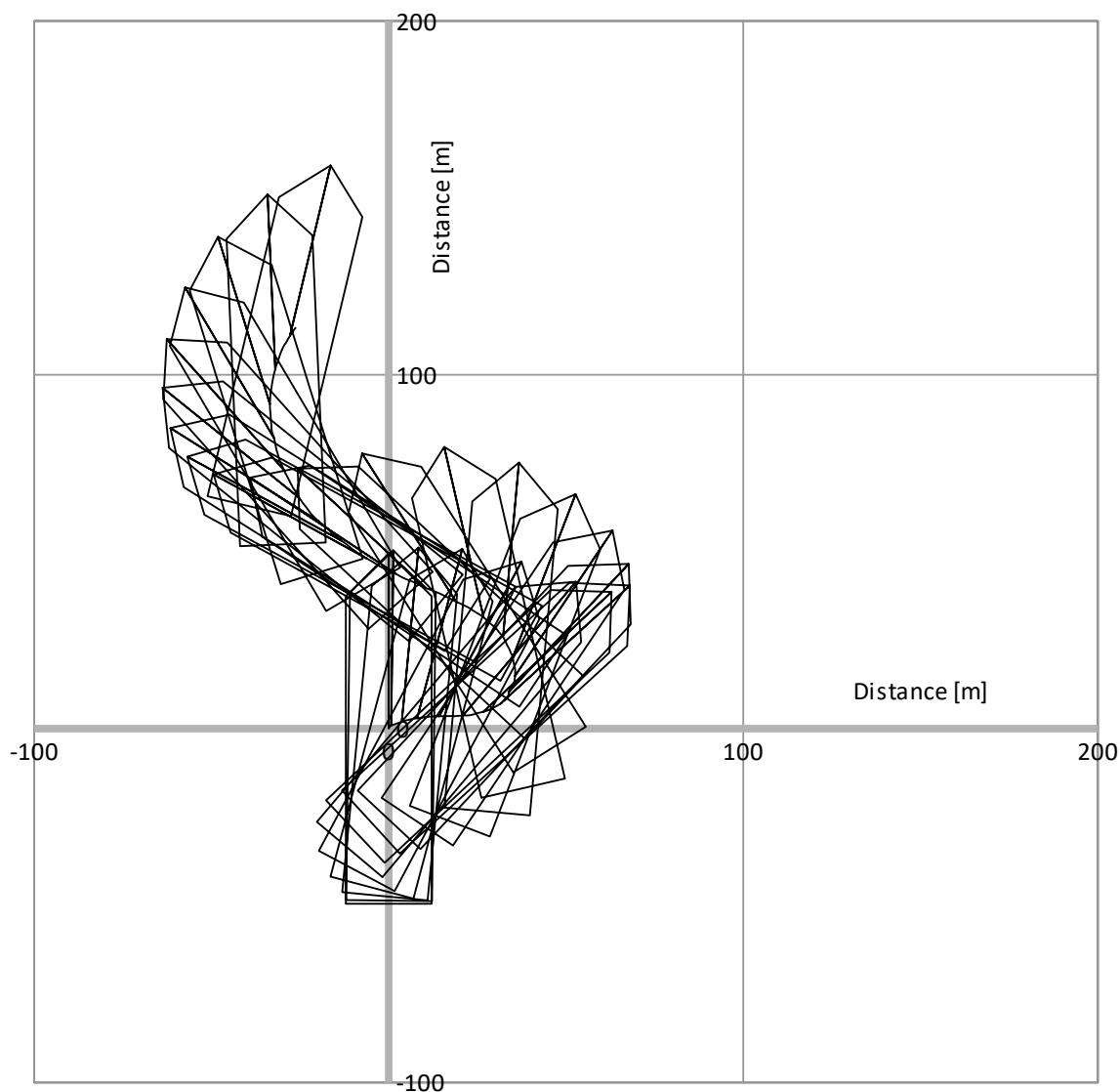

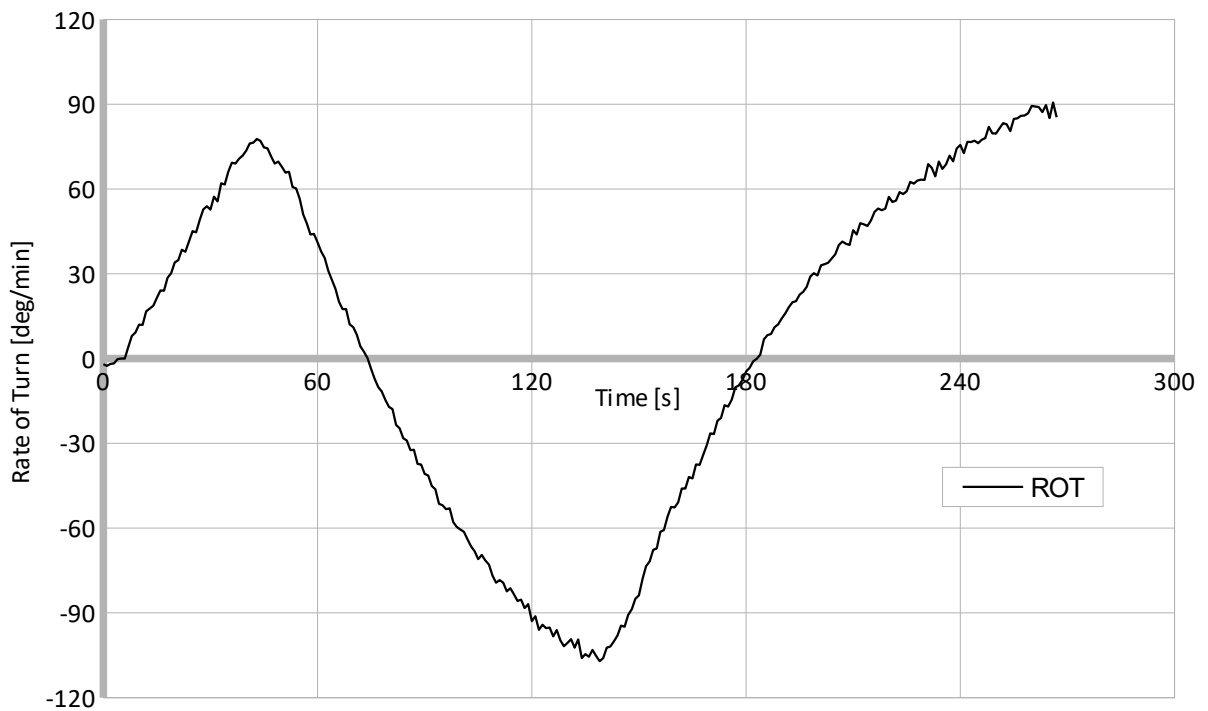
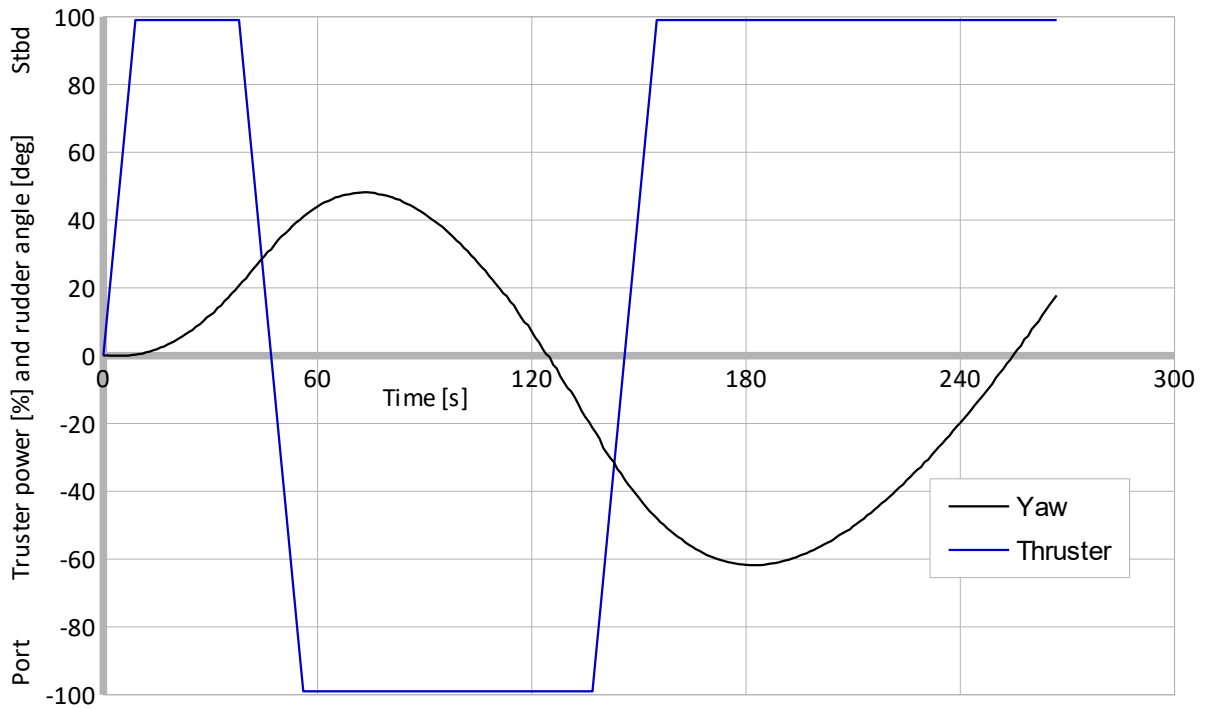

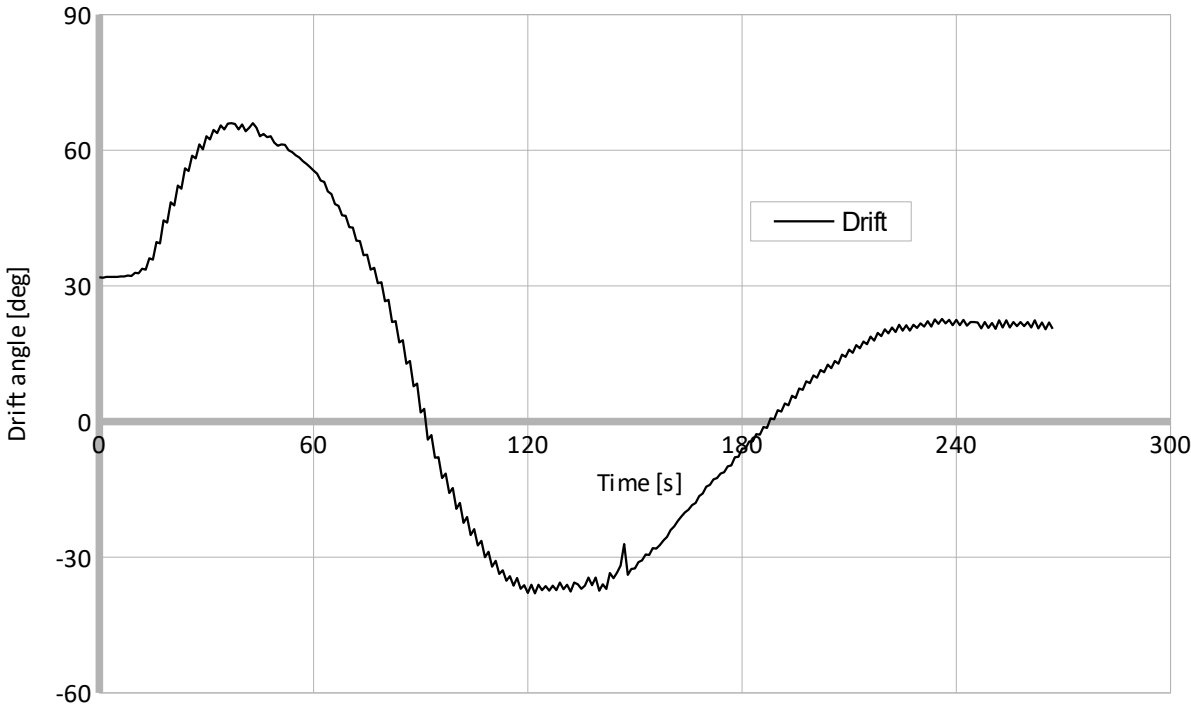
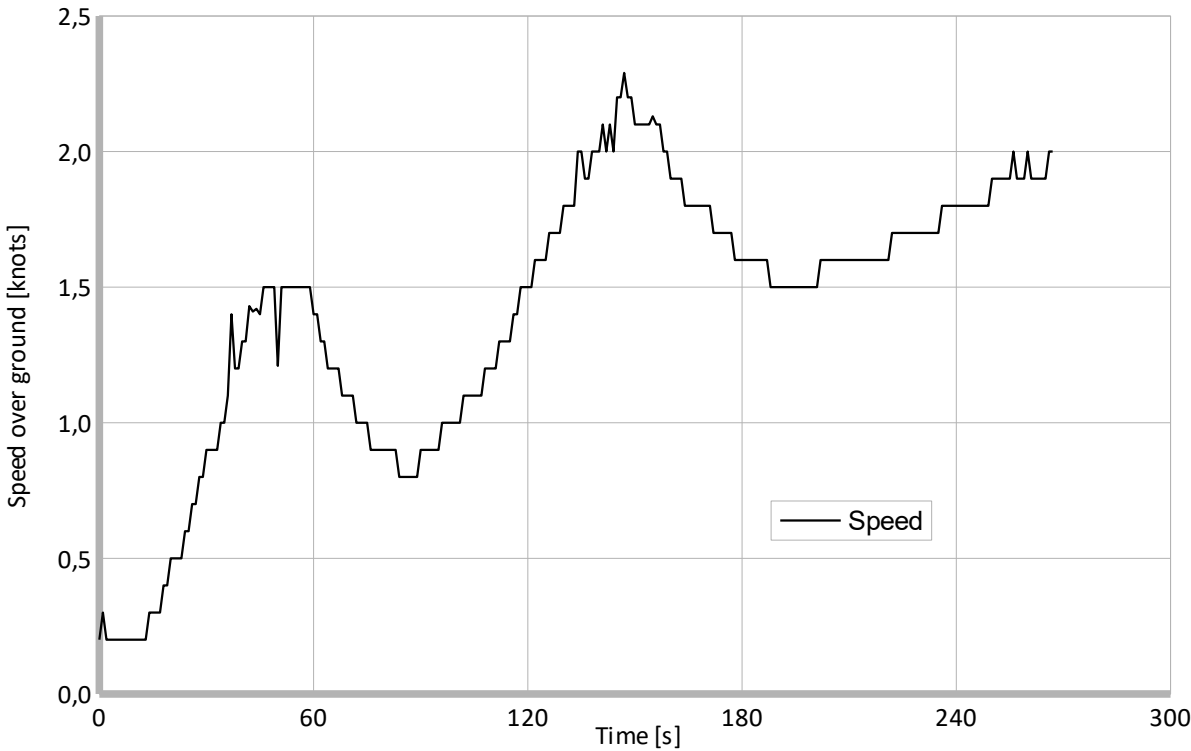

10 Z-test with bow thruster at 3 knots astern			
13.5.2014			
Wind direction [deg]	330	Time to check first yaw [s]	60
Wind speed [m/s]	6	First overshoot angle [deg]	50
		Time to check second yaw [s]	59
Initial speed [knots]	2,9	Second overshoot angle [deg]	59,1
Initial heading [deg]	322	Turning rate [deg/s]	1,75
		[deg/min]	105
Initial turning time [s]	25	Time for complete cycle [s]	276

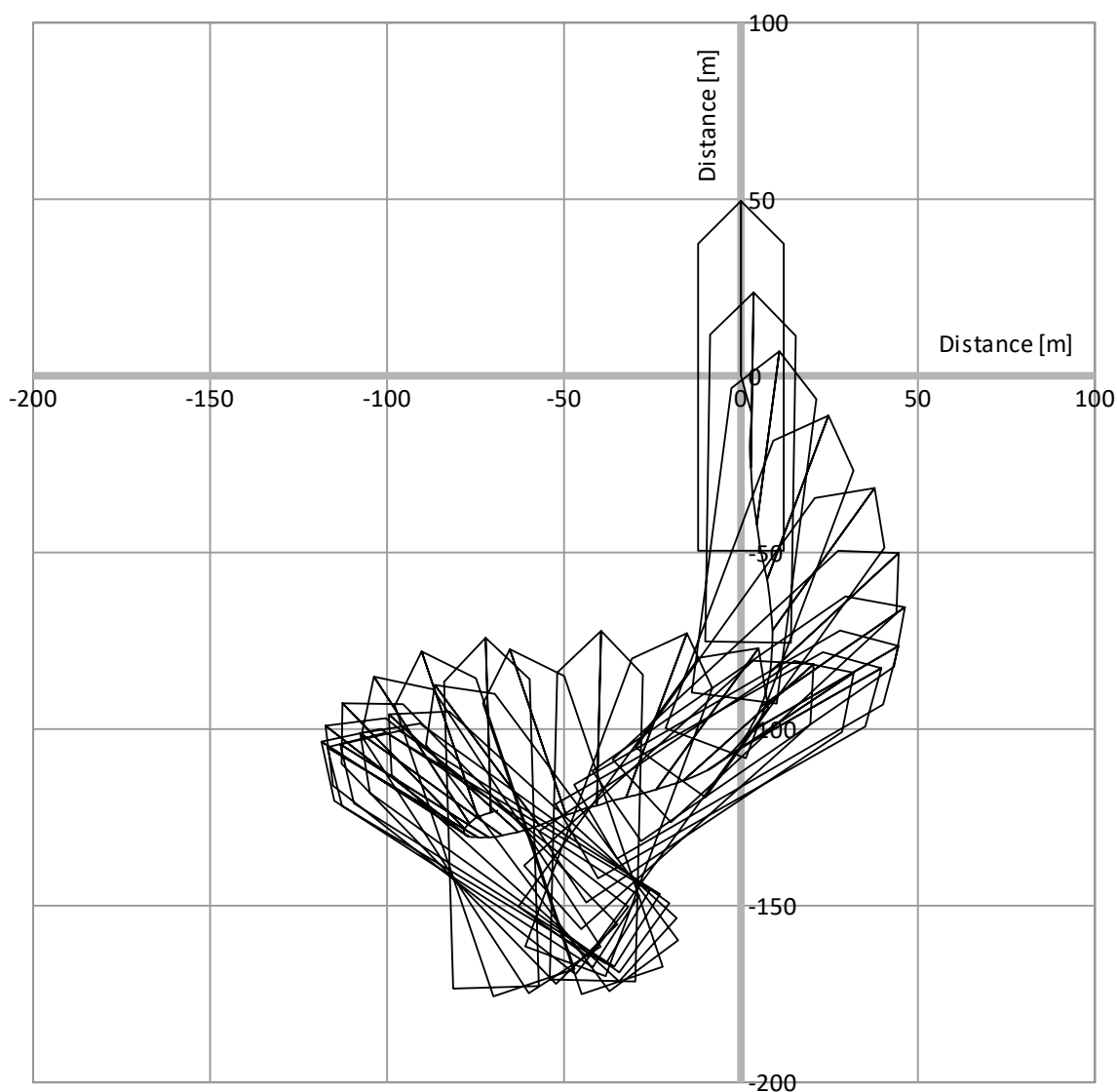

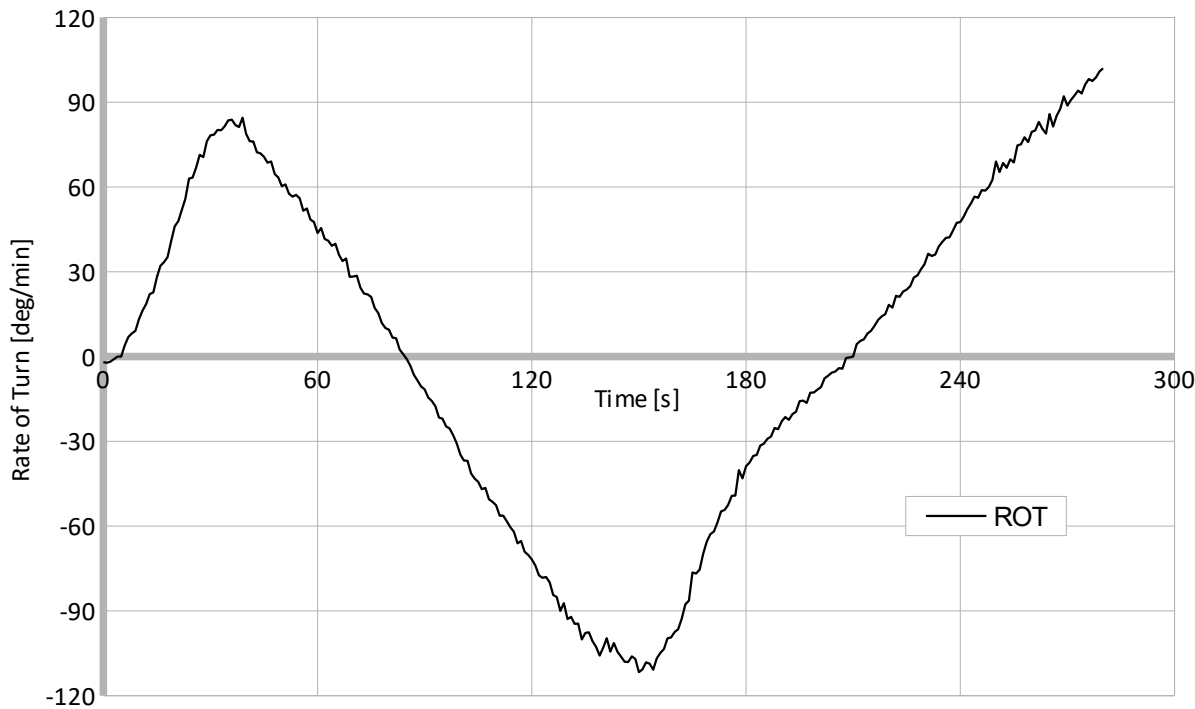
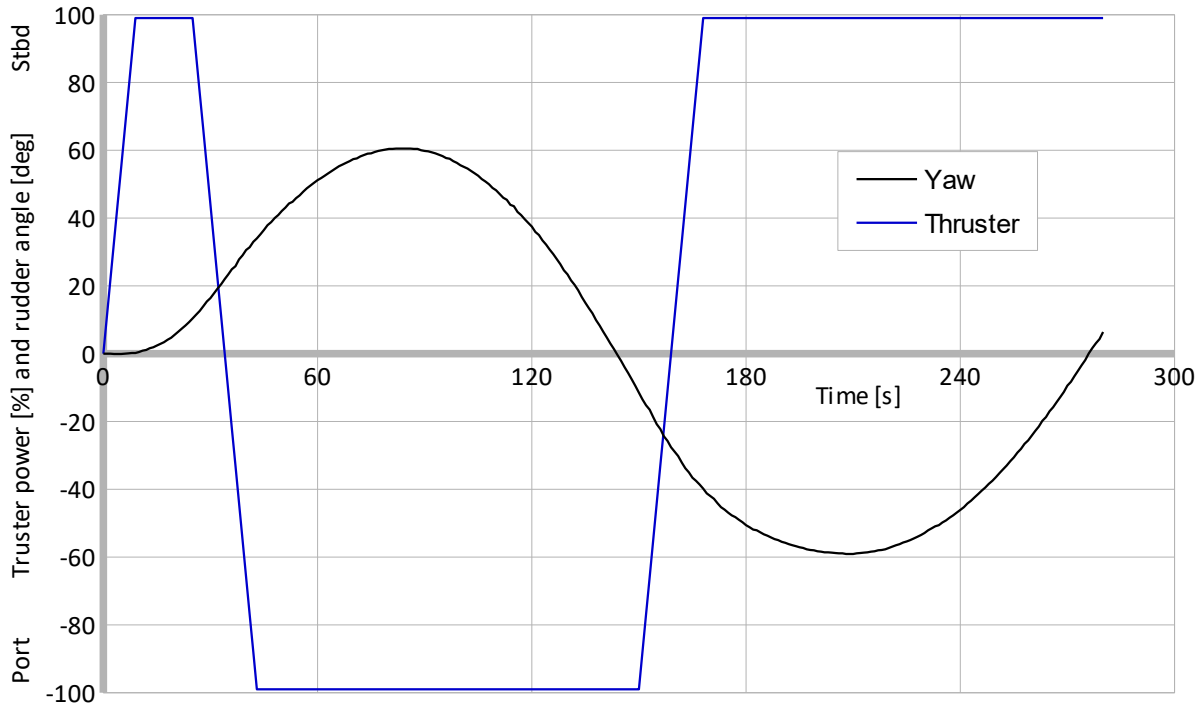

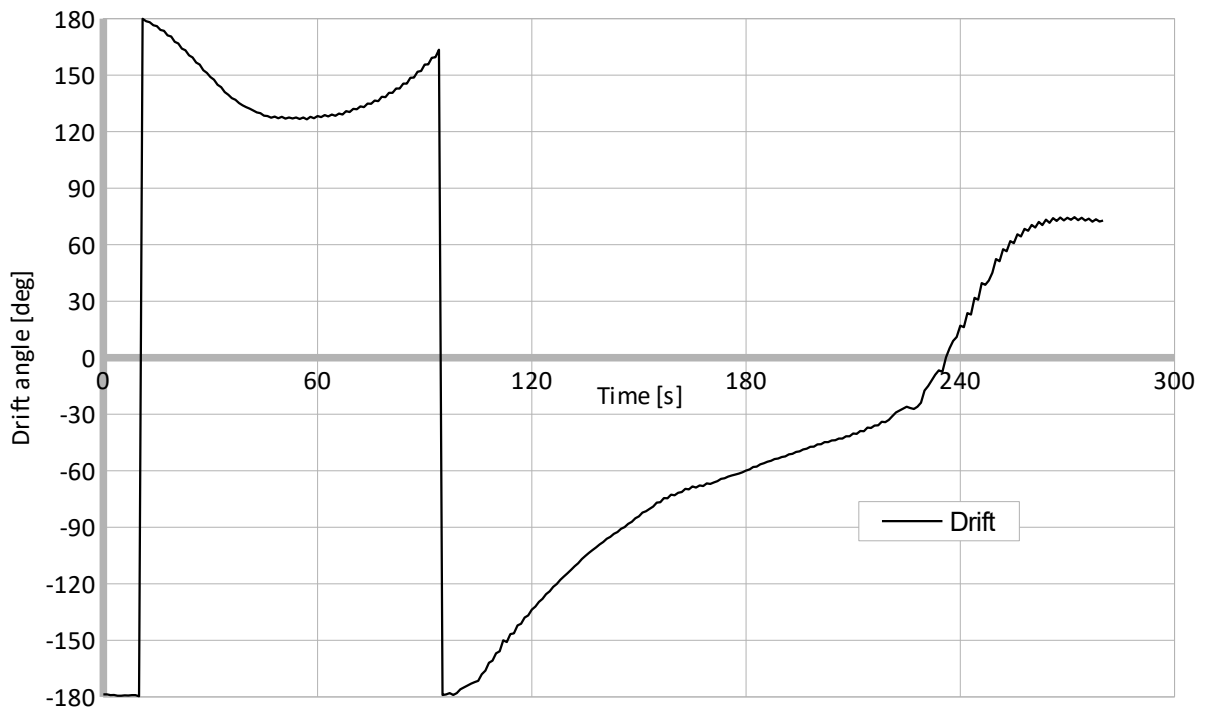
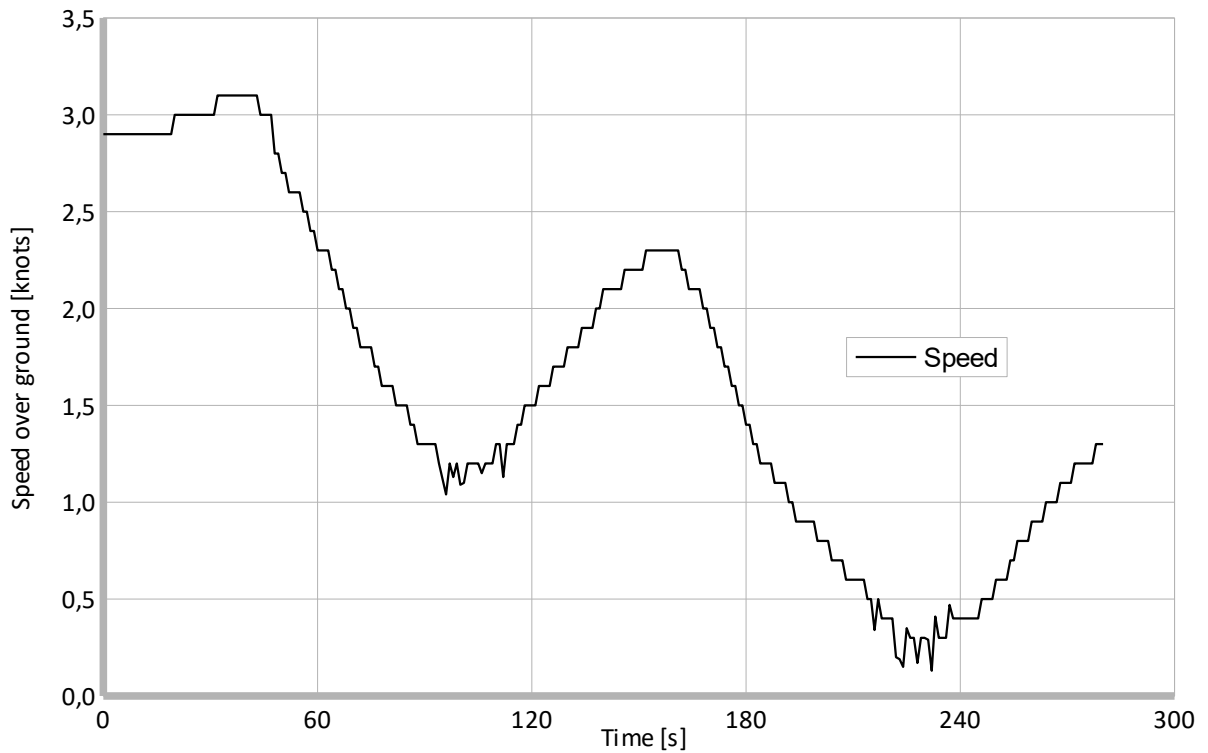

5 Z-test with bow thruster at 4 knots astern

13.5.2014

Wind direction [deg]	330	Time to check first yaw [s]	74
Wind speed [m/s]	6	First overshoot angle [deg]	51,9
		Time to check second yaw [s]	N/A
Initial speed [knots]	4	Second overshoot angle [deg]	N/A
Initial heading [deg]	320	Turning rate [deg/s]	N/A
		[deg/min]	N/A
Initial turning time [s]	16	Time for complete cycle [s]	N/A

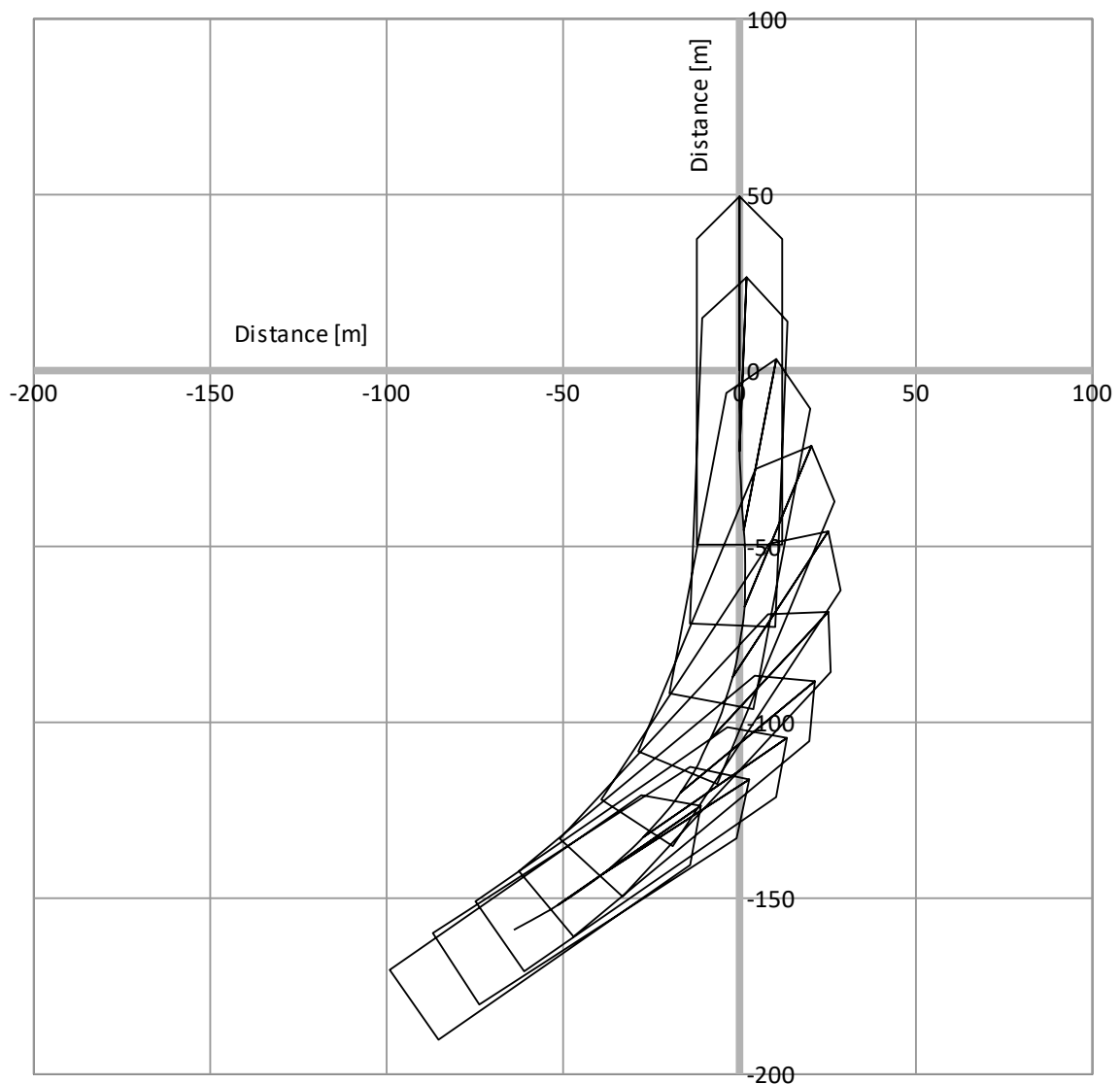

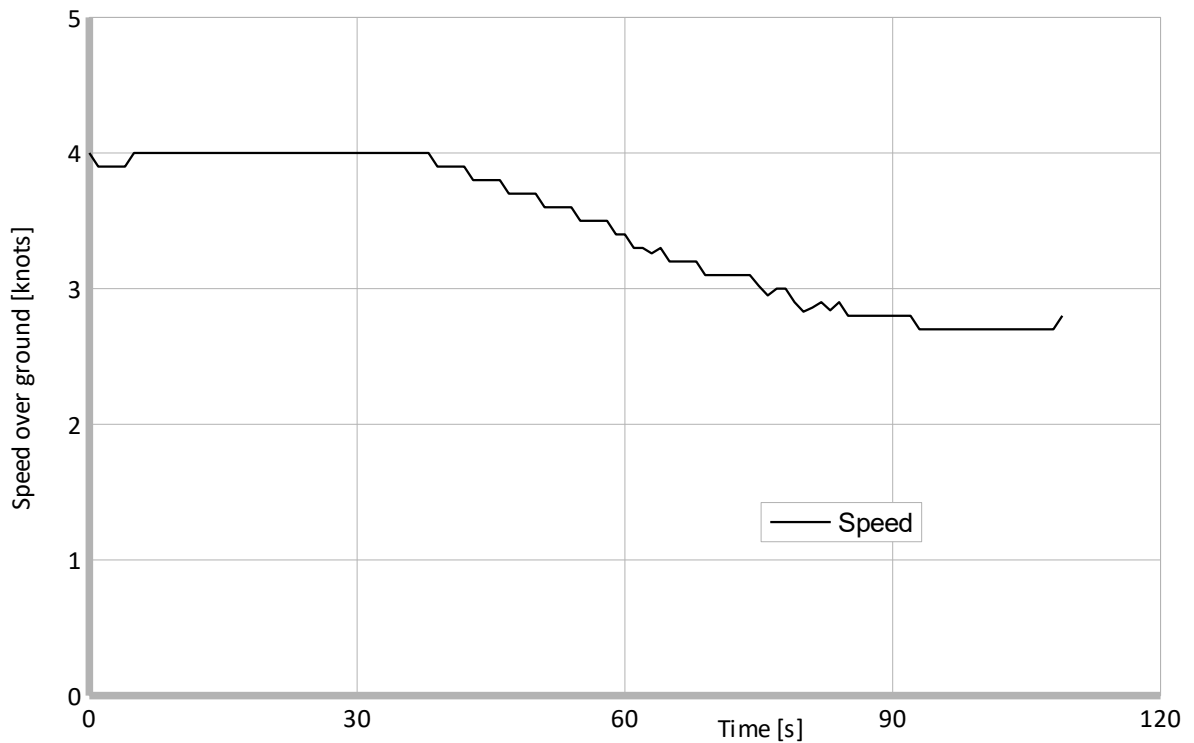
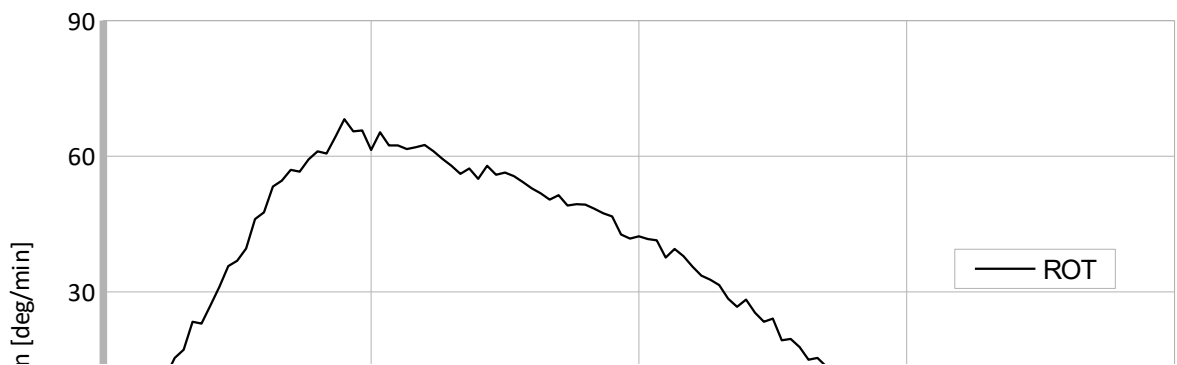
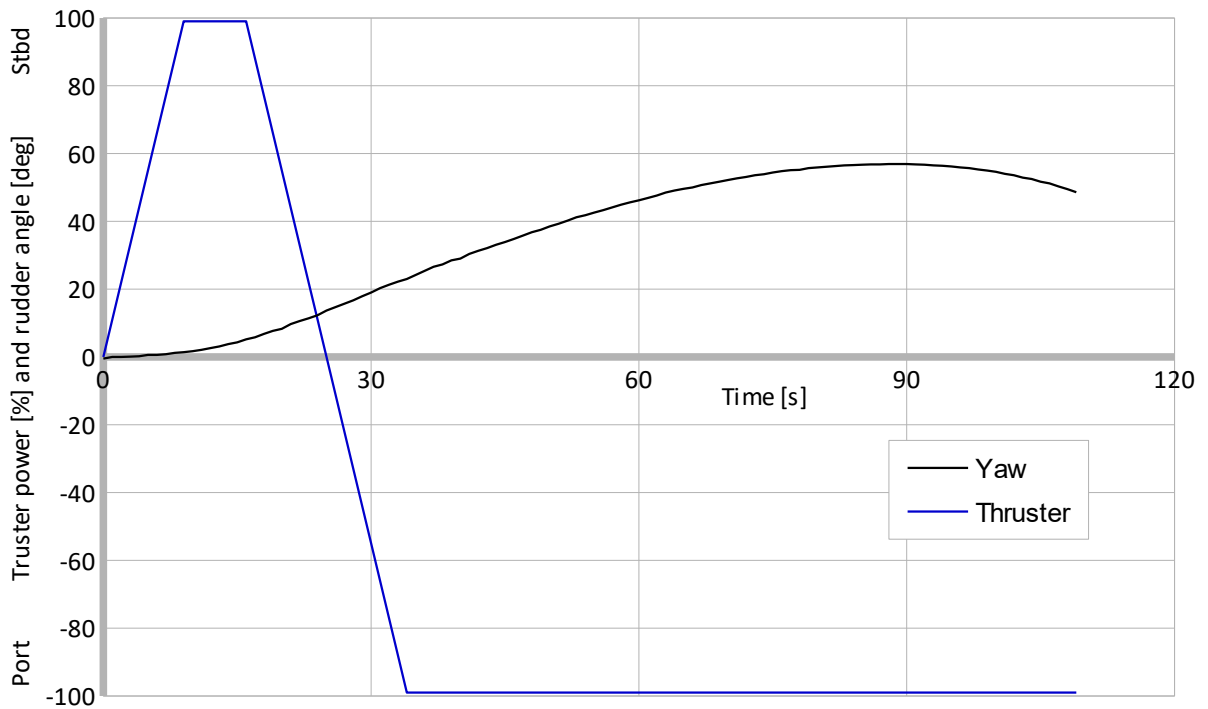

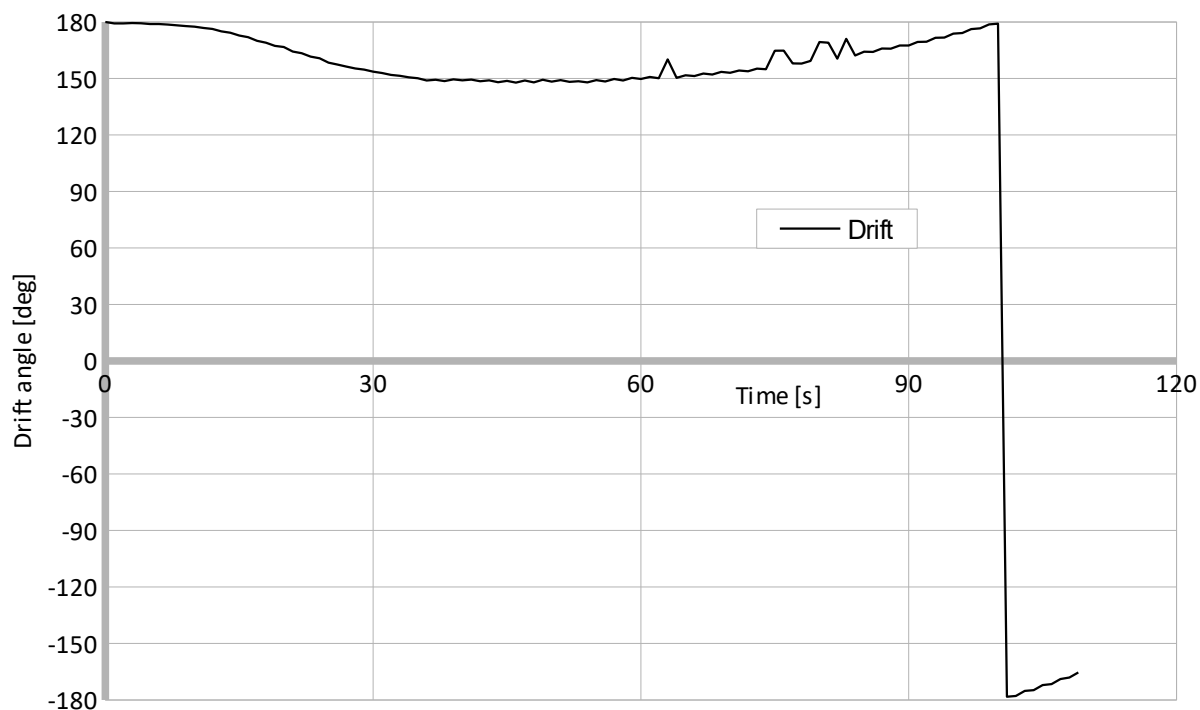

Astern test			
13.5.2014			
Wind direction [deg]	330	Initial speed [knots]	4,4
Wind speed [m/s]	6	Initial heading [deg]	319

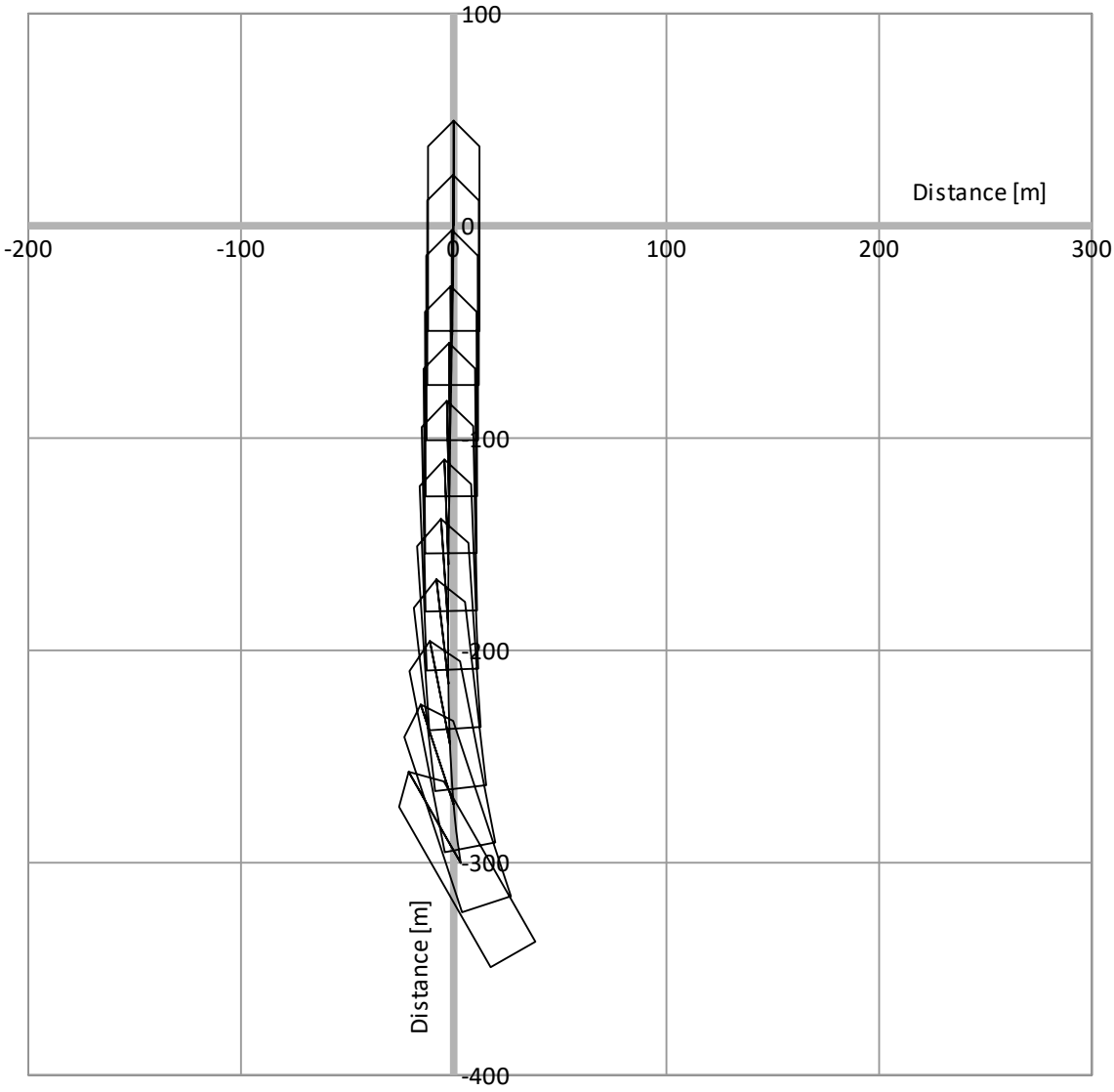

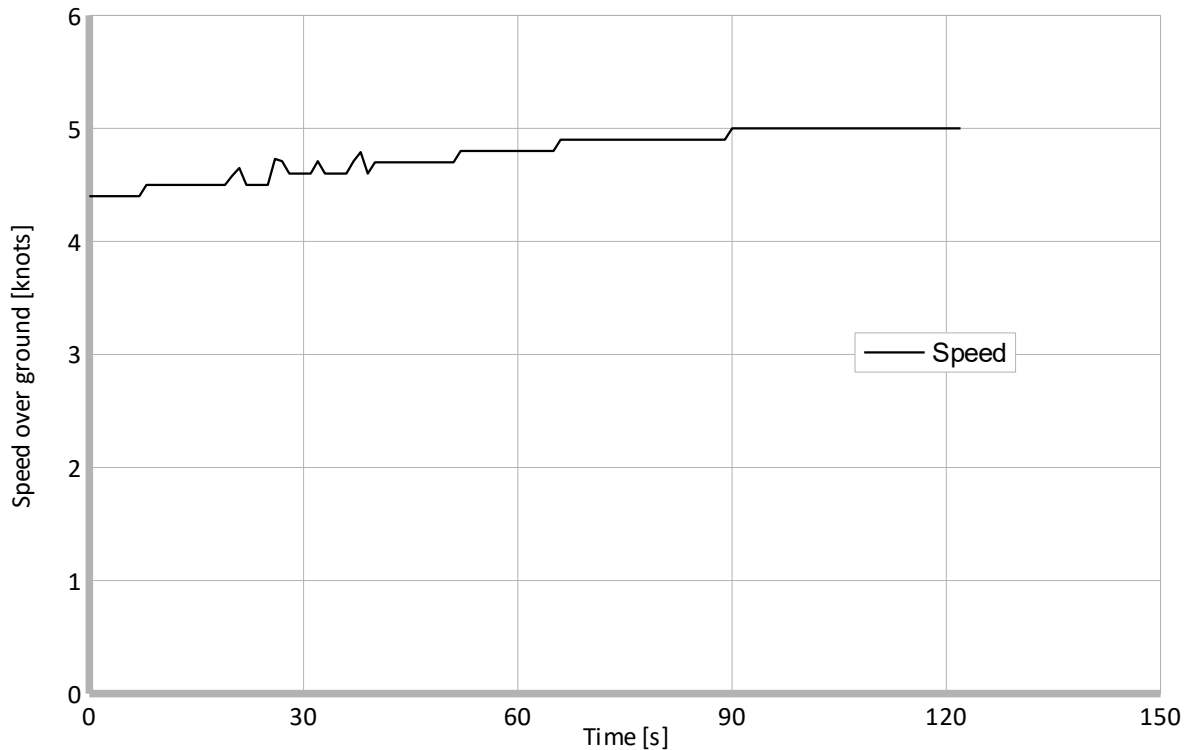
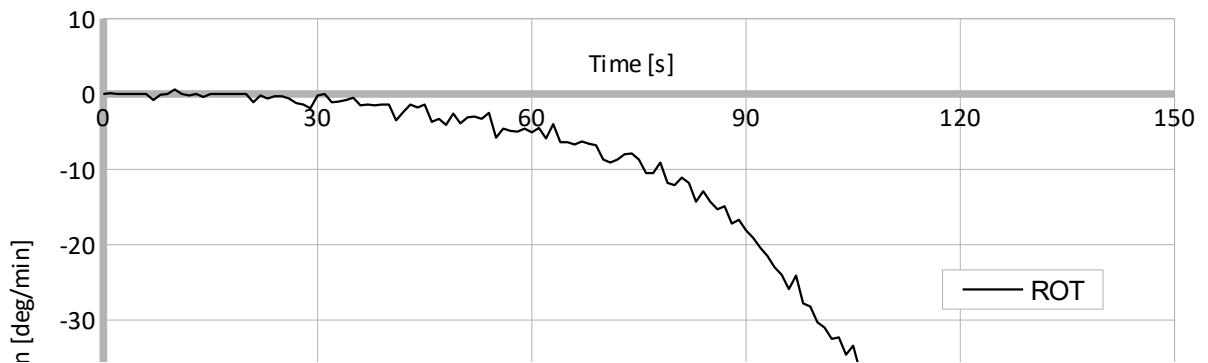
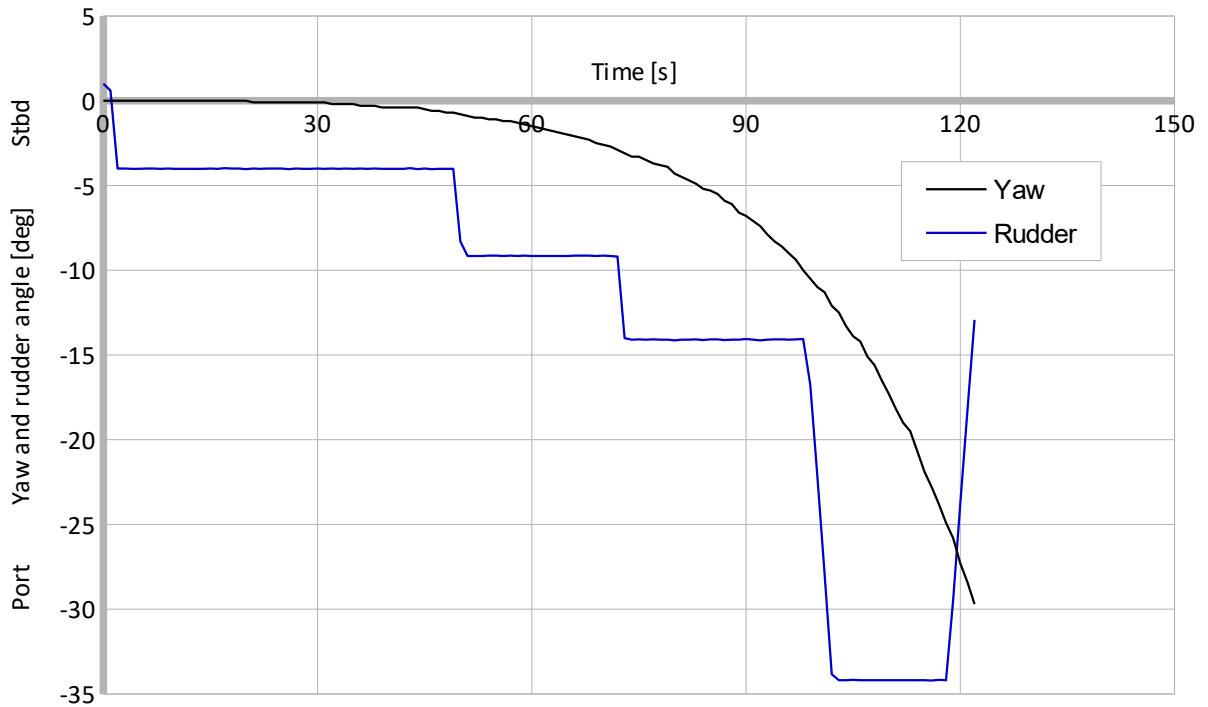

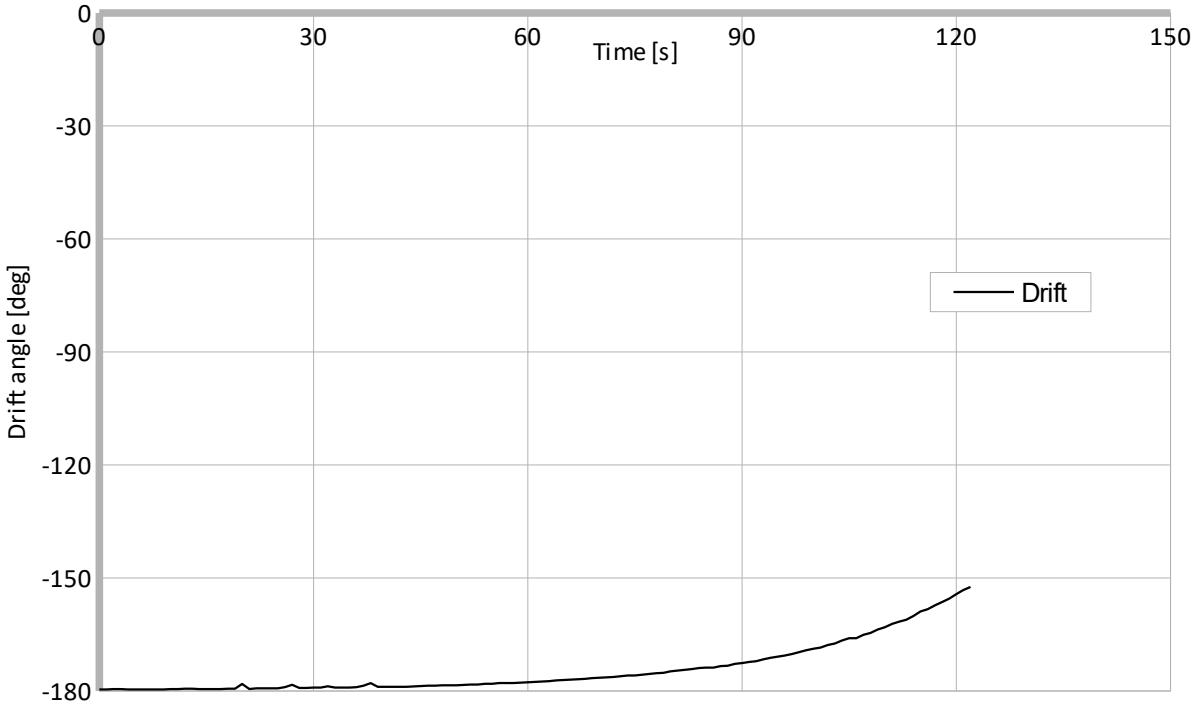

Crabbing test 27.12.2014			
Wind direction [deg]	20	Speed [knots]	1,8
Wind speed [m/s]	4	Drift angle [deg]	70
Initial speed [knots]	0,9	Thruster power [%]	100
Initial heading [deg]	33	Rudder angle [deg] stbd	33

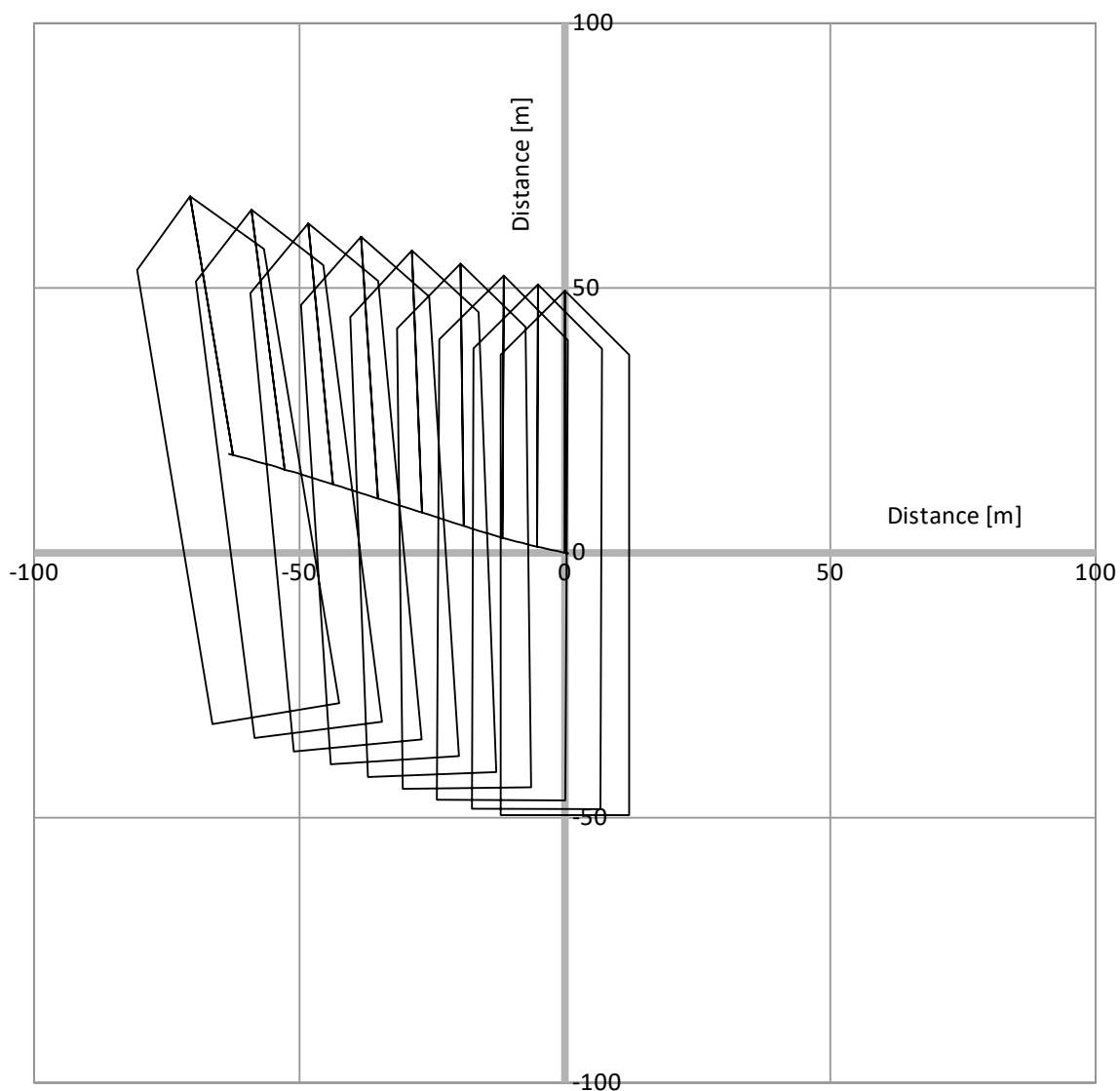

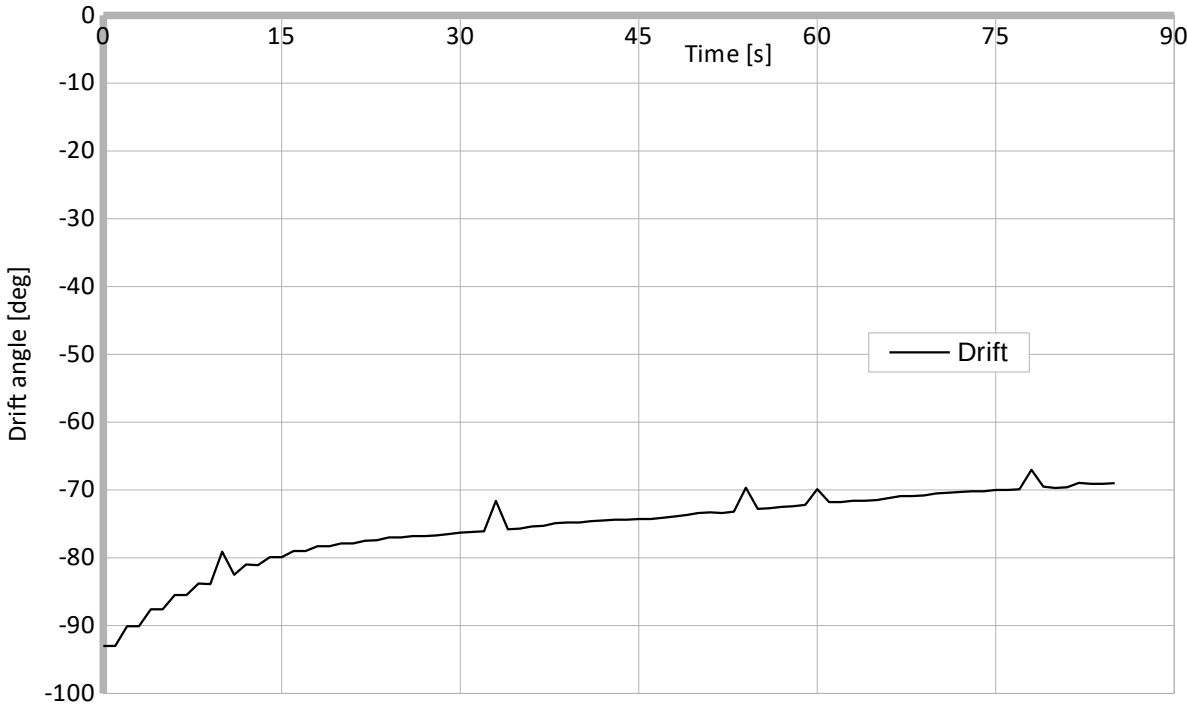
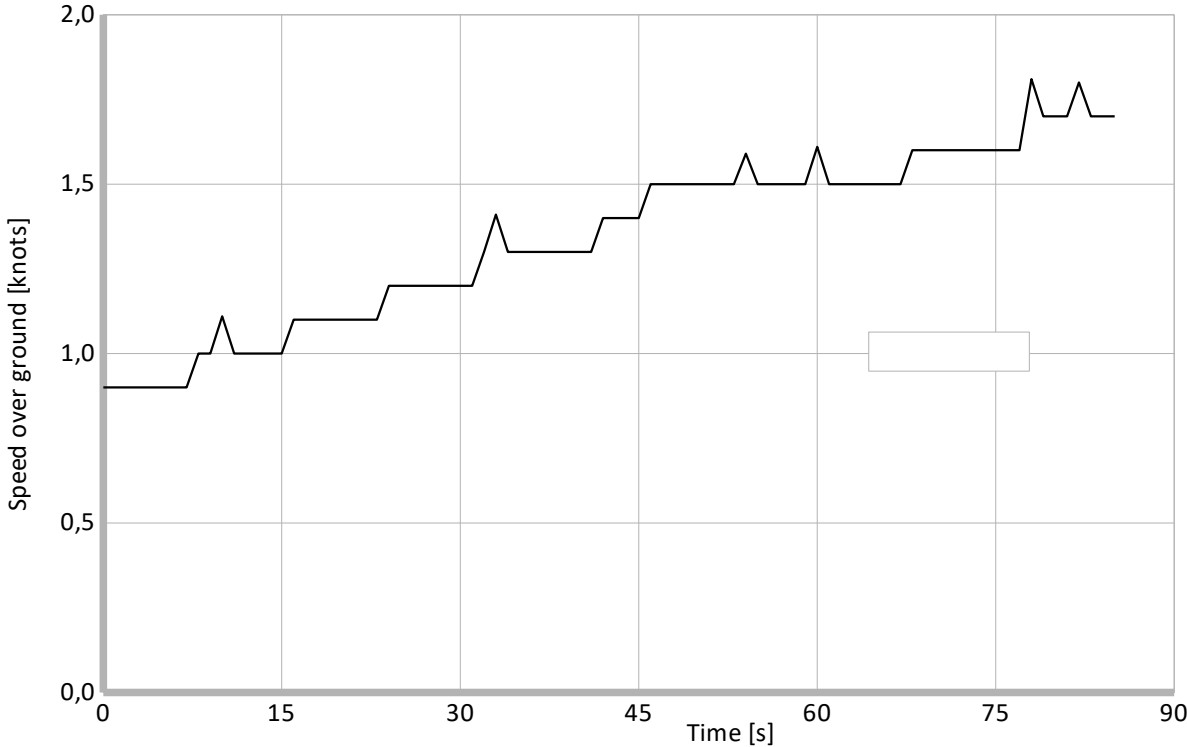

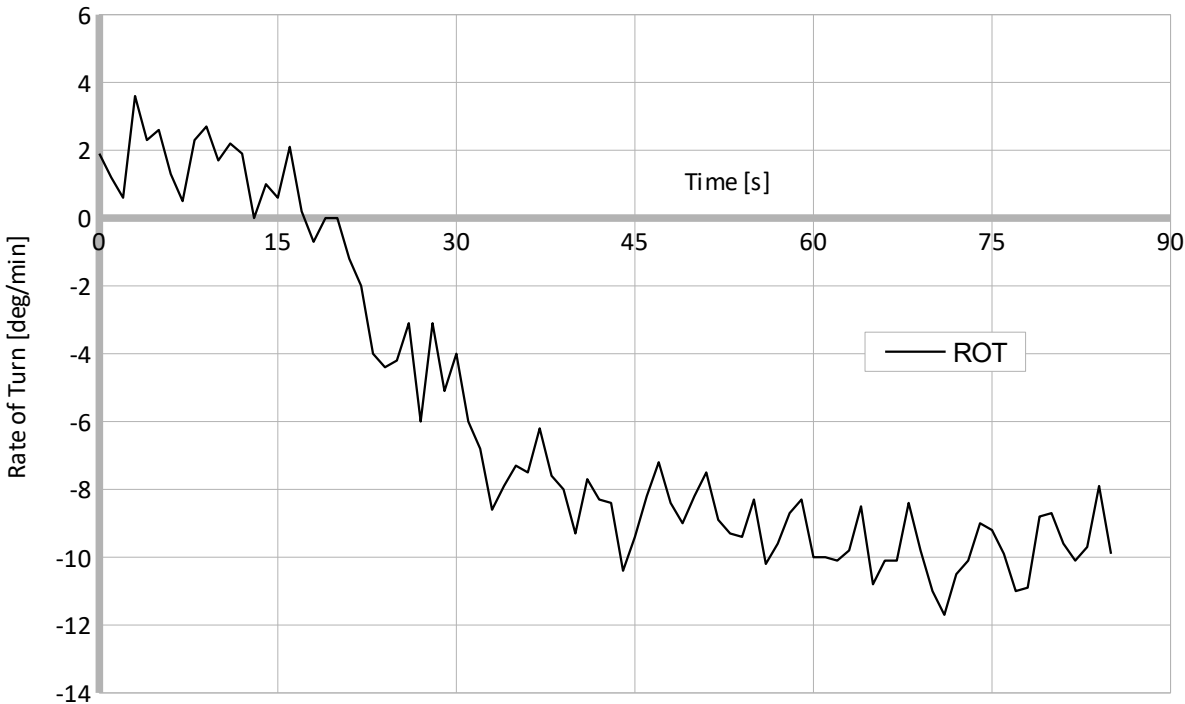
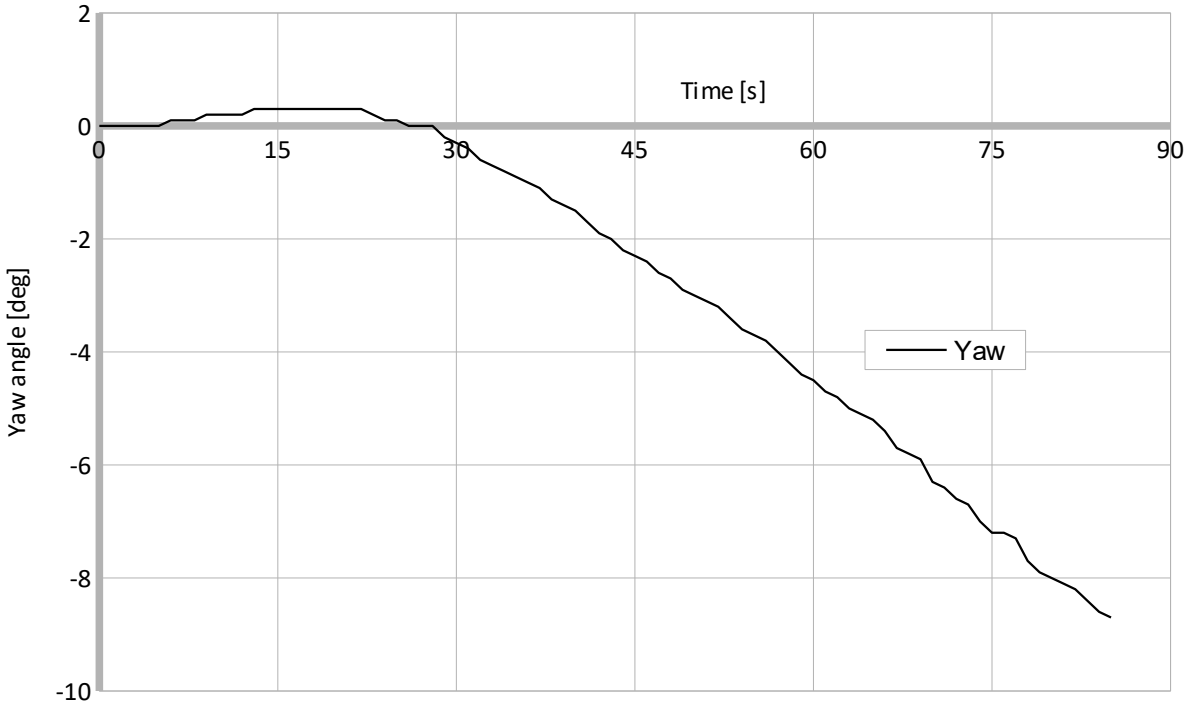

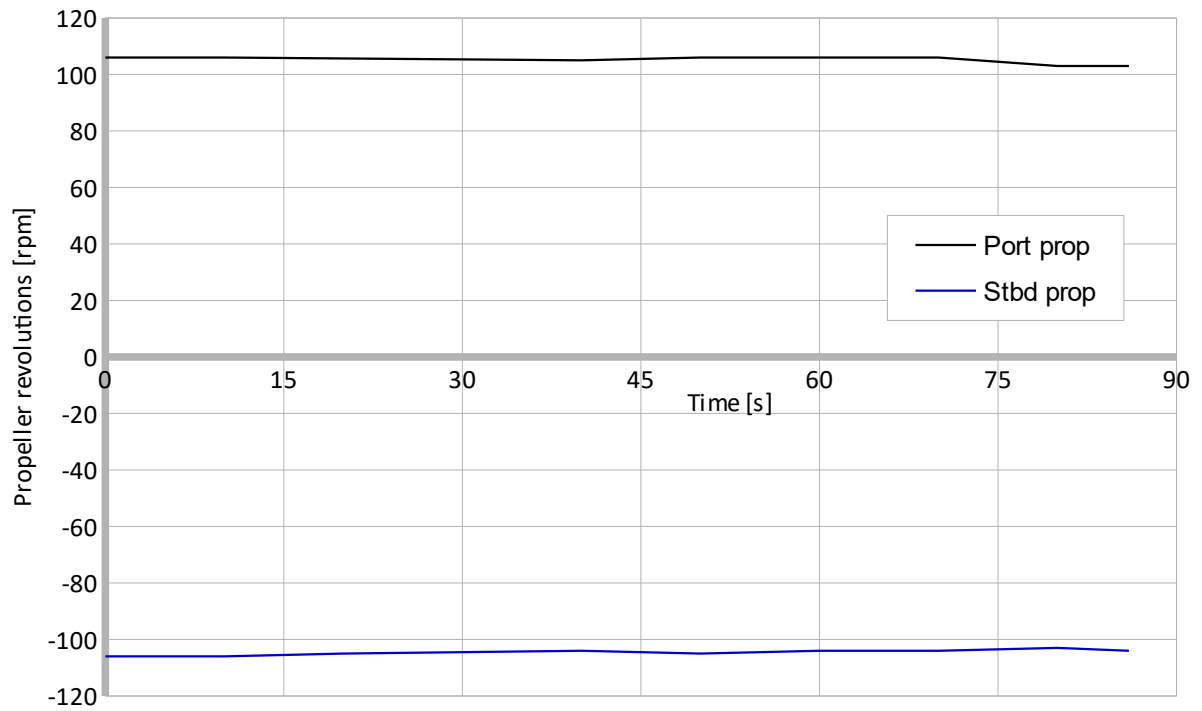

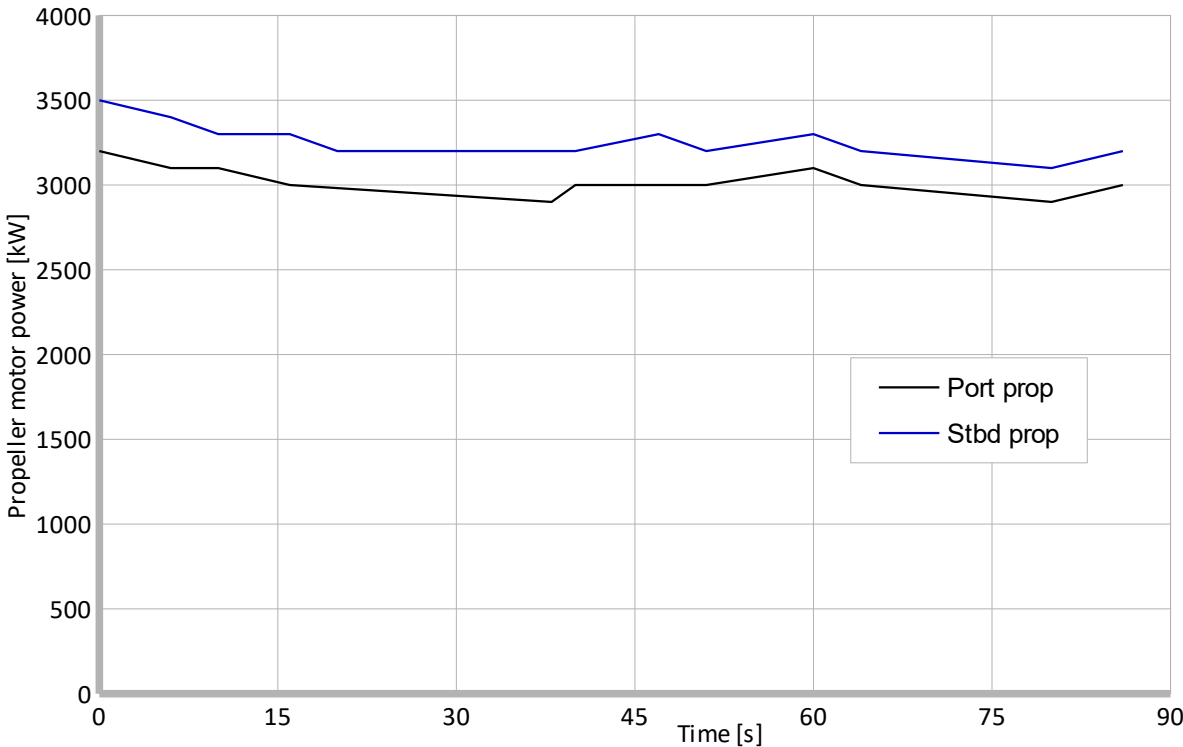
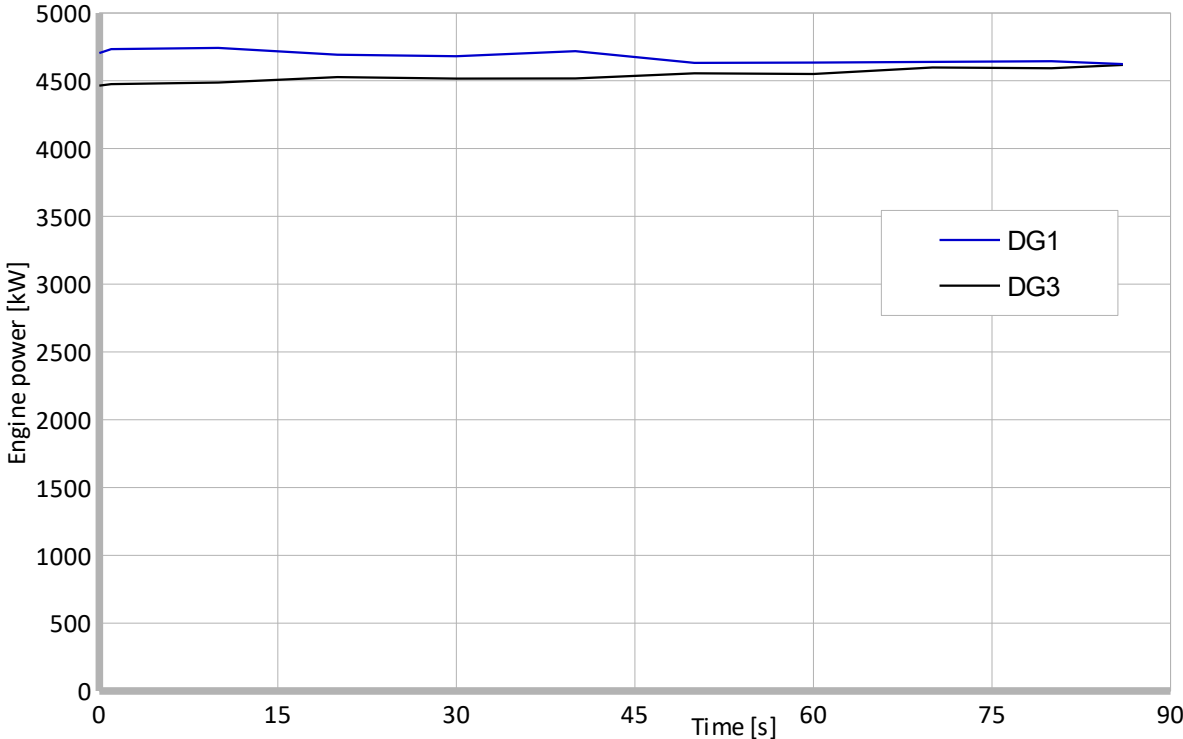

Acceleration turning circle with 1+1 diesel generators			
27.12.2014			
Wind direction [deg]	20	Time to turn 180 degrees [s]	139
Wind speed [m/s]	4	Tactical diameter [m]	374
		Time to turn 360 degrees [s]	247
Initial speed [knots]	0	Steady diameter [m]	406
Initial heading [deg]	351	Steady drift [deg]	22
Advance [m]	184	Rate of turn [deg/s]	1,70
		[deg/min]	102
Transfer [m]	156	Steady speed [knots]	9,5
Time to turn 90 degrees [s]	85	Rudder angle [deg]	34

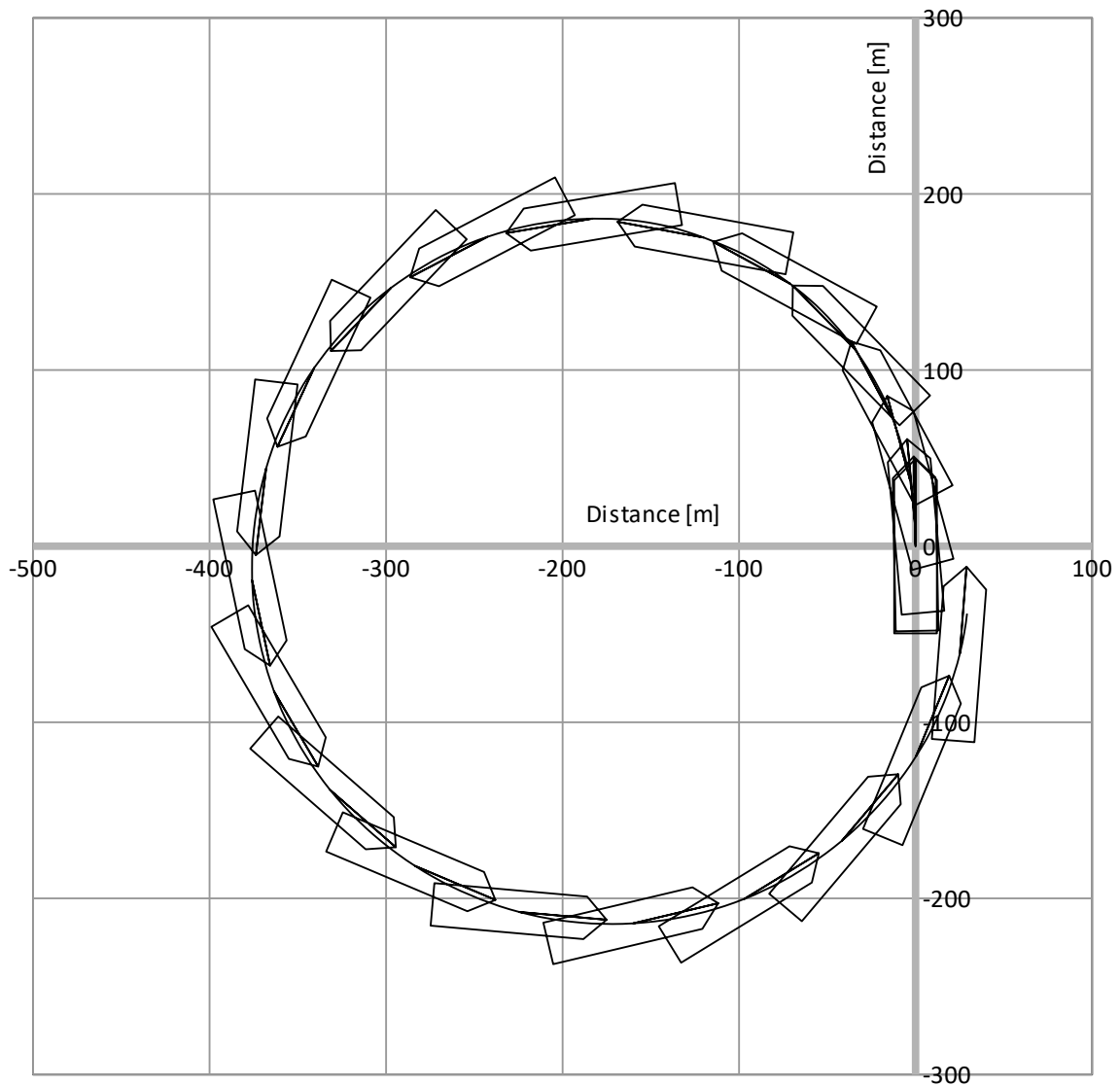

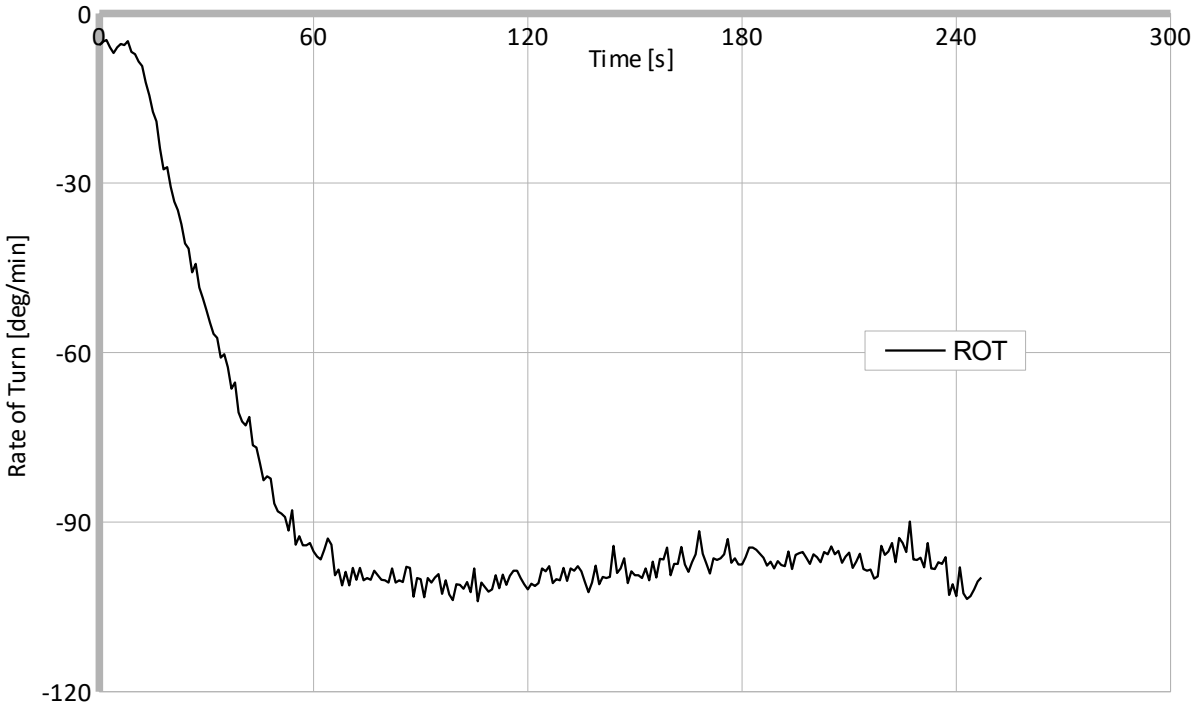
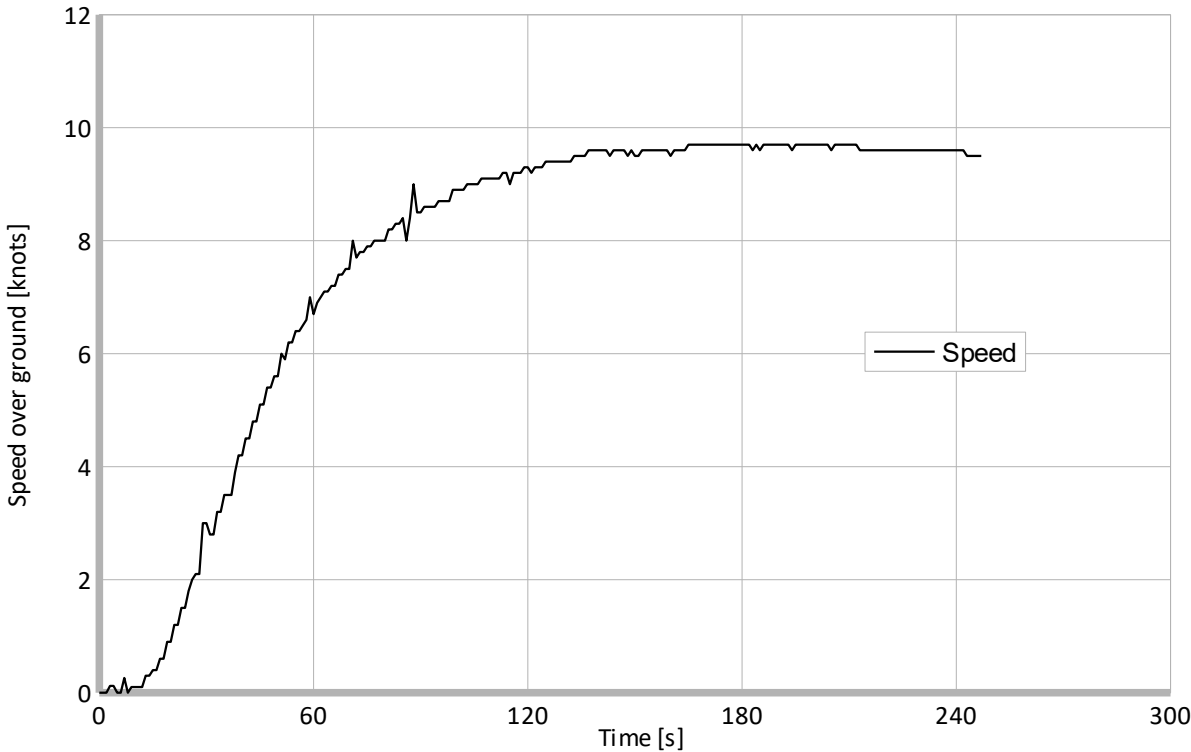

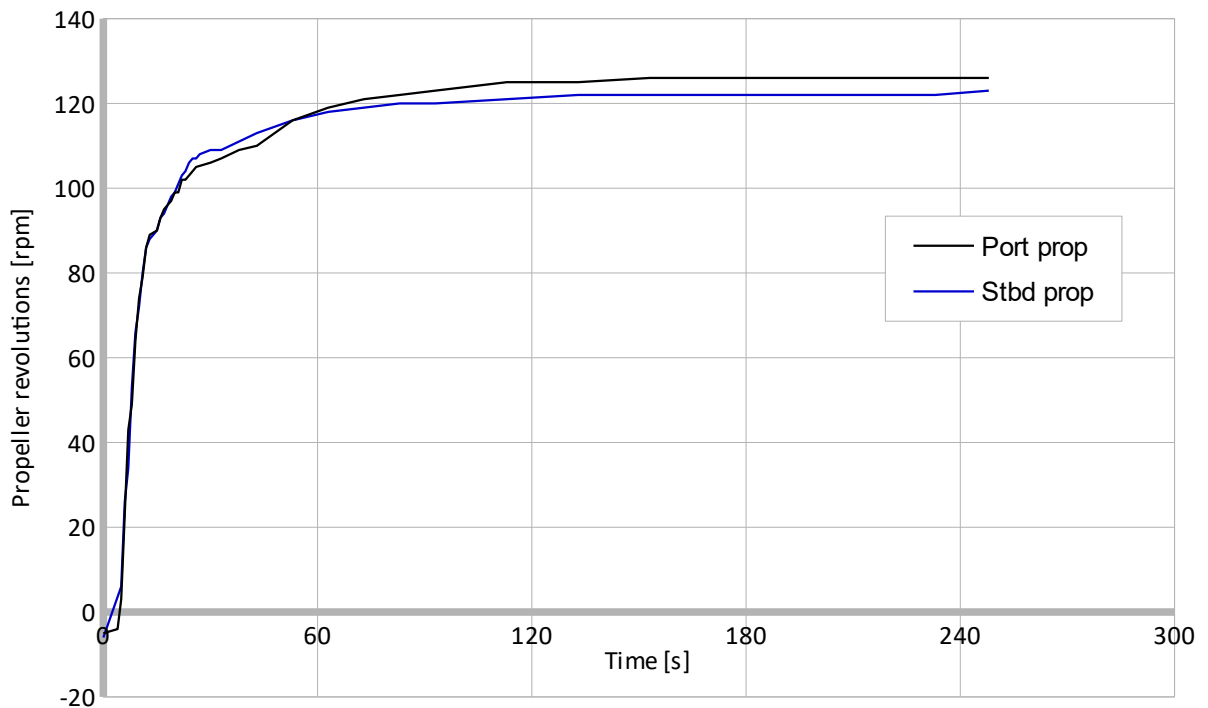
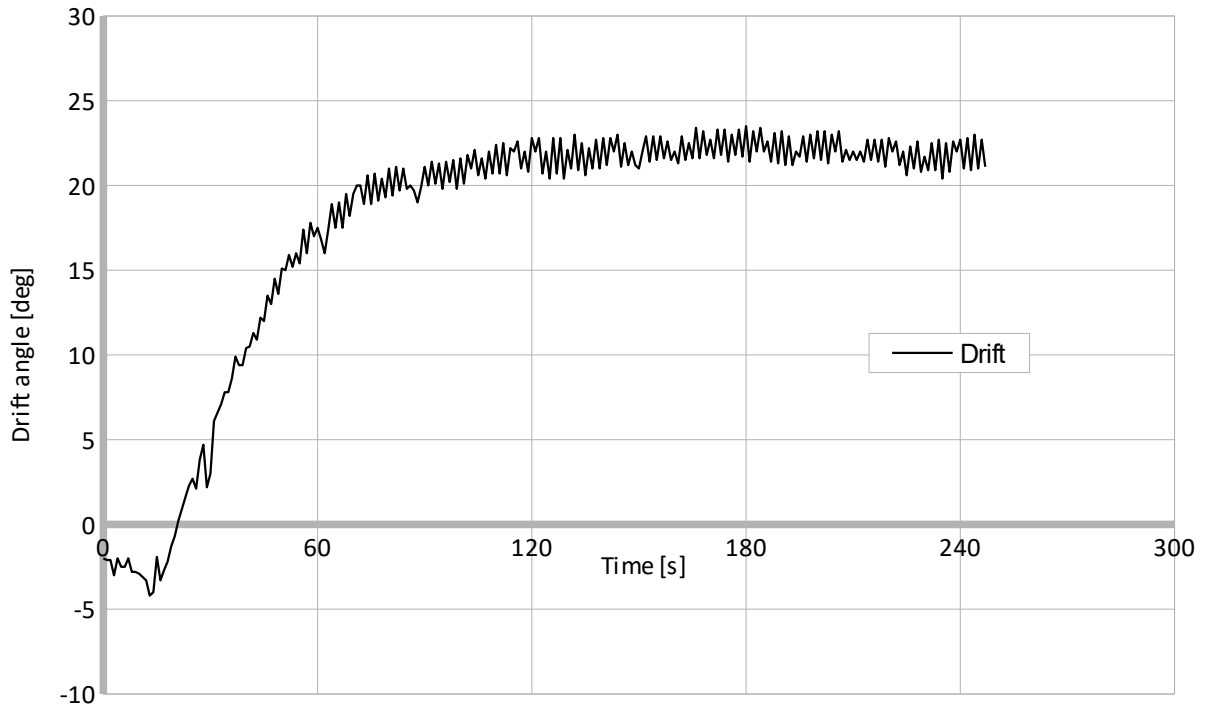

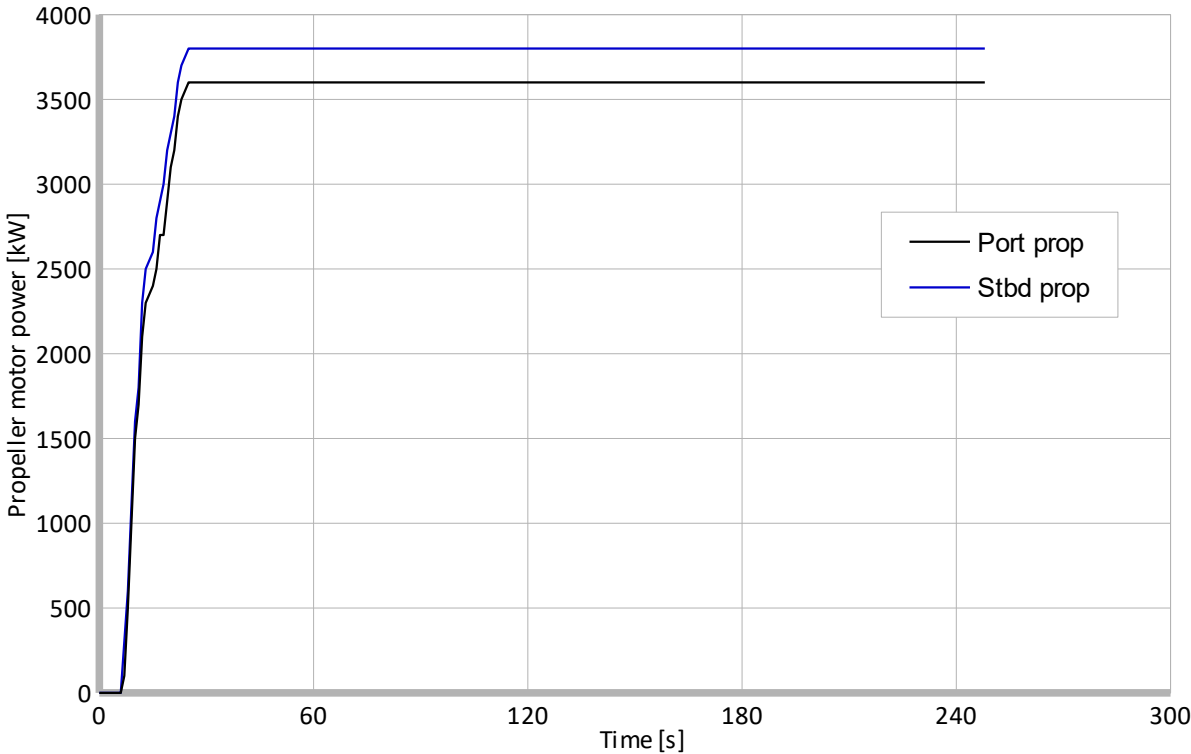
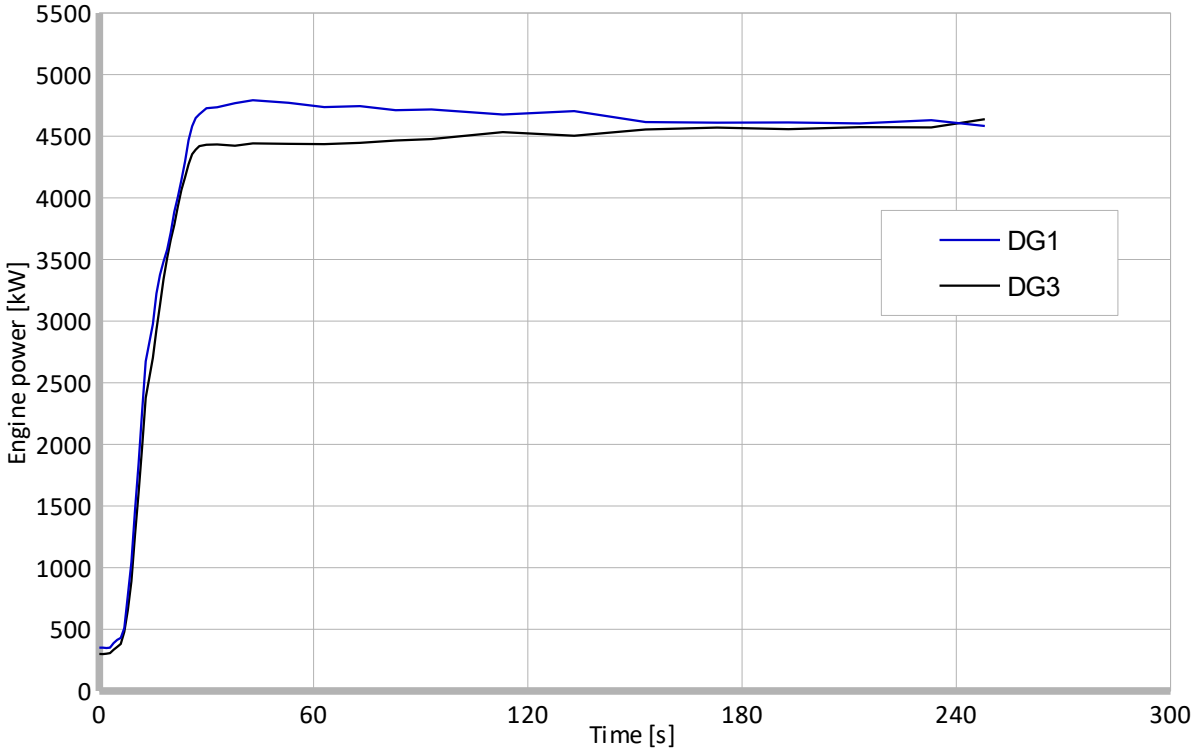

Deceleration turn with 1+1 diesel generators			
27.12.2014			
Wind direction [deg]	20	Initial drift [deg]	22
Wind speed [m/s]	4	Time to turn 90 degrees [s]	99
Initial speed [knots]	9,5	Rudder angle [deg]	34
Initial heading [deg]	346	Residual speed [knots]	3,1
Initial rate of turn [deg/s]	1,70	Residual rate of turn [deg/s]	0,38
	[deg/min]]		[deg/min]
	102		23

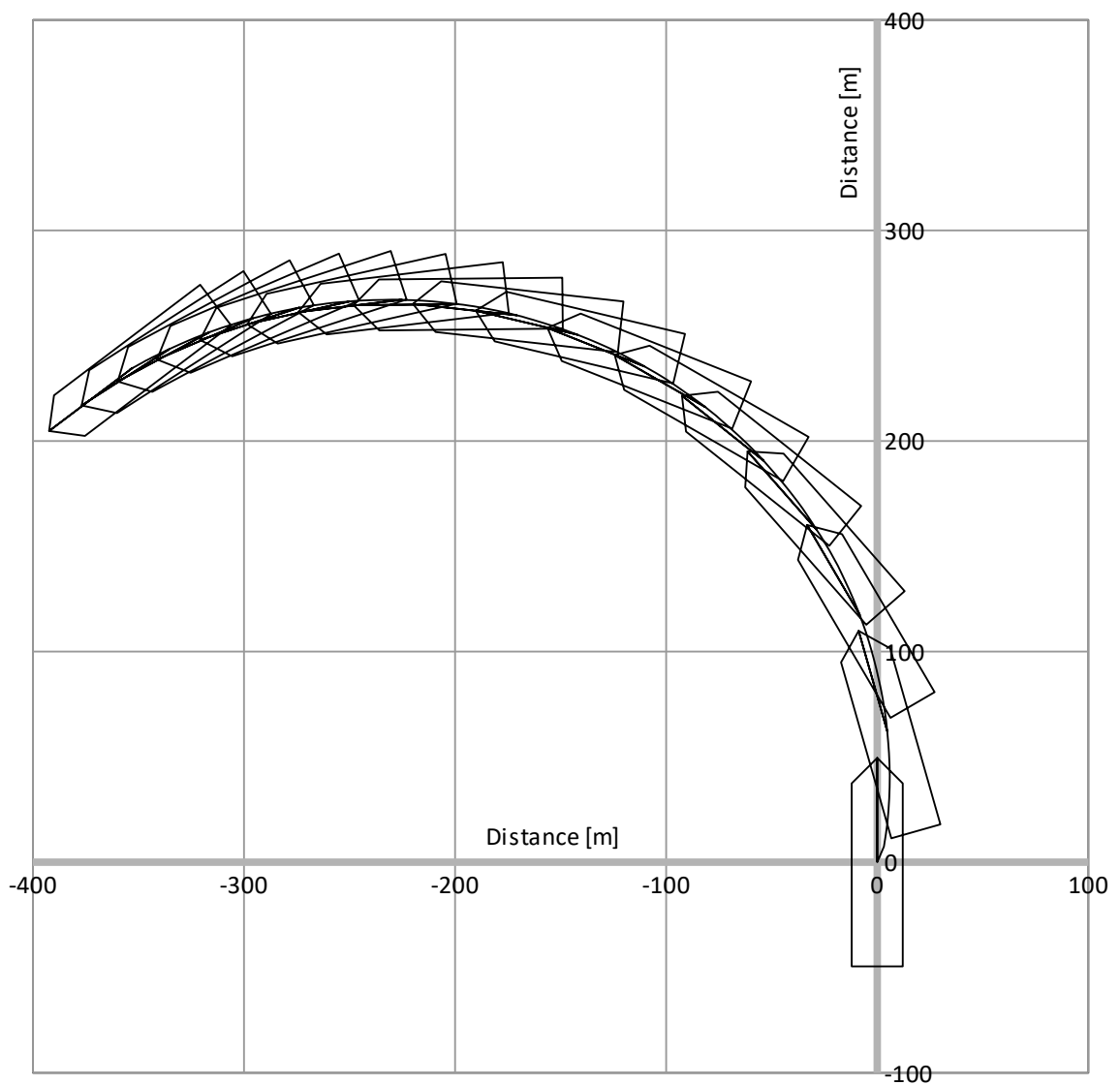

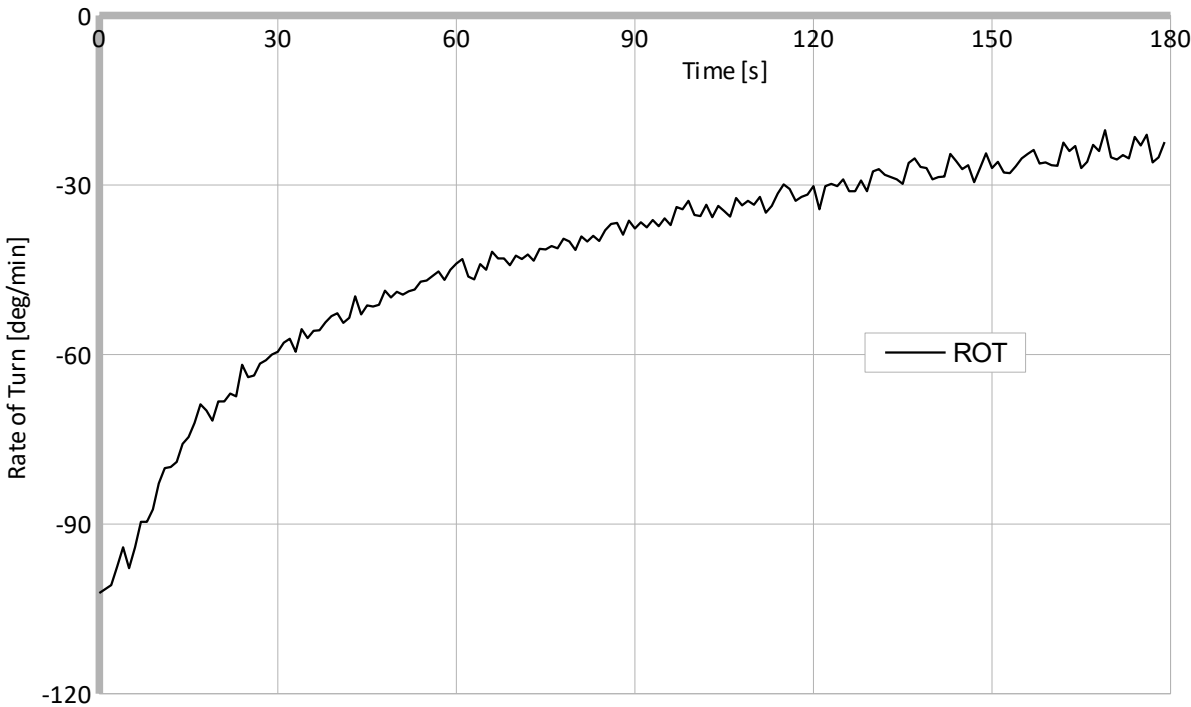
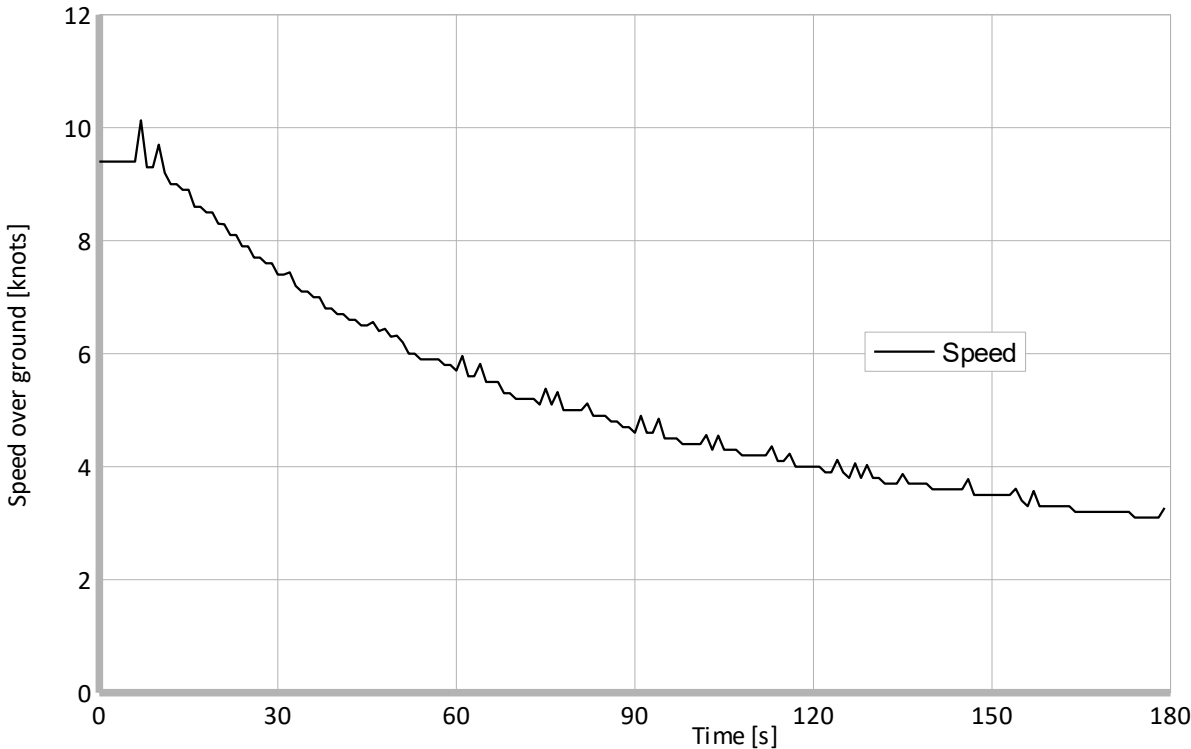

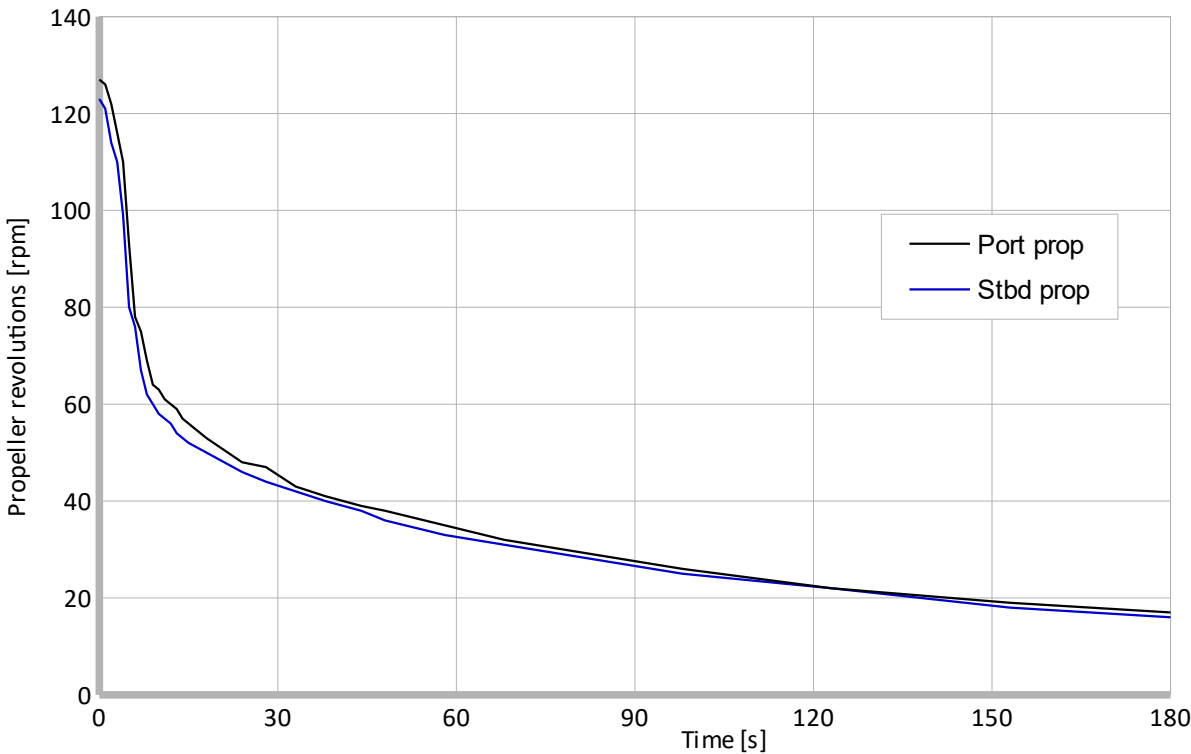
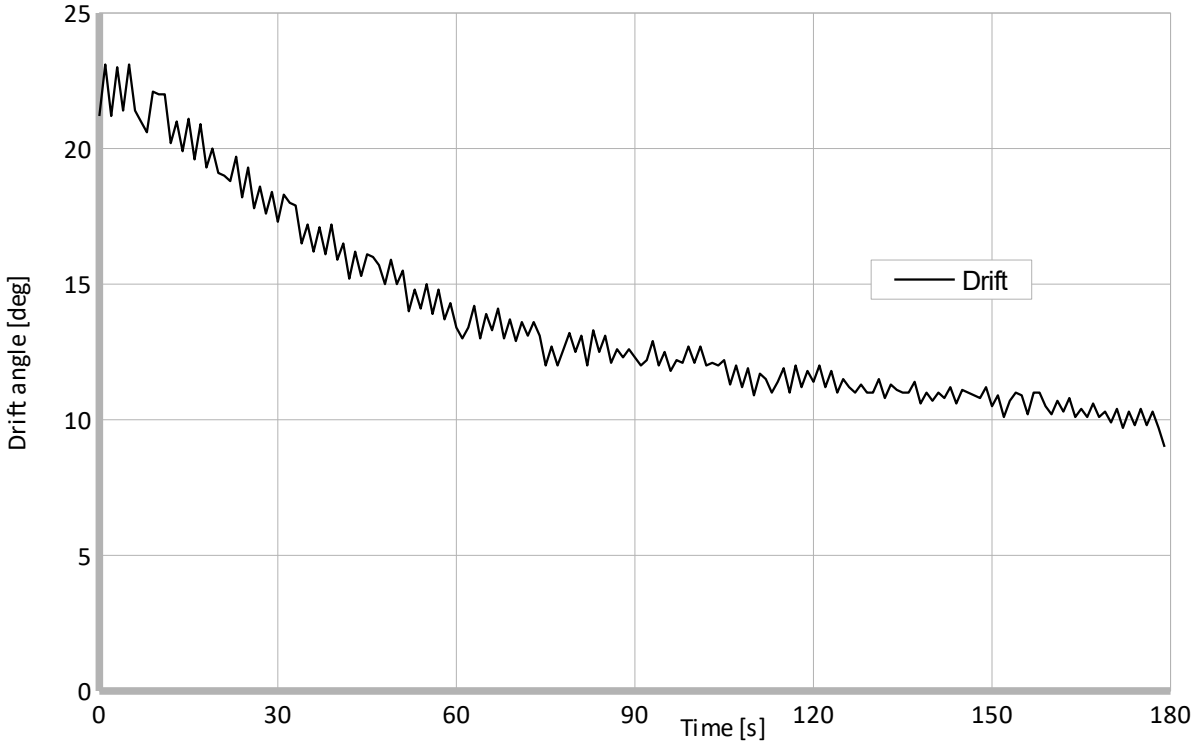

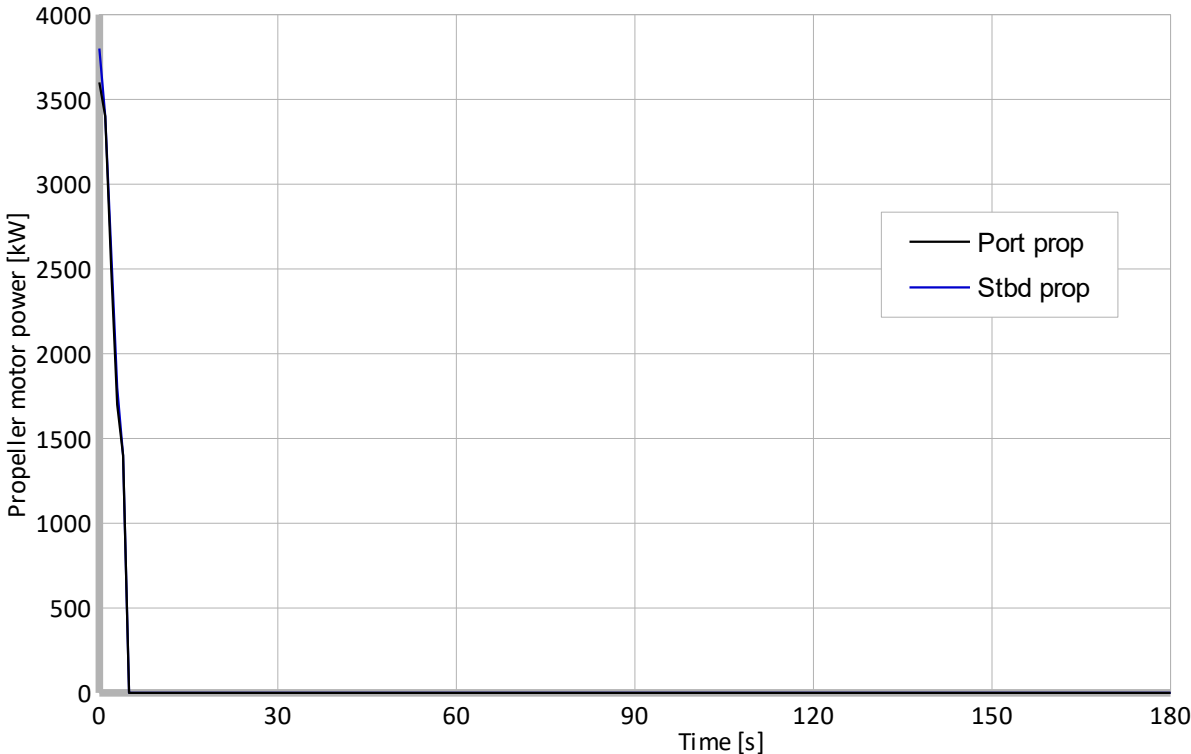
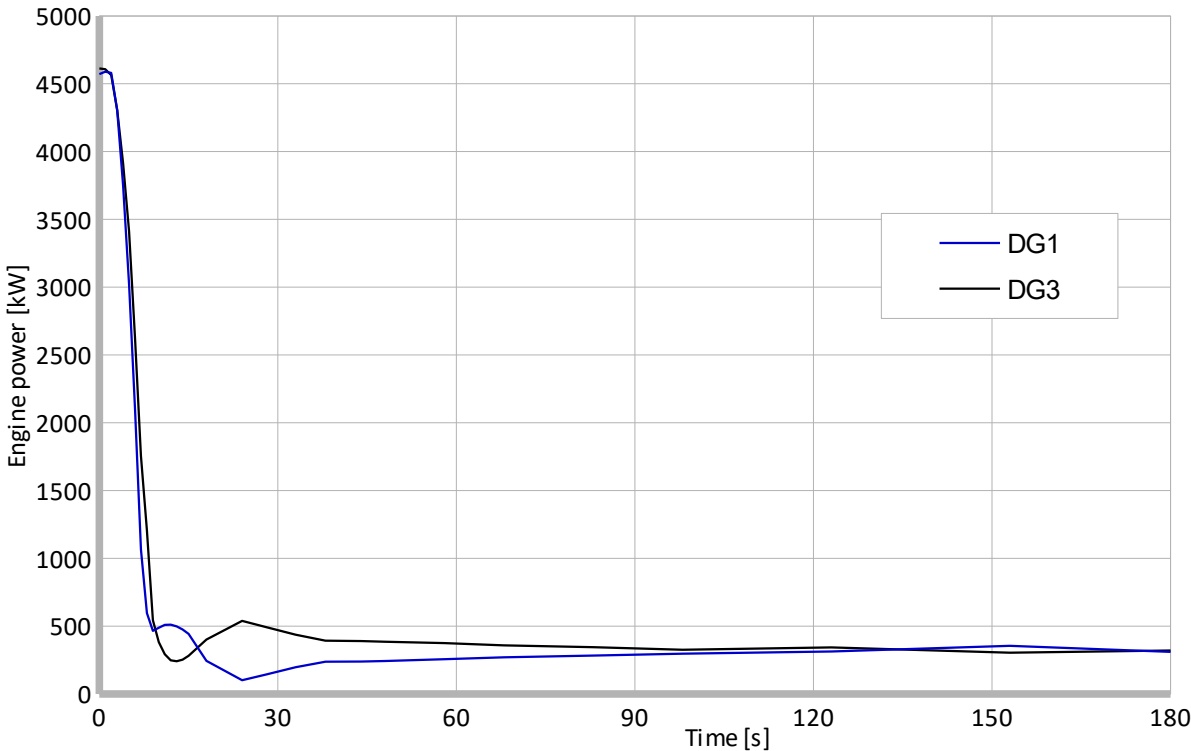

Acceleration turning circle with 2+2 diesel generators			
27.12.2014			
Wind direction [deg]	20	Time to turn 180 degrees [s]	123
Wind speed [m/s]	4	Tactical diameter [m]	388
		Time to turn 360 degrees [s]	213
Initial speed [knots]	0,3	Steady diameter [m]	420
Initial heading [deg]	54	Steady drift [deg]	25
Advance [m]	196	Rate of turn [deg/s]	1,92
		[deg/min]	115
Transfer [m]	164	Steady speed [knots]	11,9
Time to turn 90 degrees [s]	78	Rudder angle [deg]	33

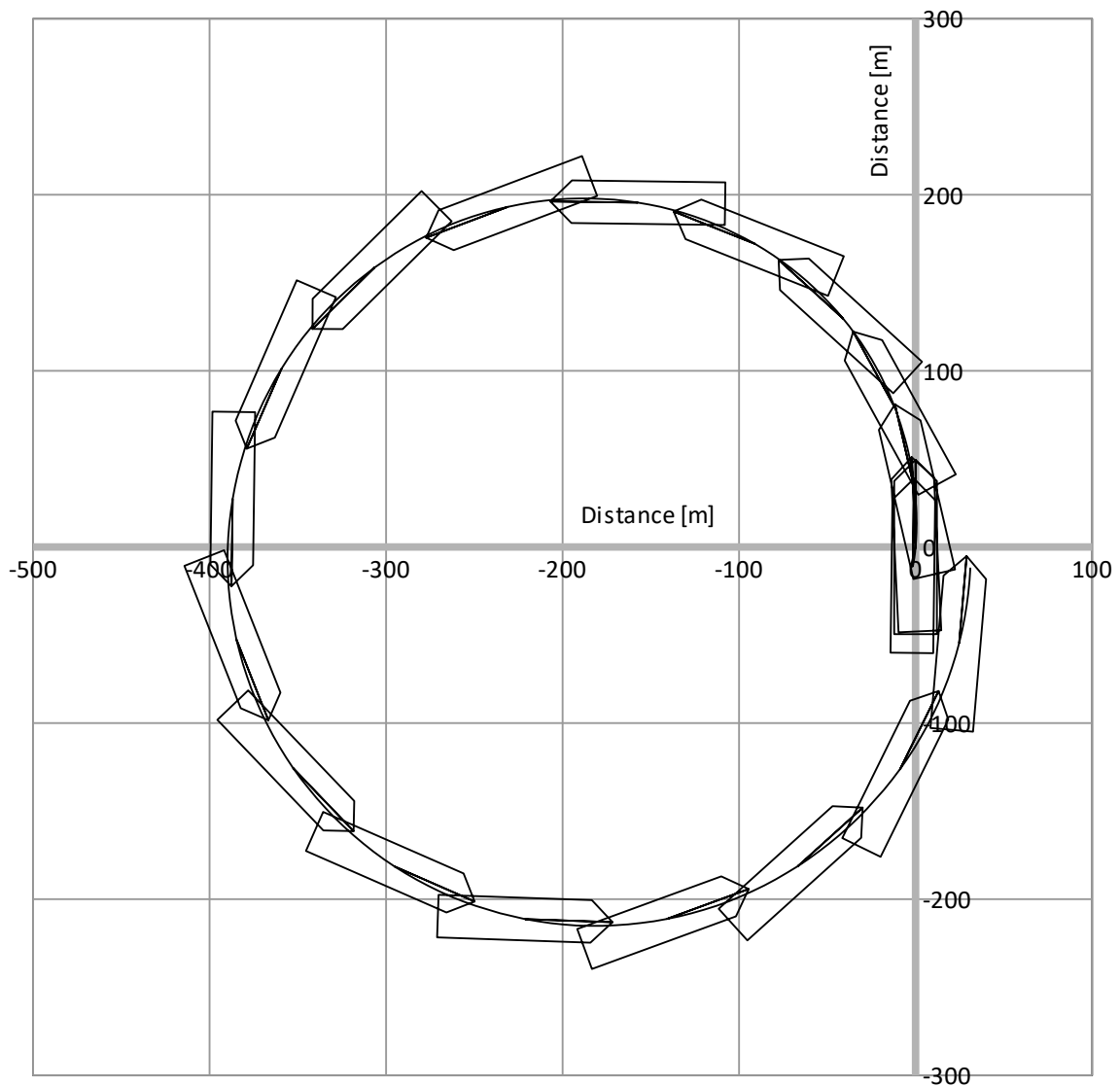

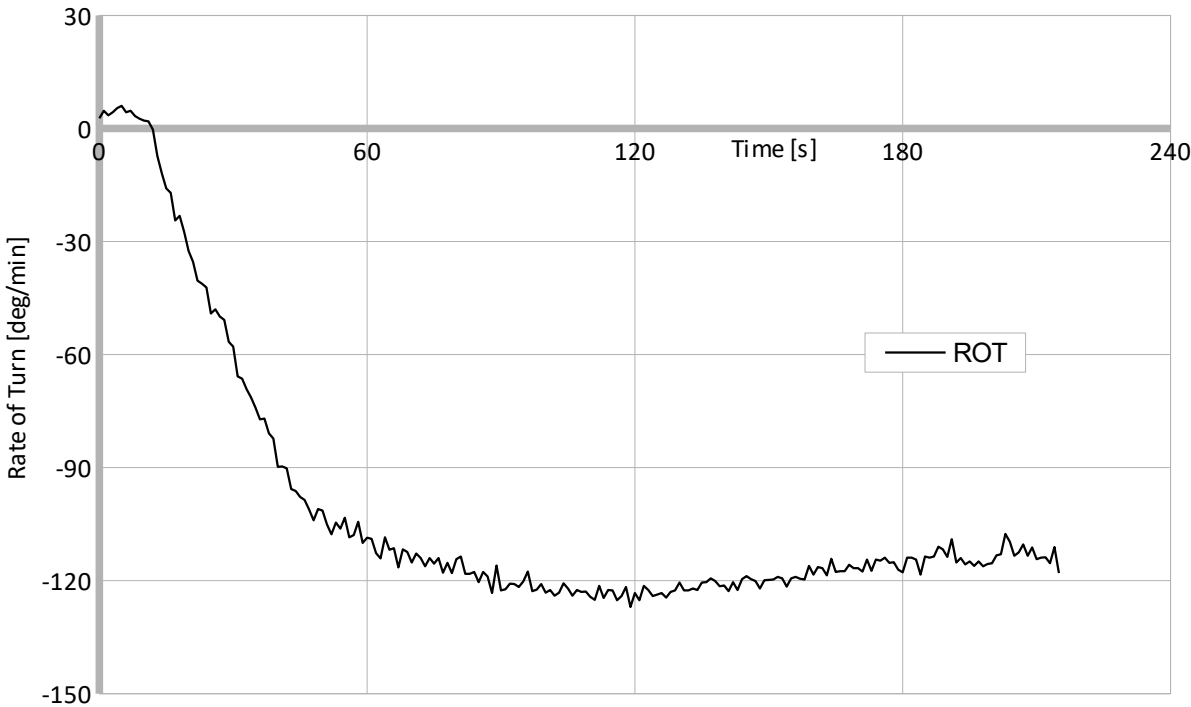
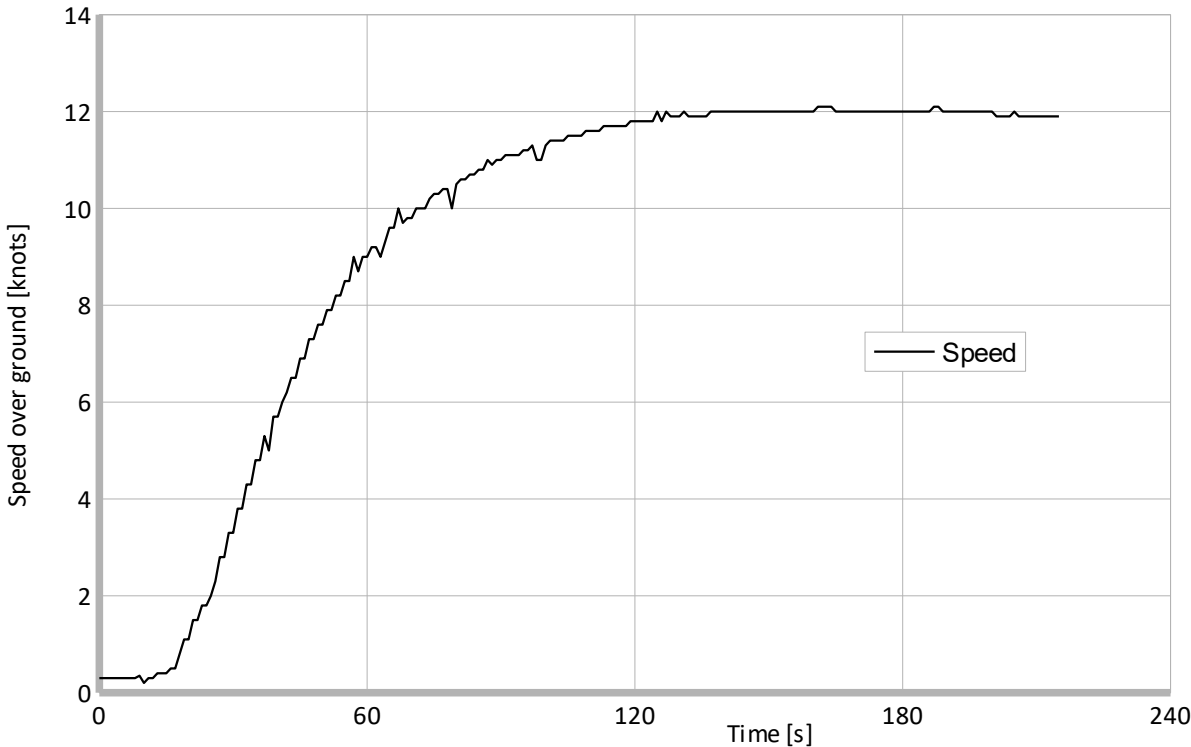

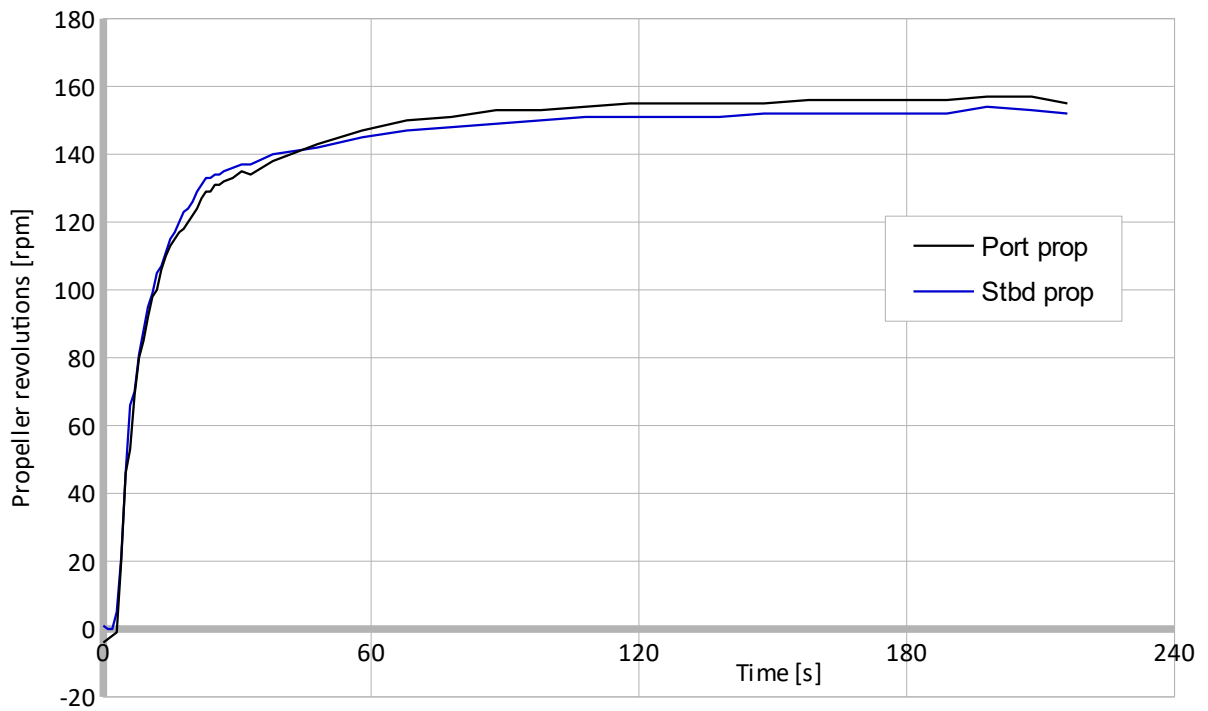
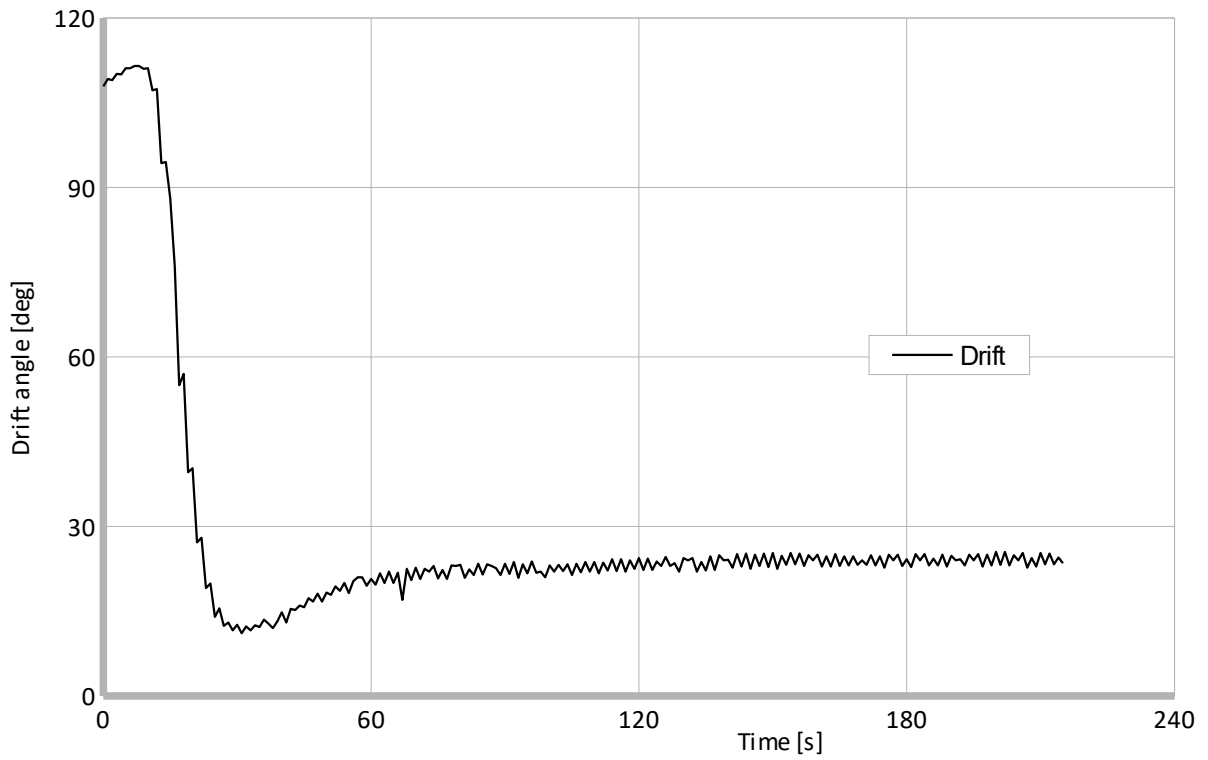

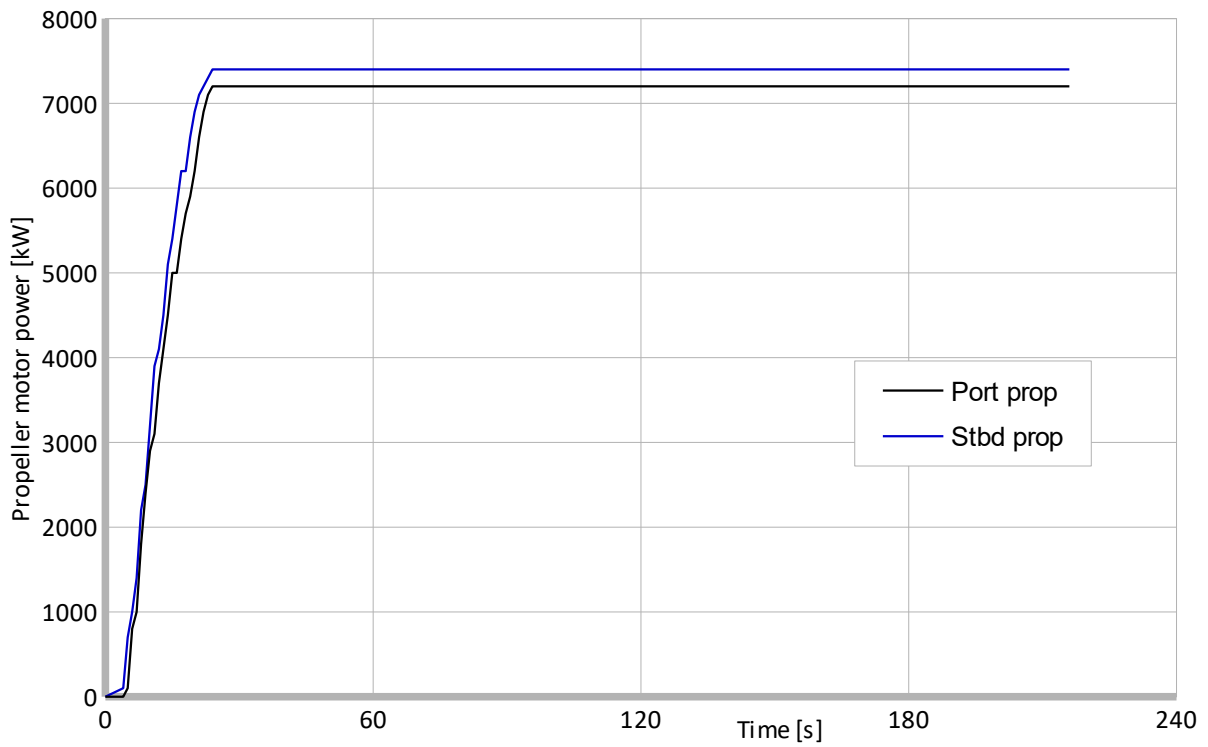
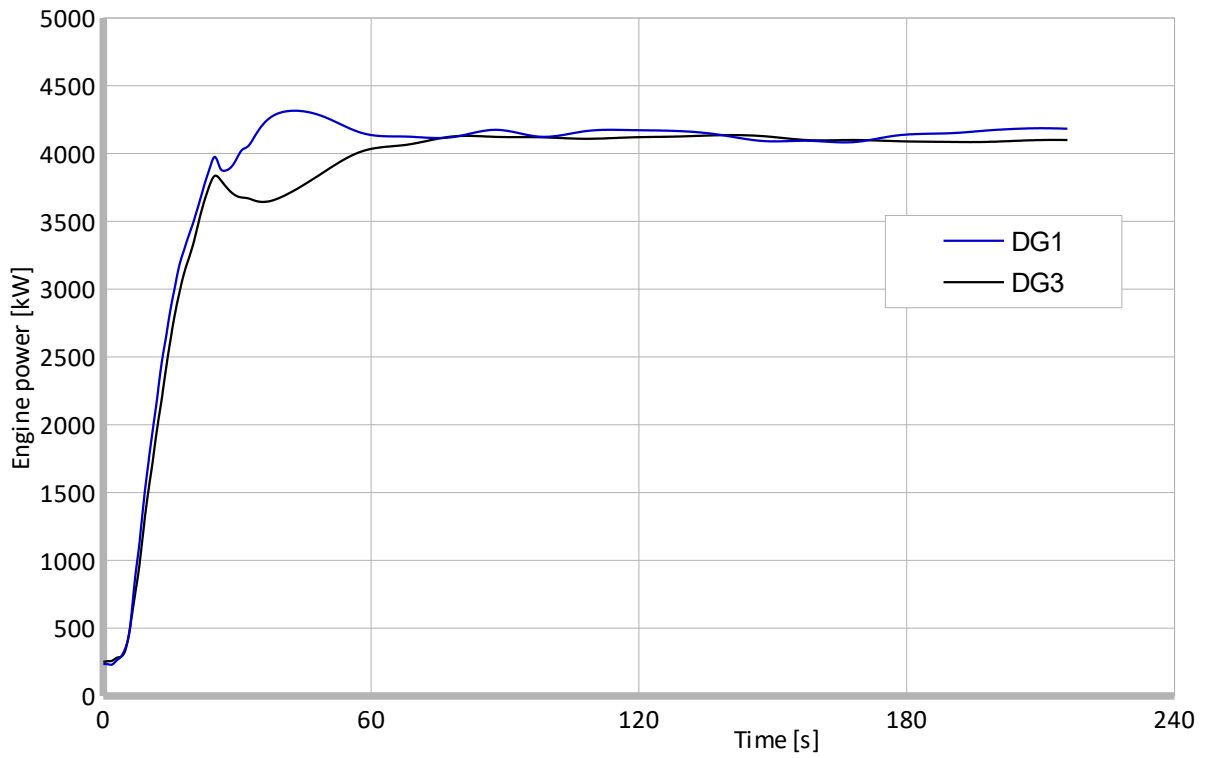

Deceleration turn with 2+2 diesel generators			
27.12.2014			
Wind direction [deg]	20	Initial drift [deg]	25
Wind speed [m/s]	4	Time to turn 90 degrees [s]	92
Initial speed [knots]	11,9	Rudder angle [deg]	33
Initial heading [deg]	45	Residual speed [knots]	2,3
Initial rate of turn [deg/s]	1,92	Residual rate of turn [deg/s]	0,30
[deg/min]]	115	[deg/min]	18

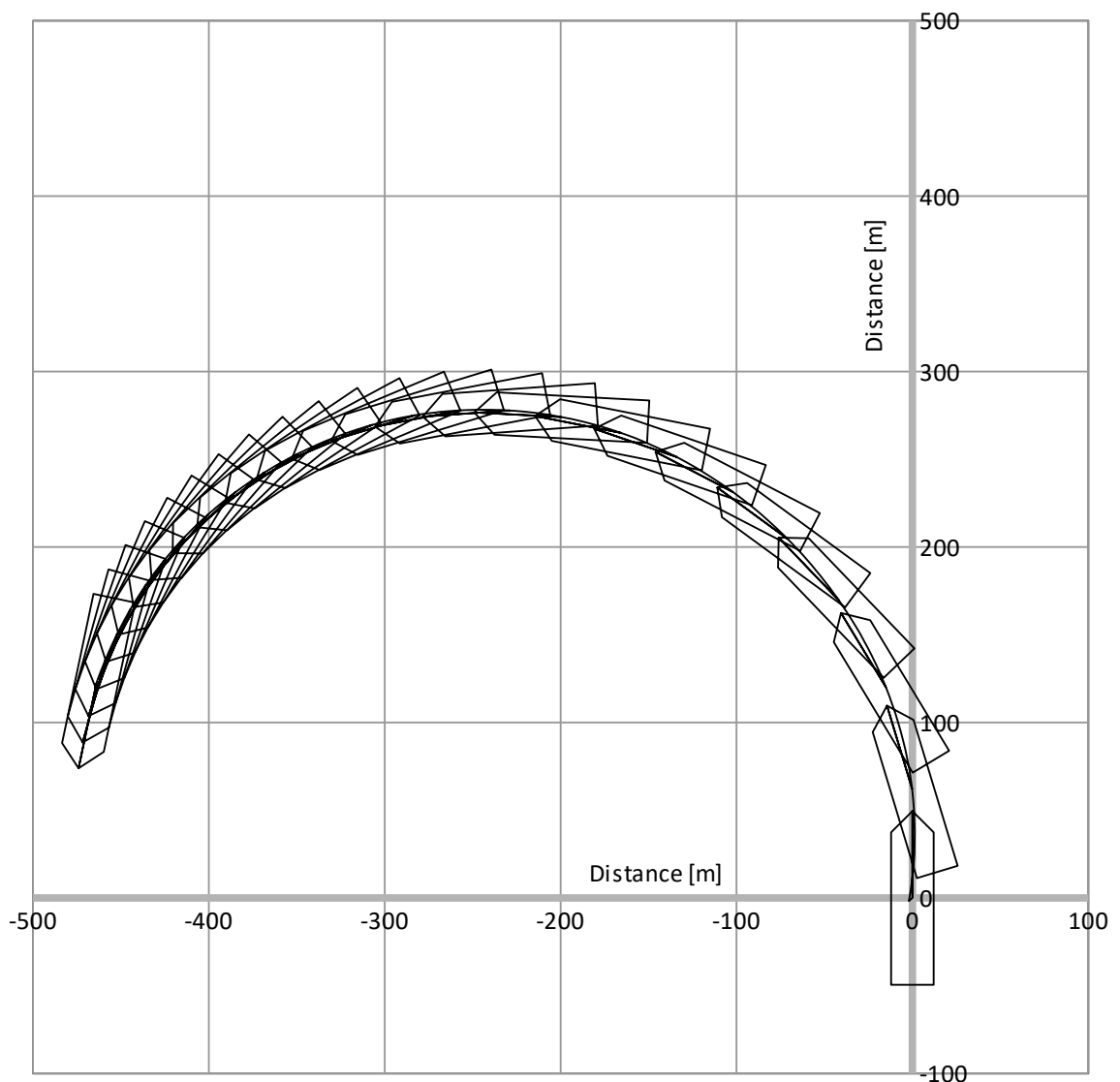

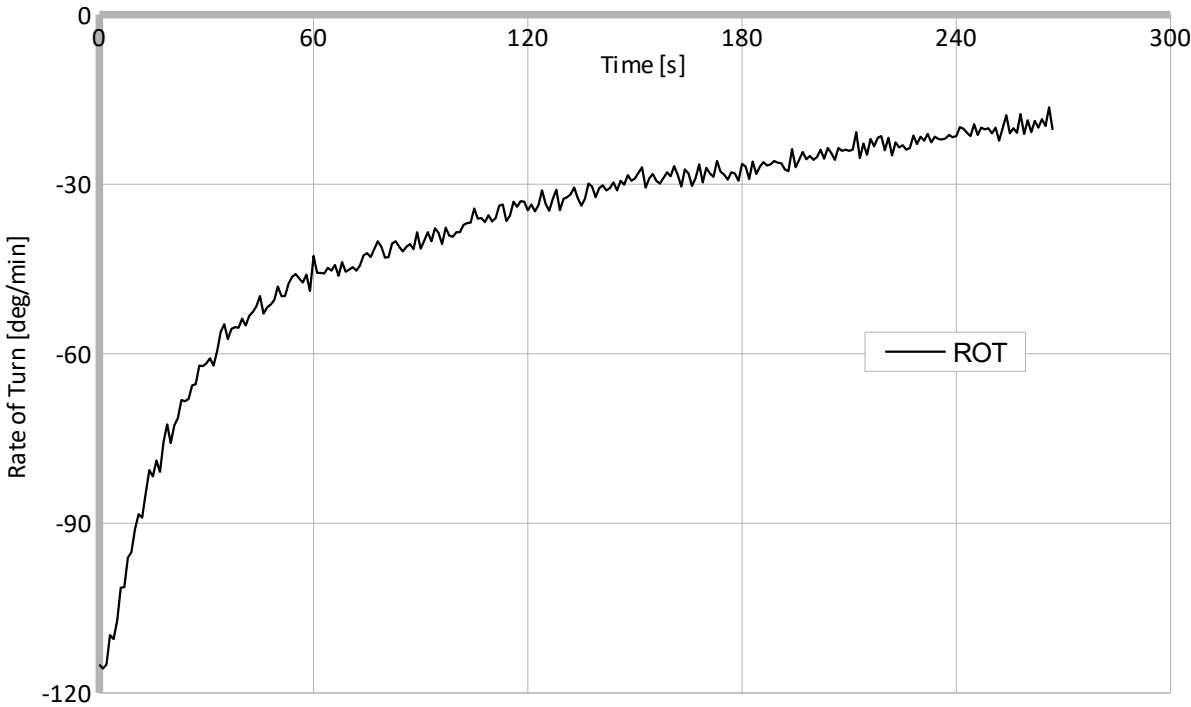
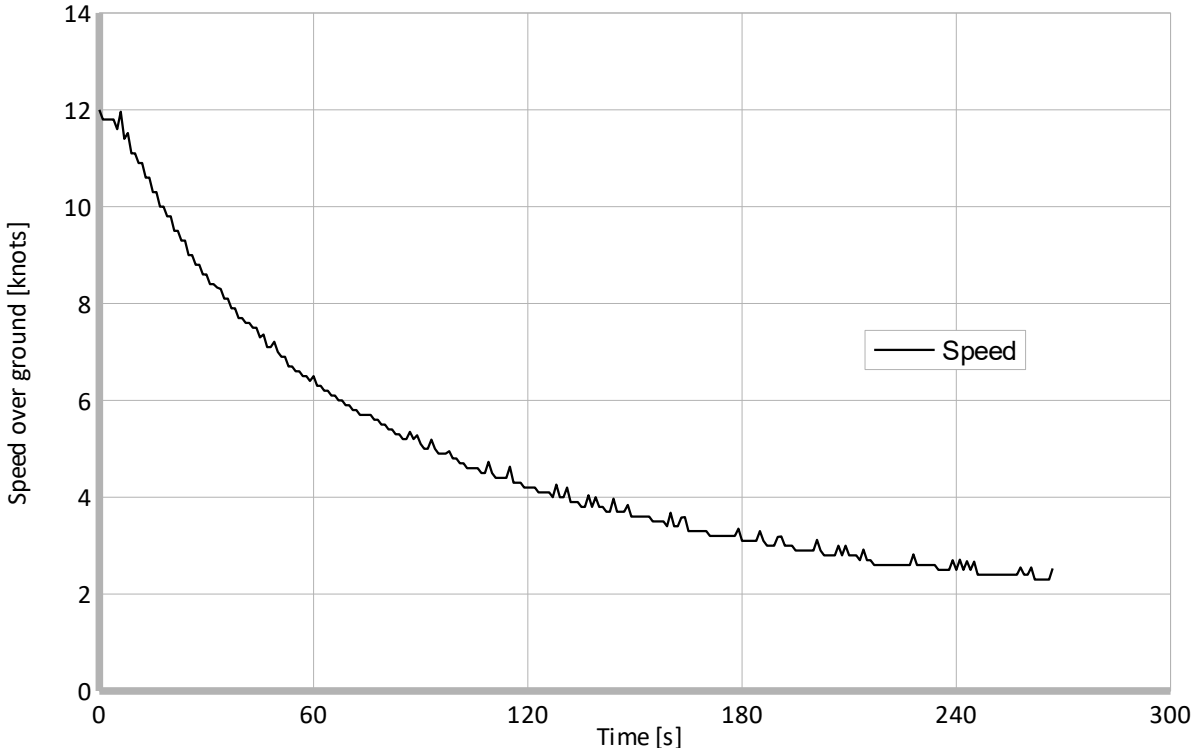

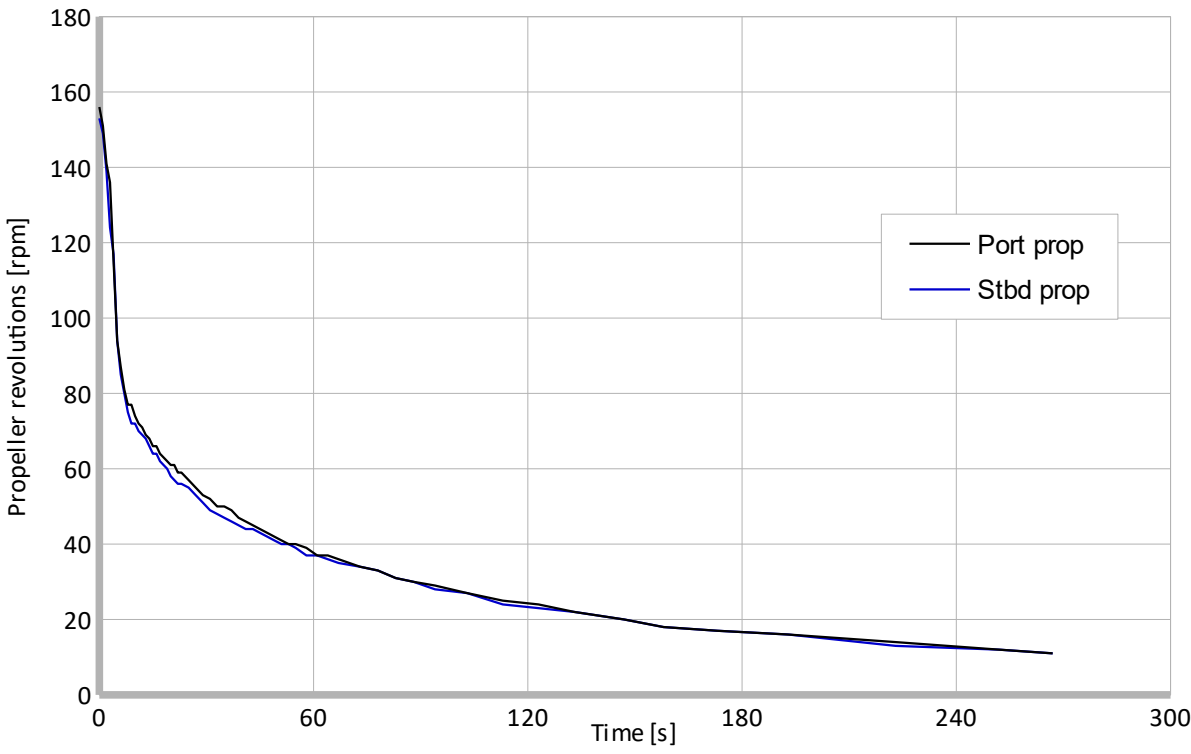
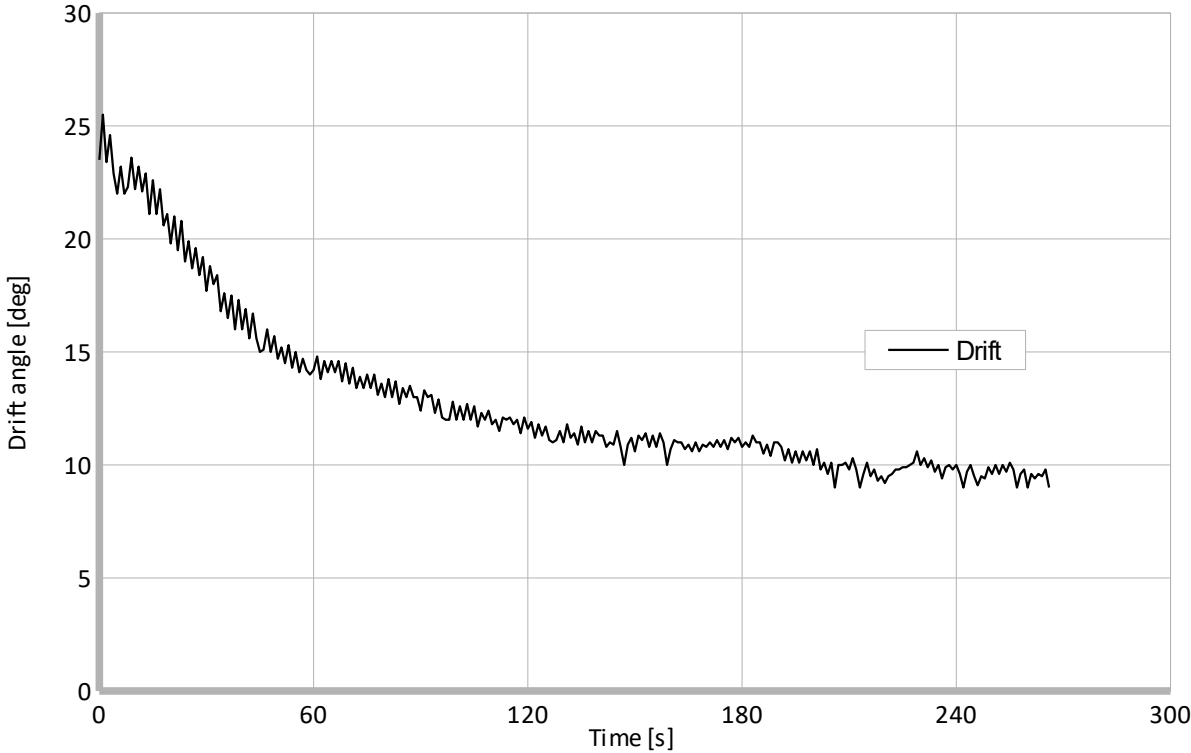

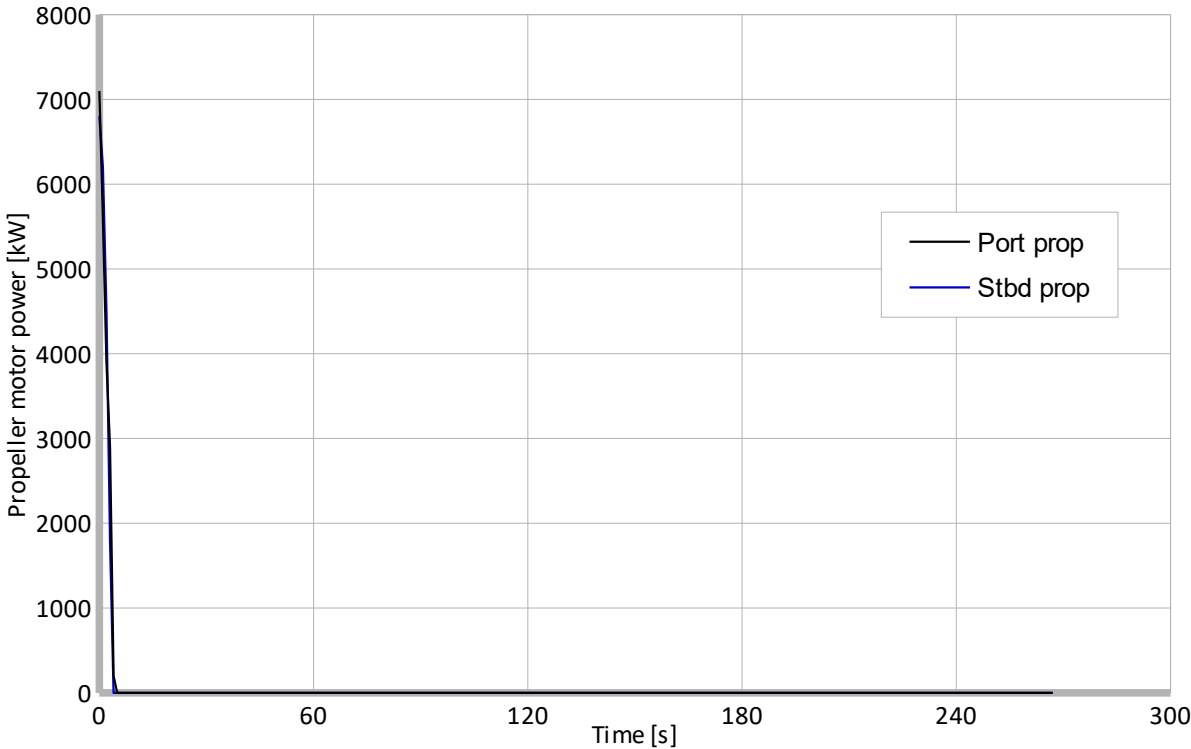
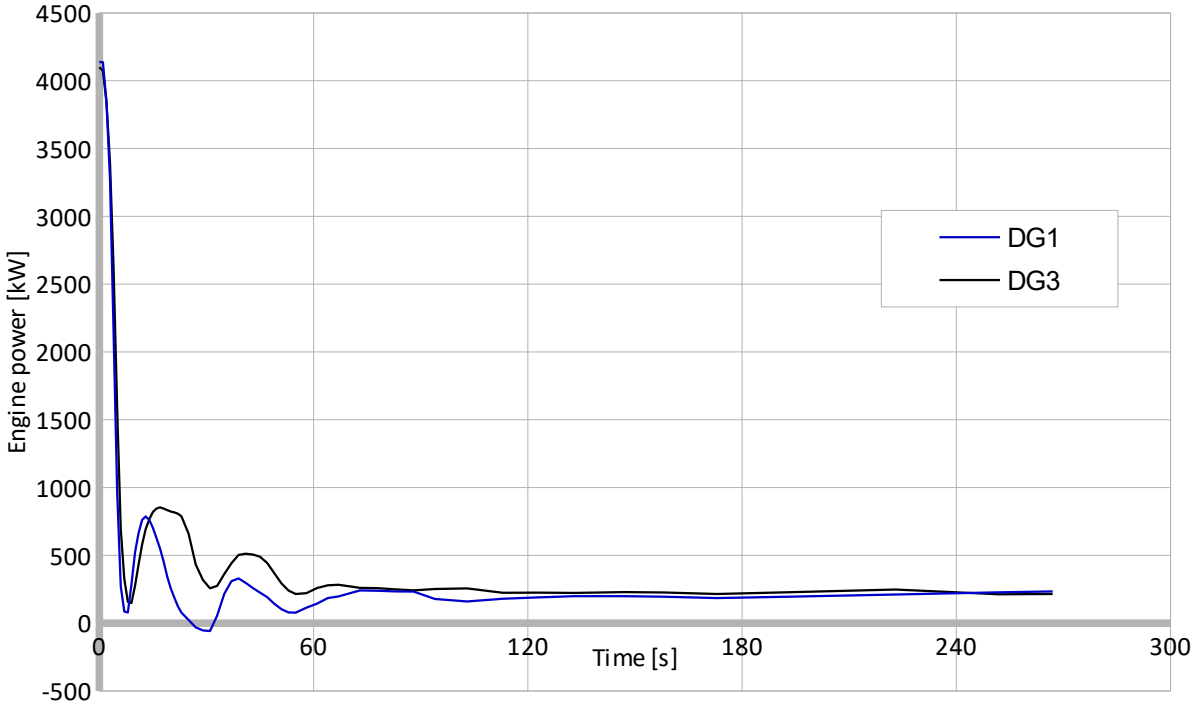

Star turn(1) 27.12.2014			
Wind direction [deg]	20	Initial speed [knots]	12
Wind speed [m/s]	4	Initial heading [deg]	336

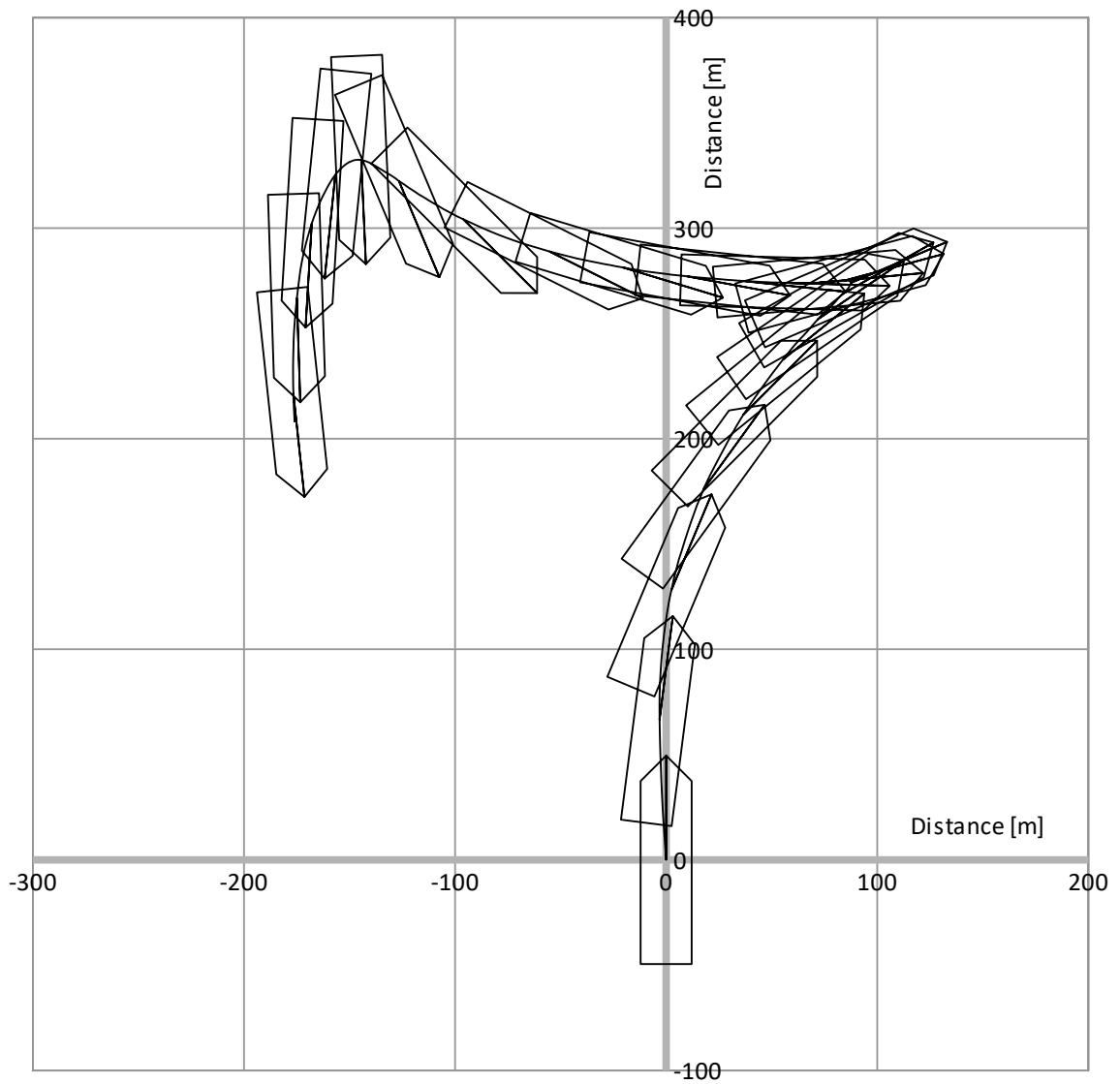

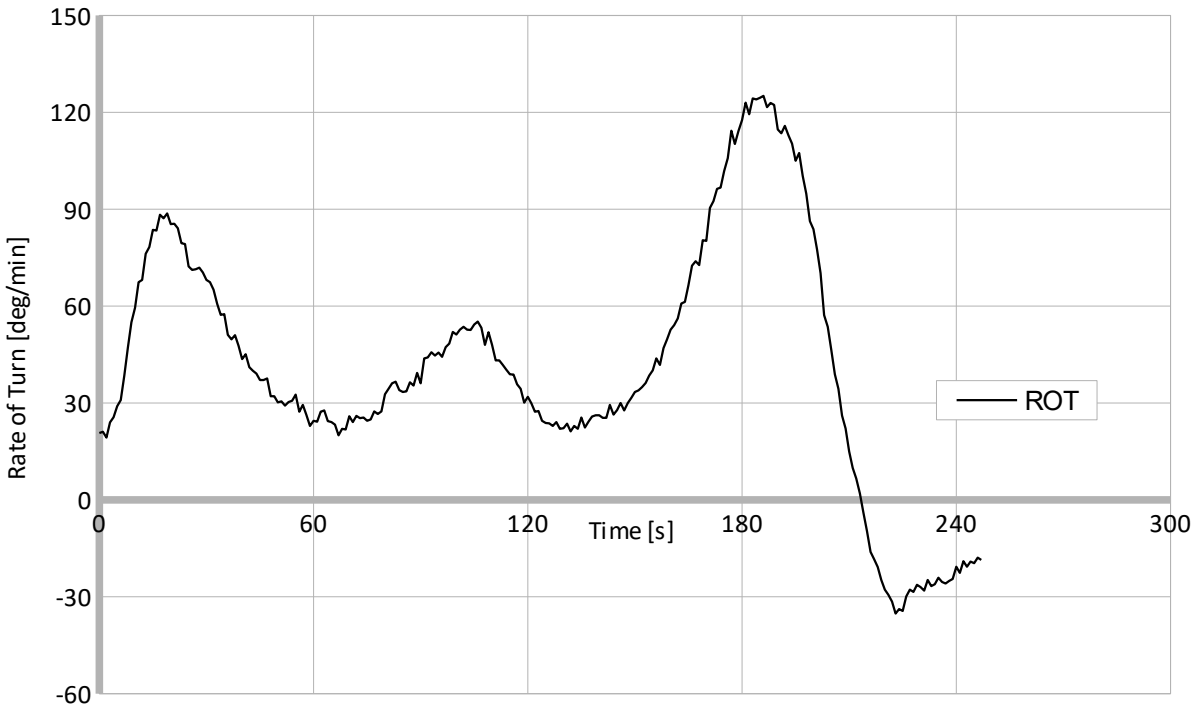
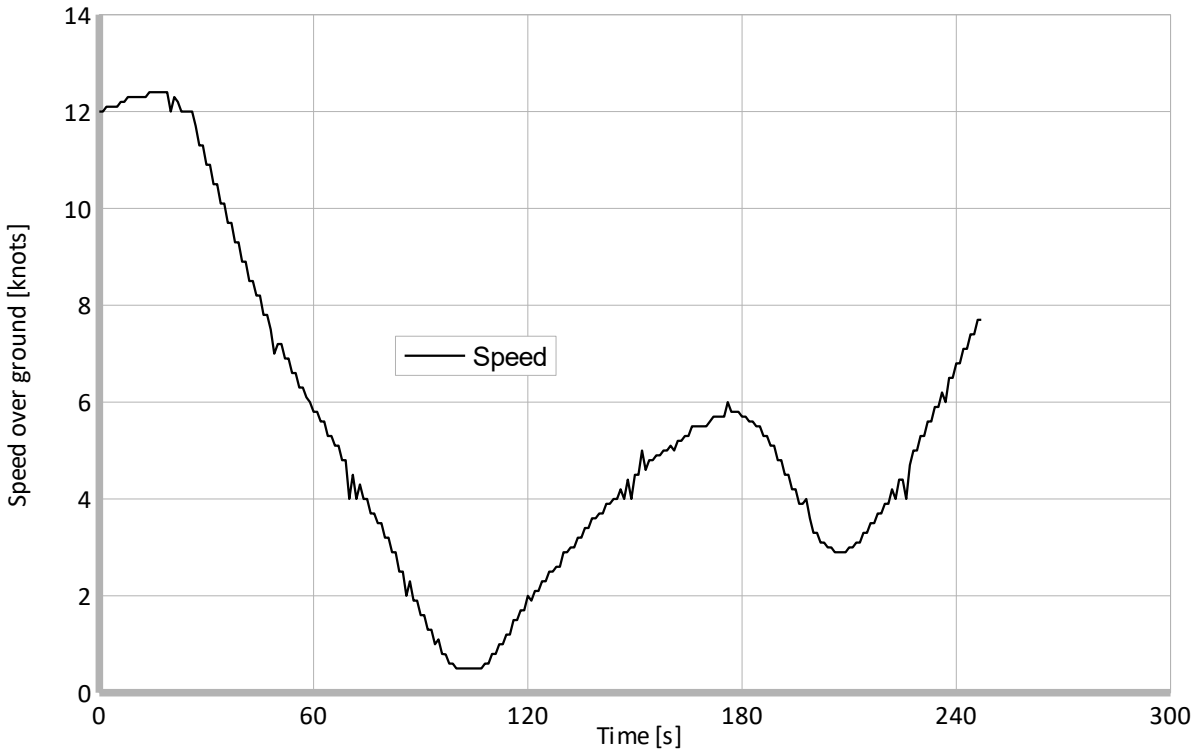

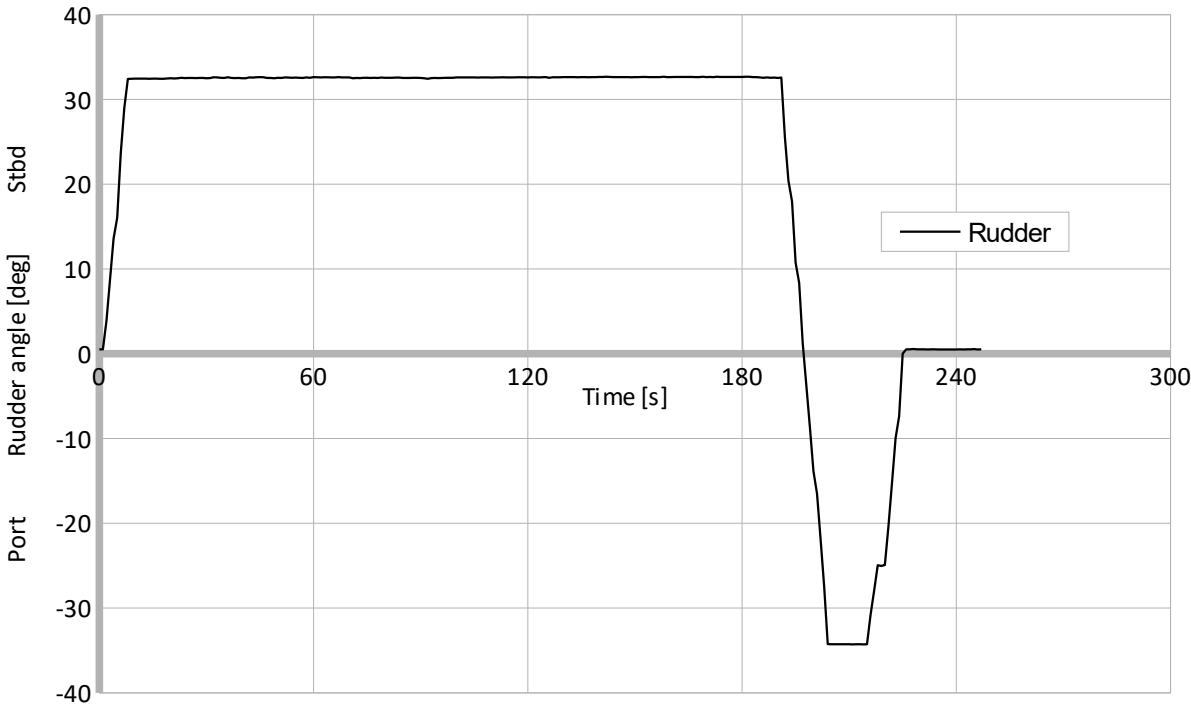
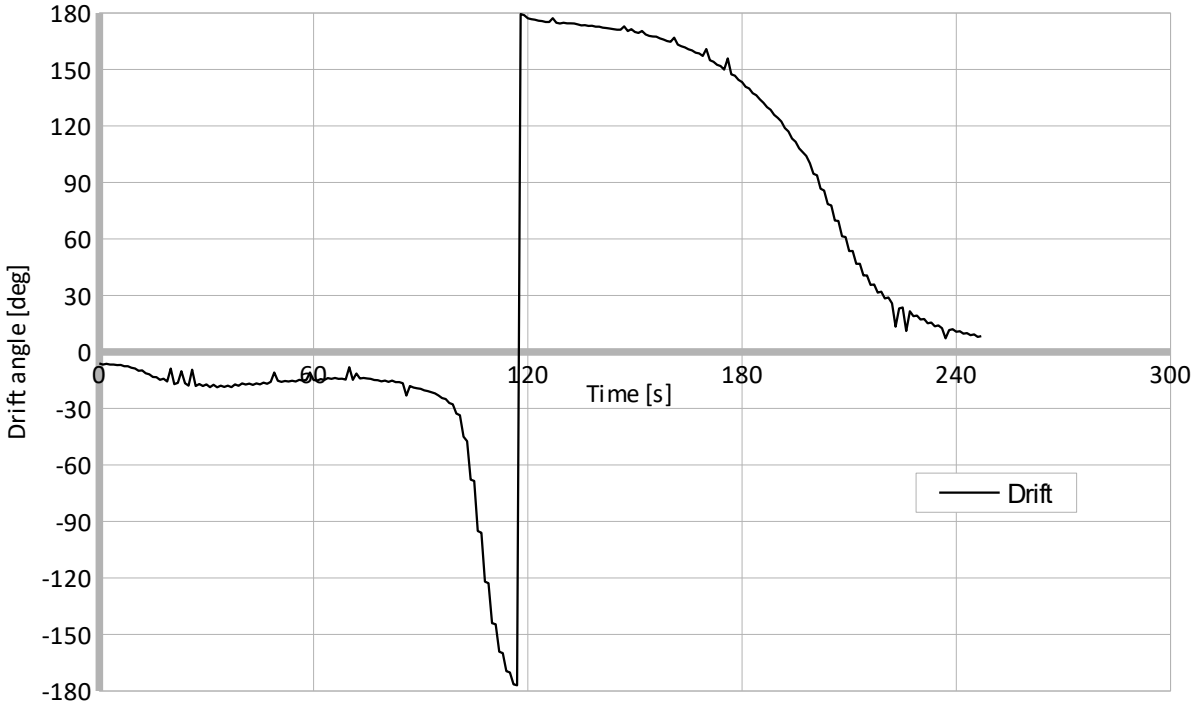

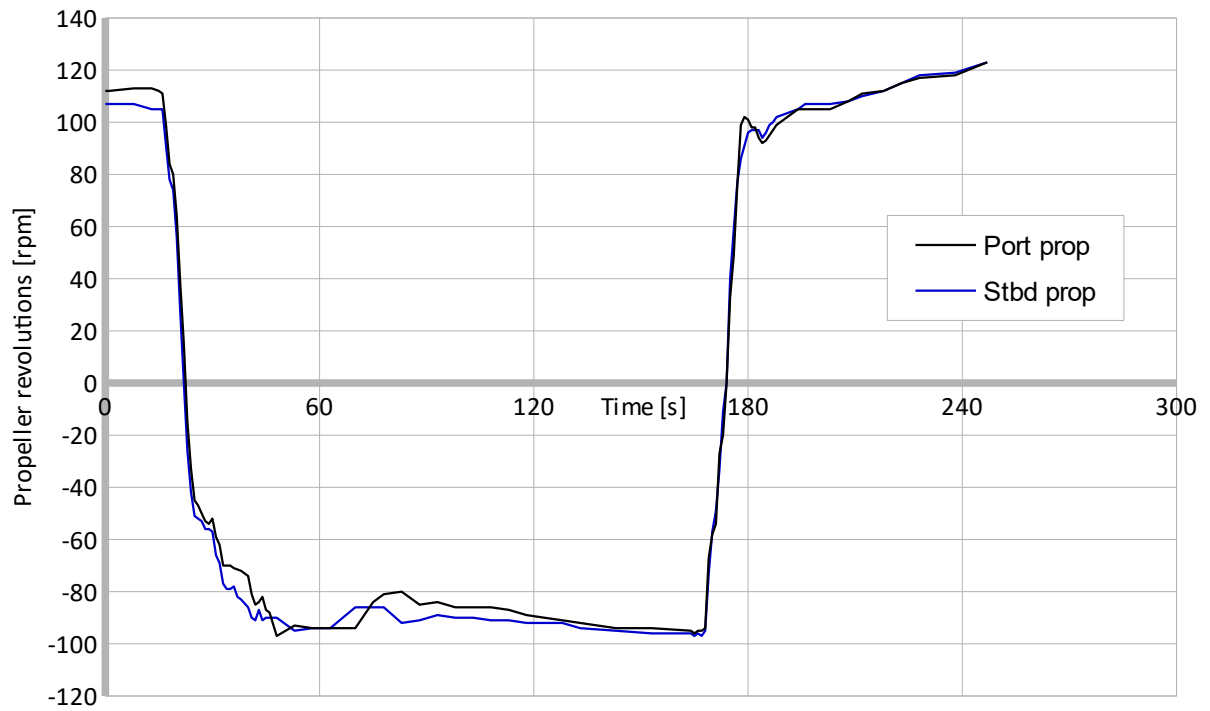

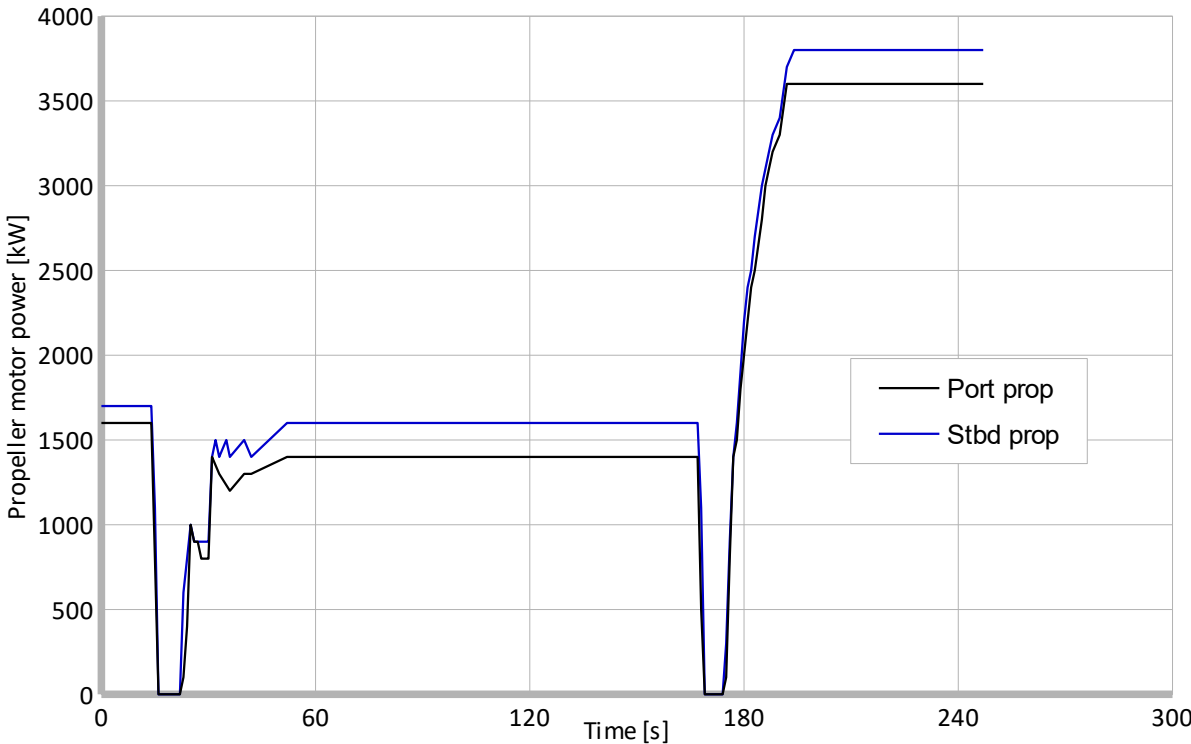
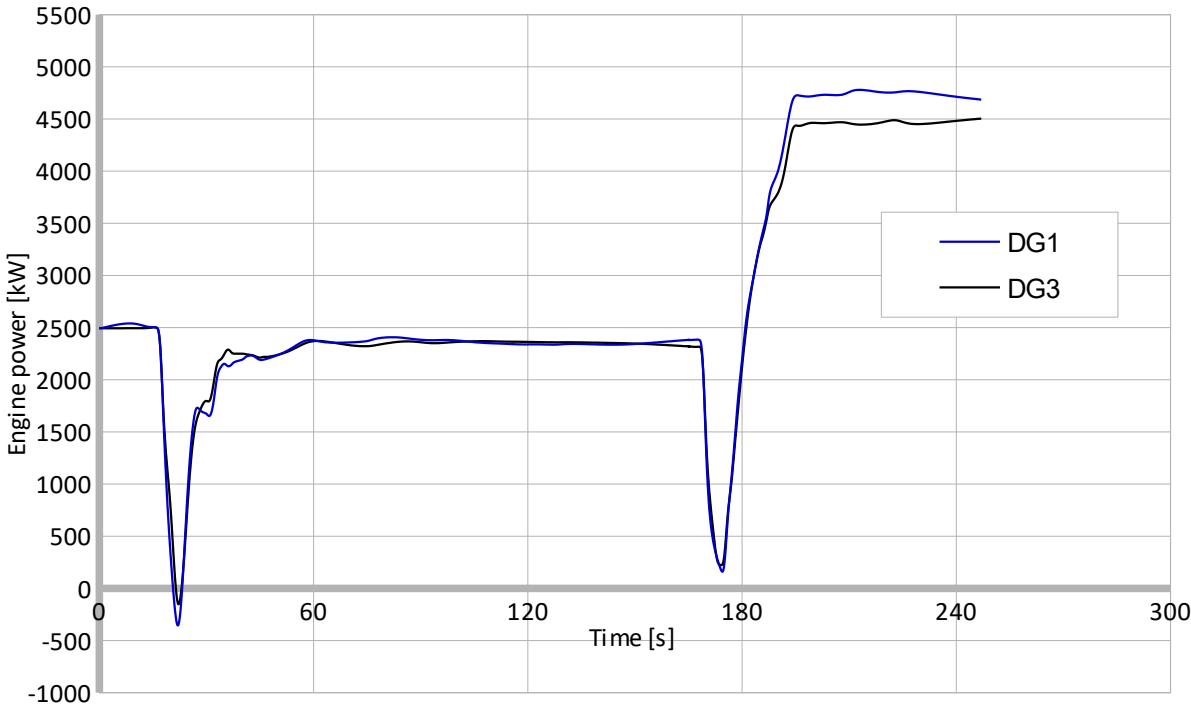

Star turn(2) 27.12.2014			
Wind direction [deg]	20	Initial speed [knots]	12,4
Wind speed [m/s]	4	Initial heading [deg]	190

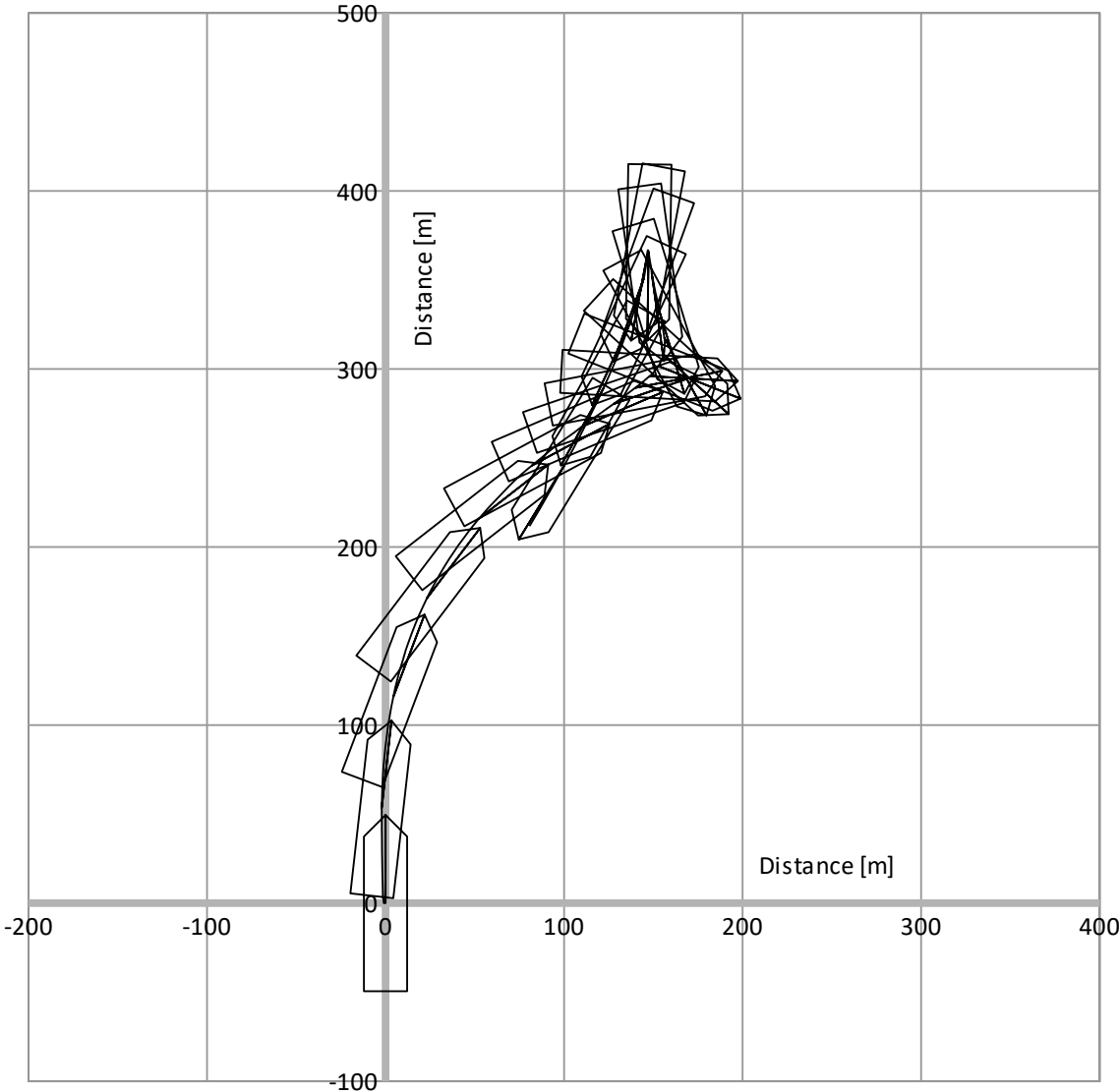

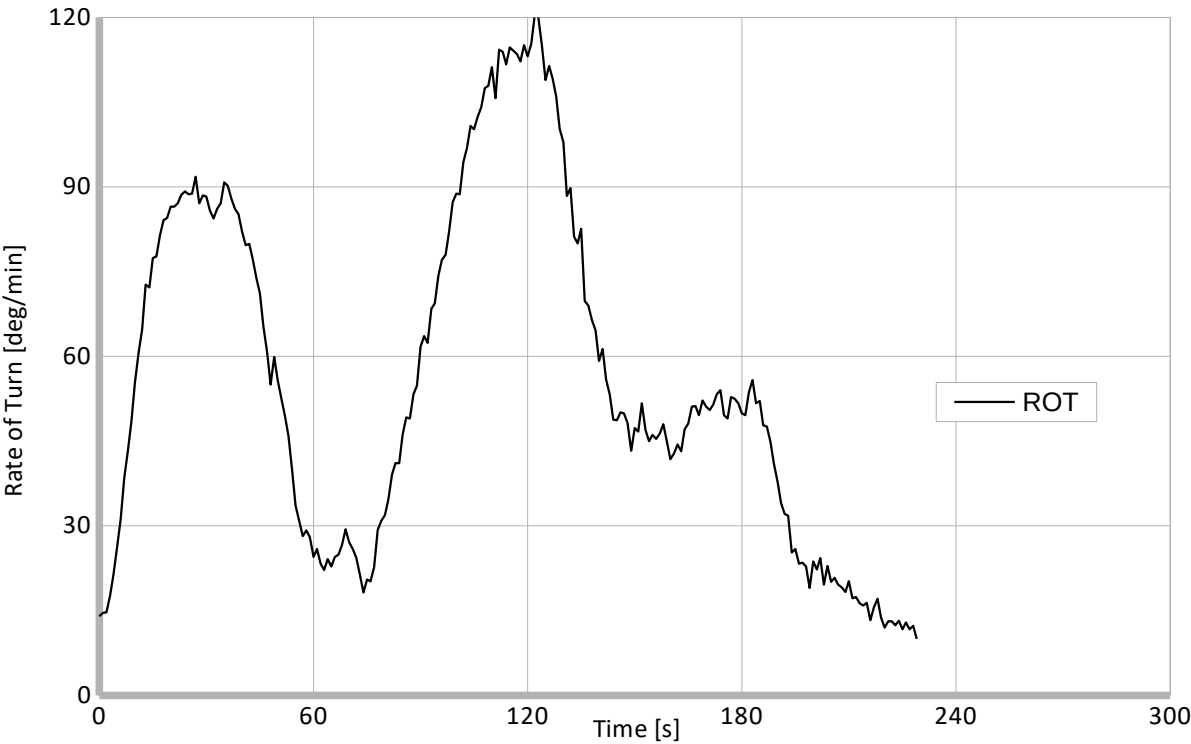
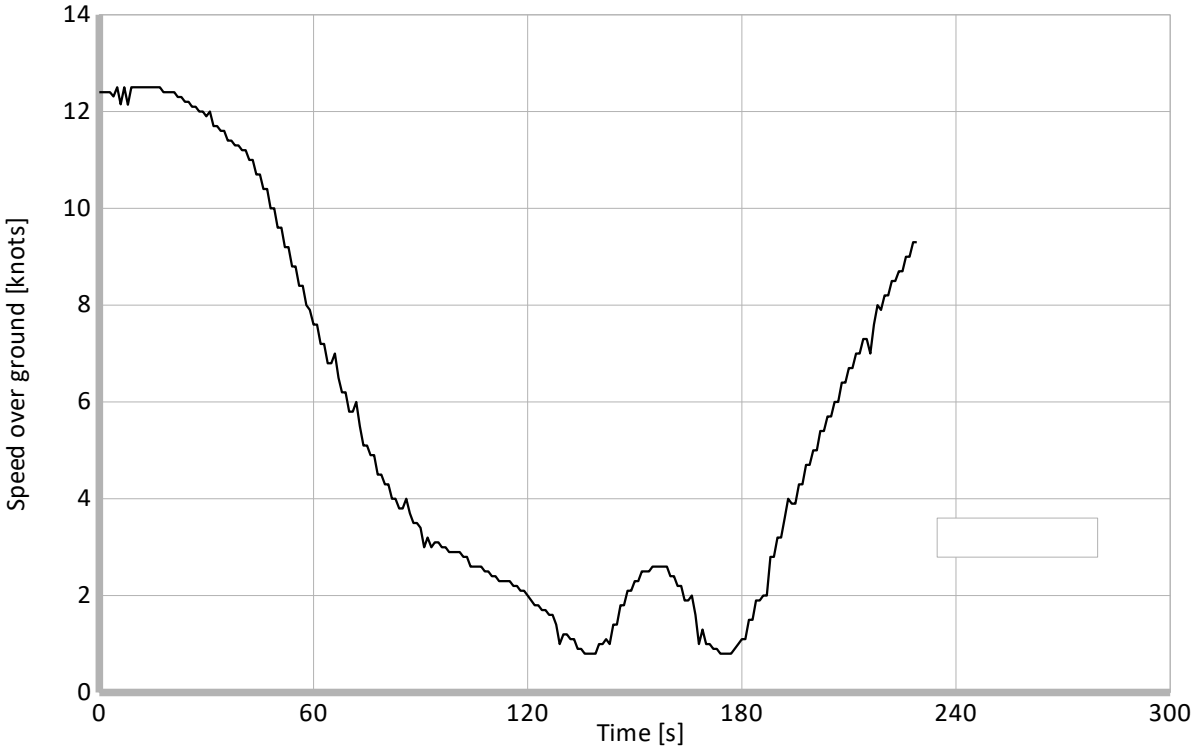

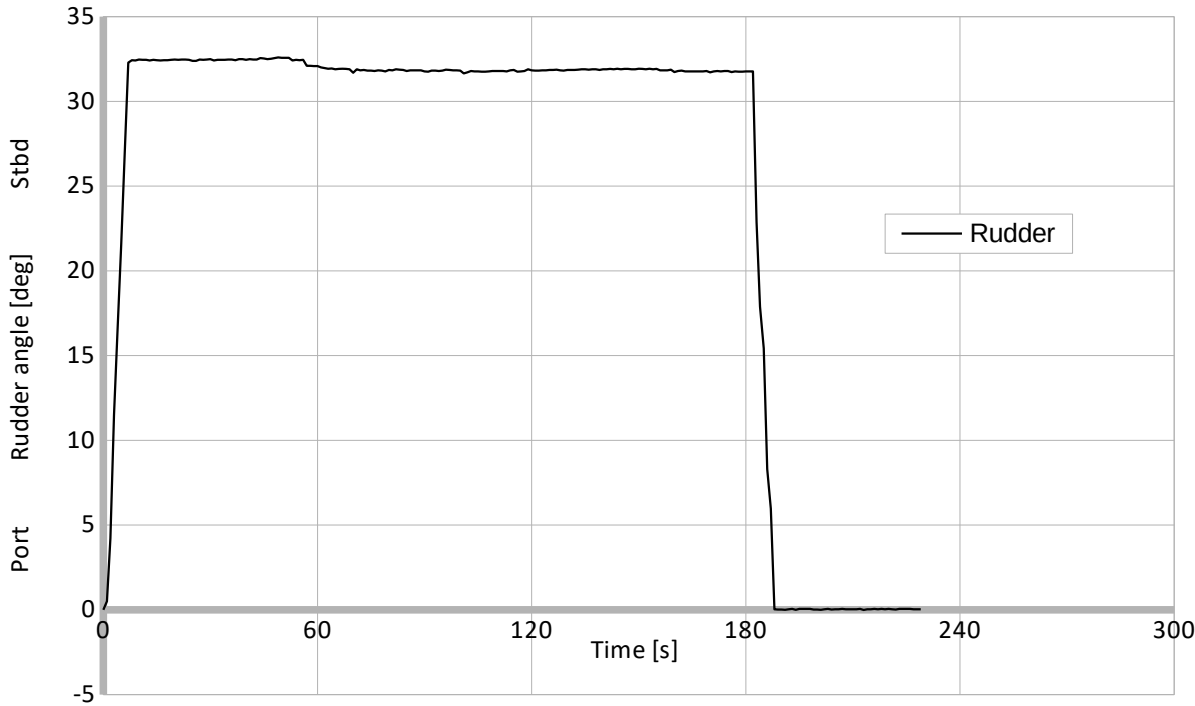
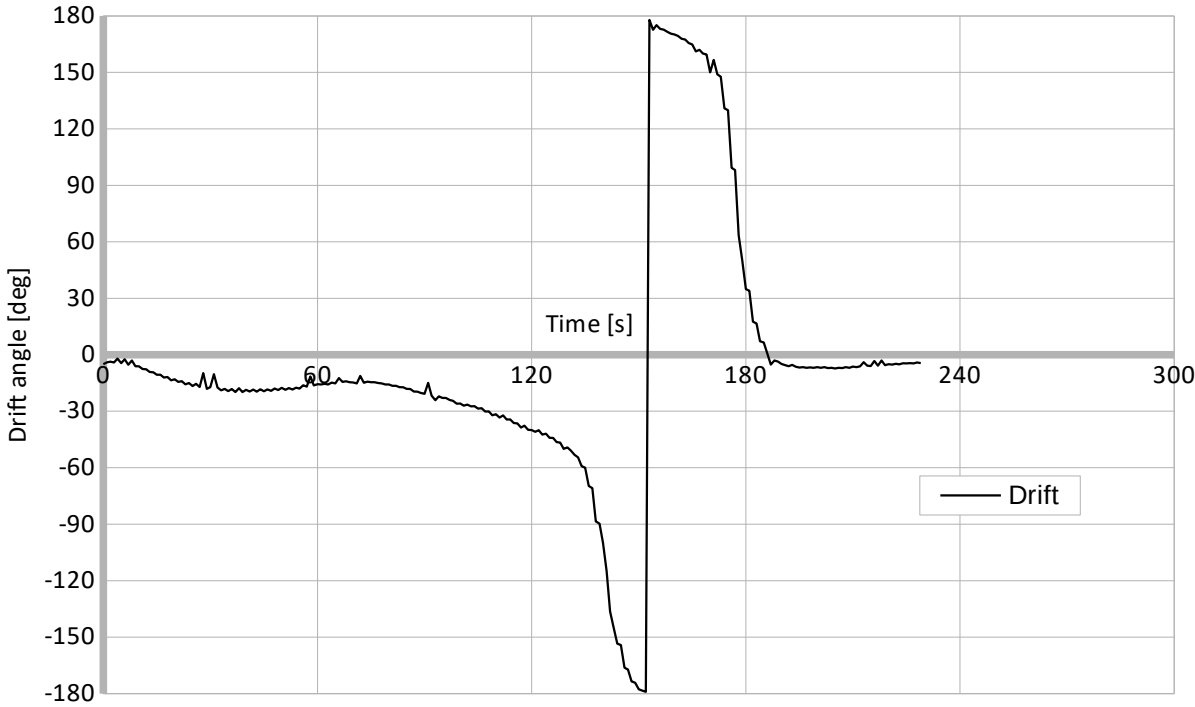

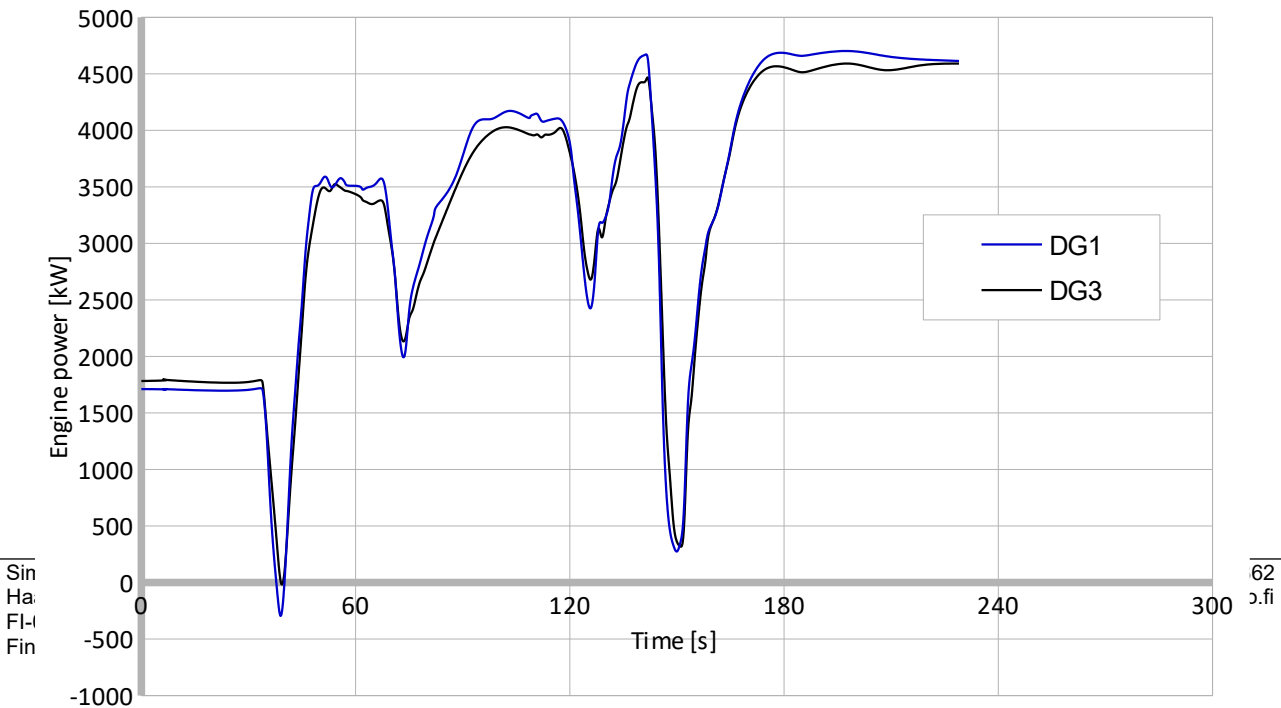
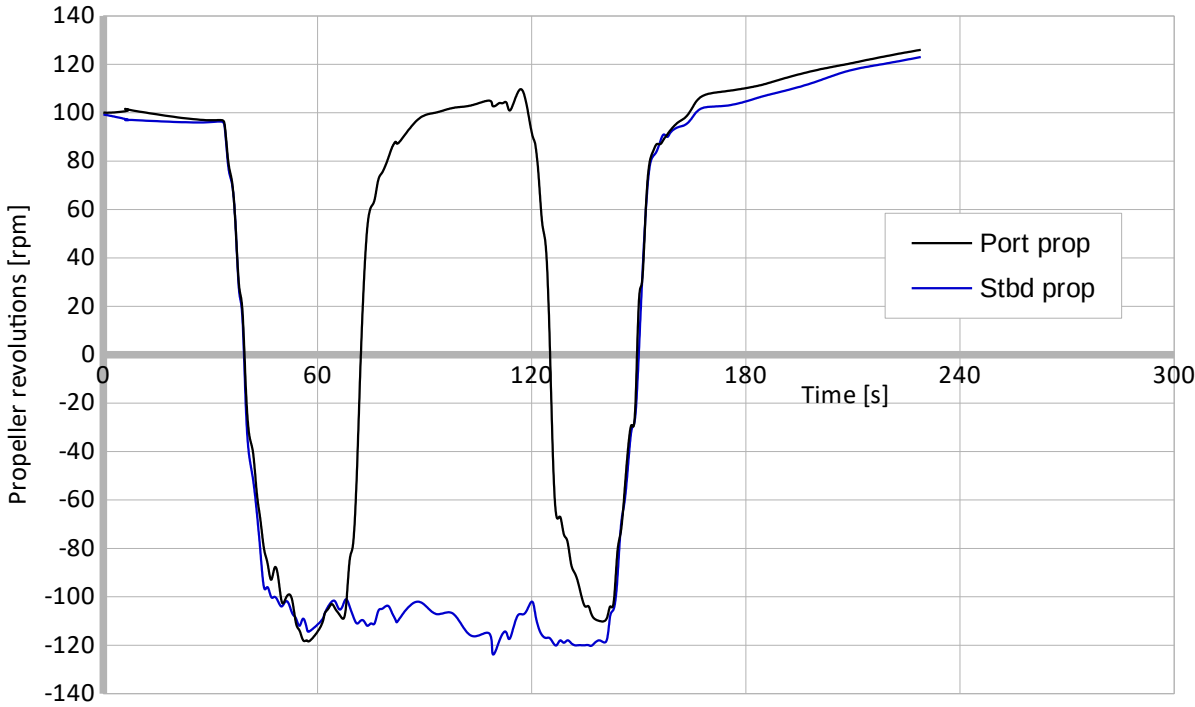

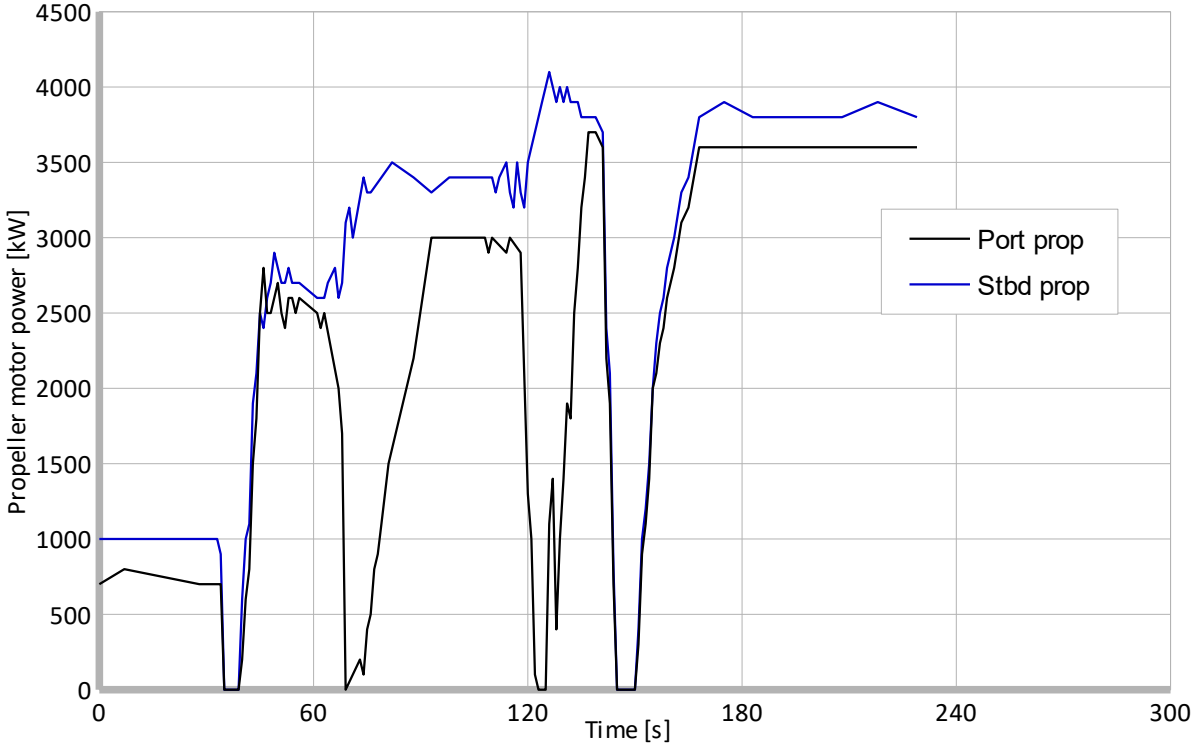

Star turn(3) 27.12.2014			
Wind direction [deg]	20	Initial speed [knots]	12,3
Wind speed [m/s]	4	Initial heading [deg]	40

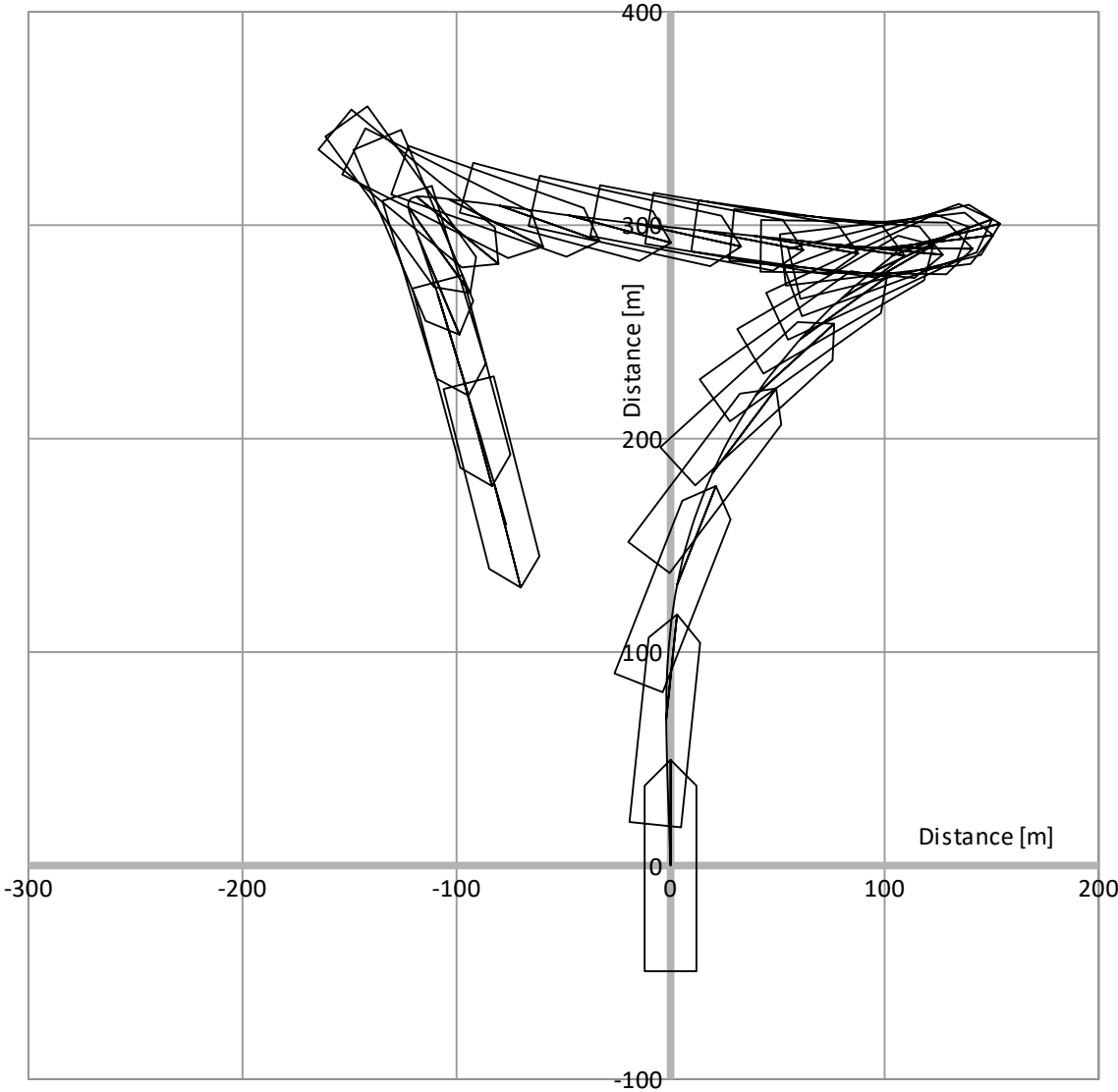

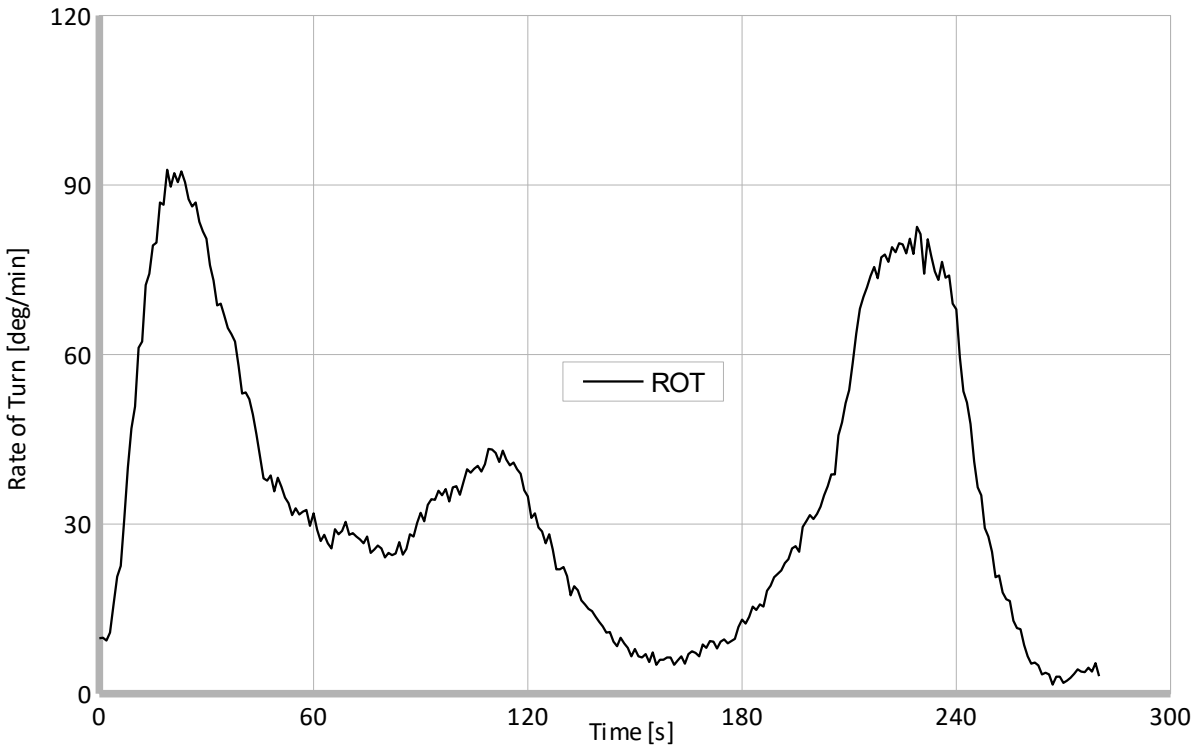
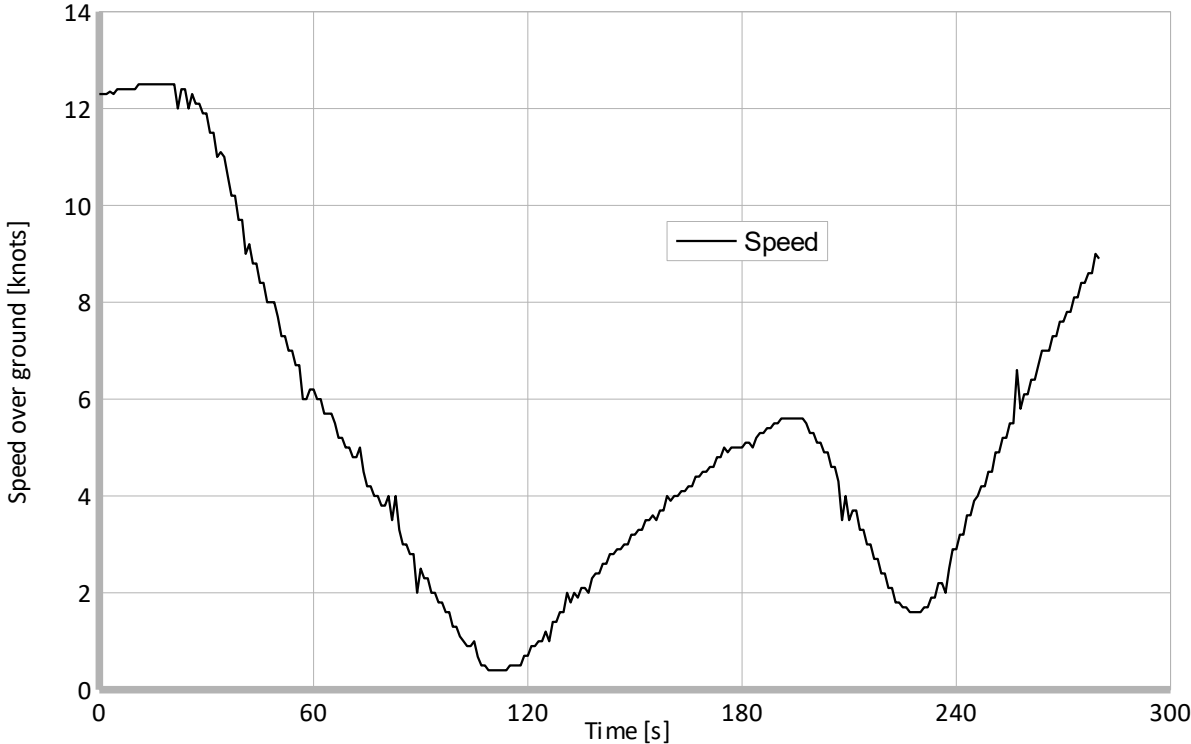

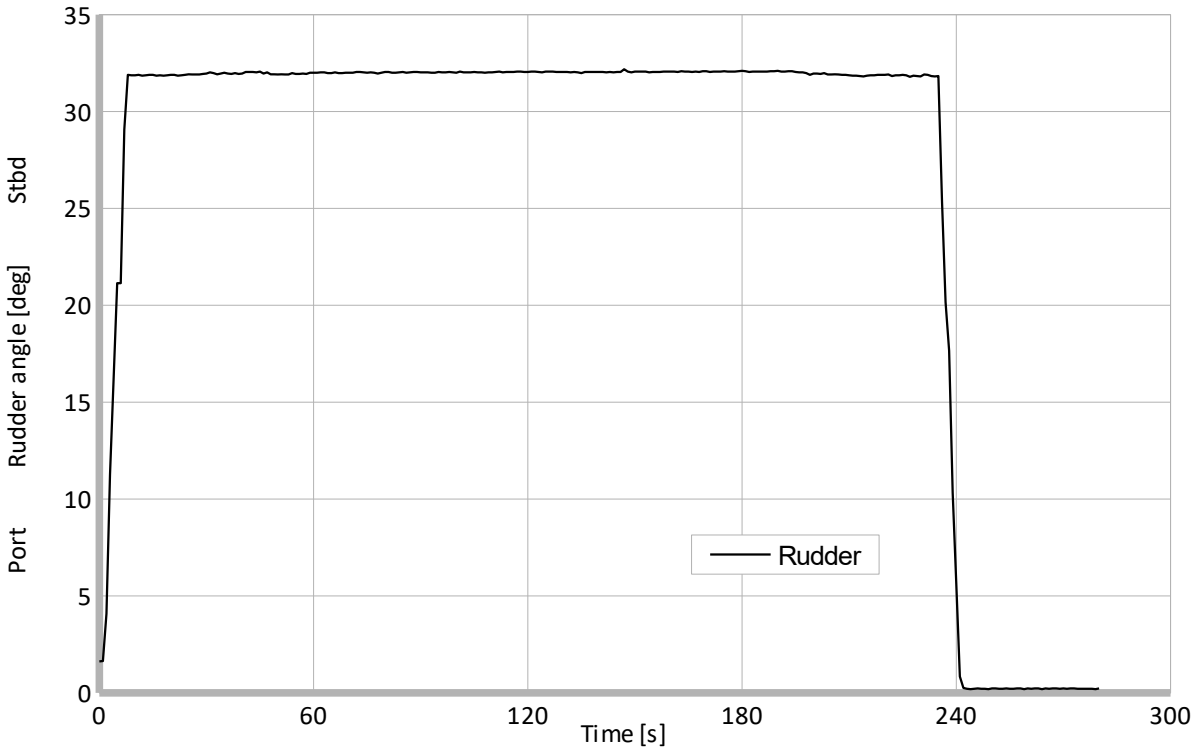
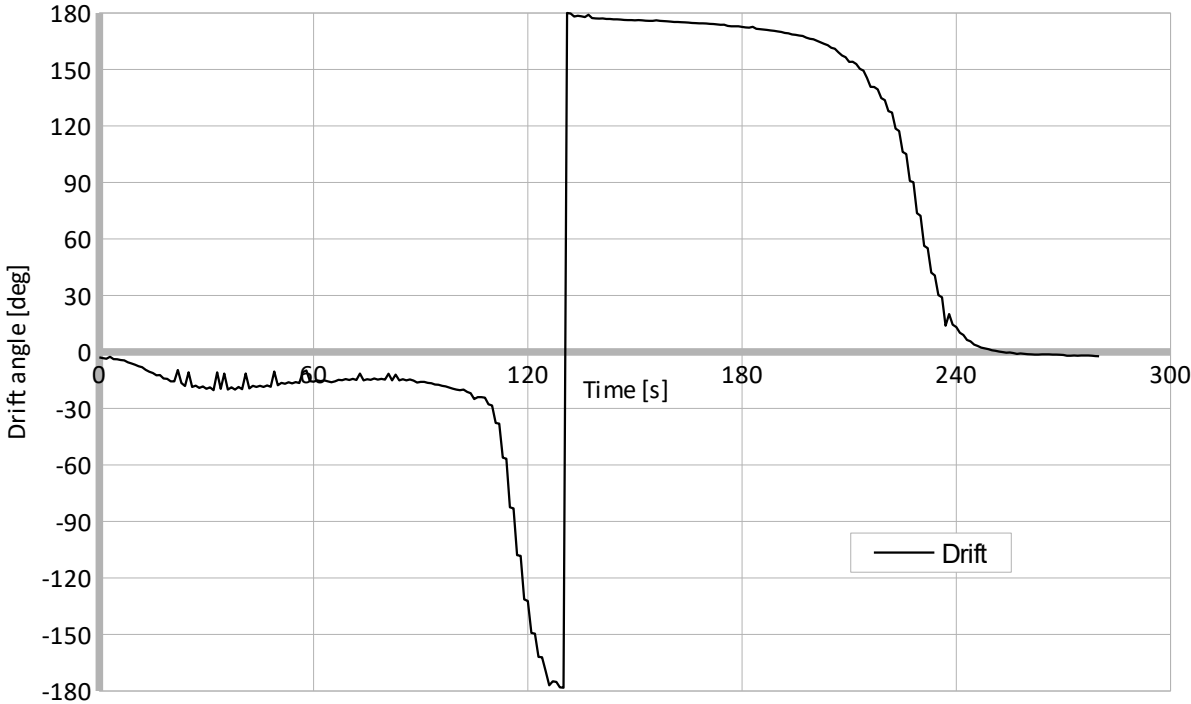

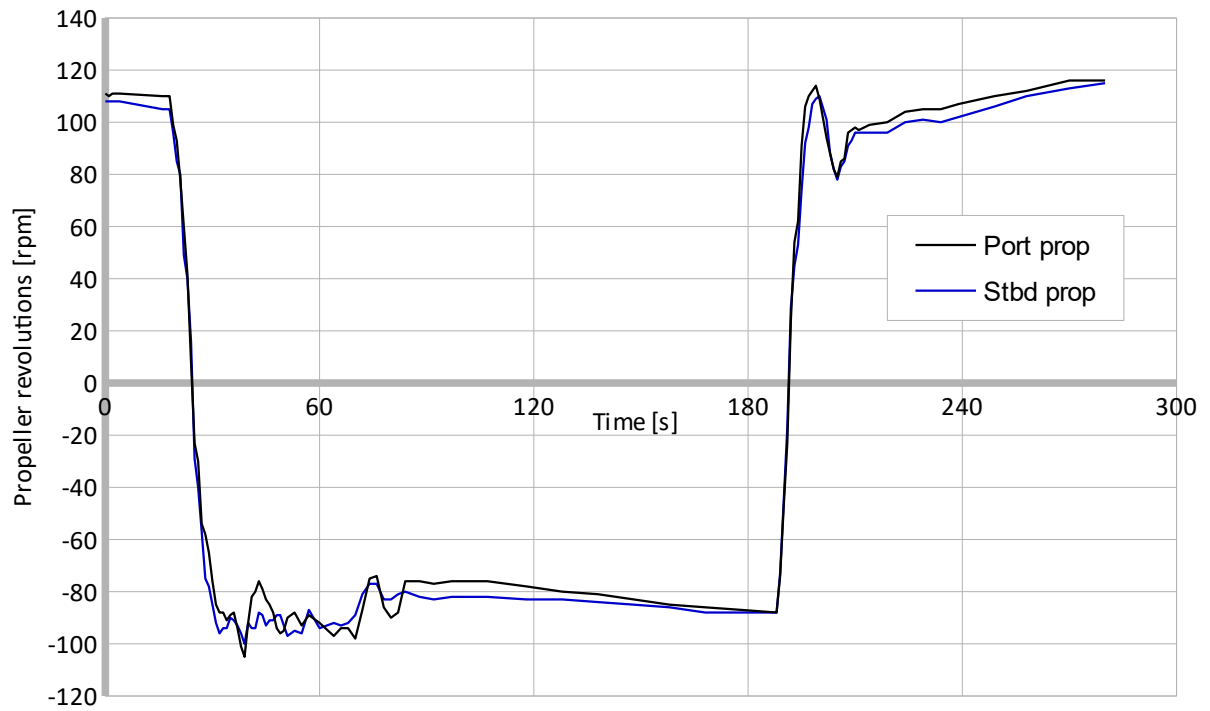

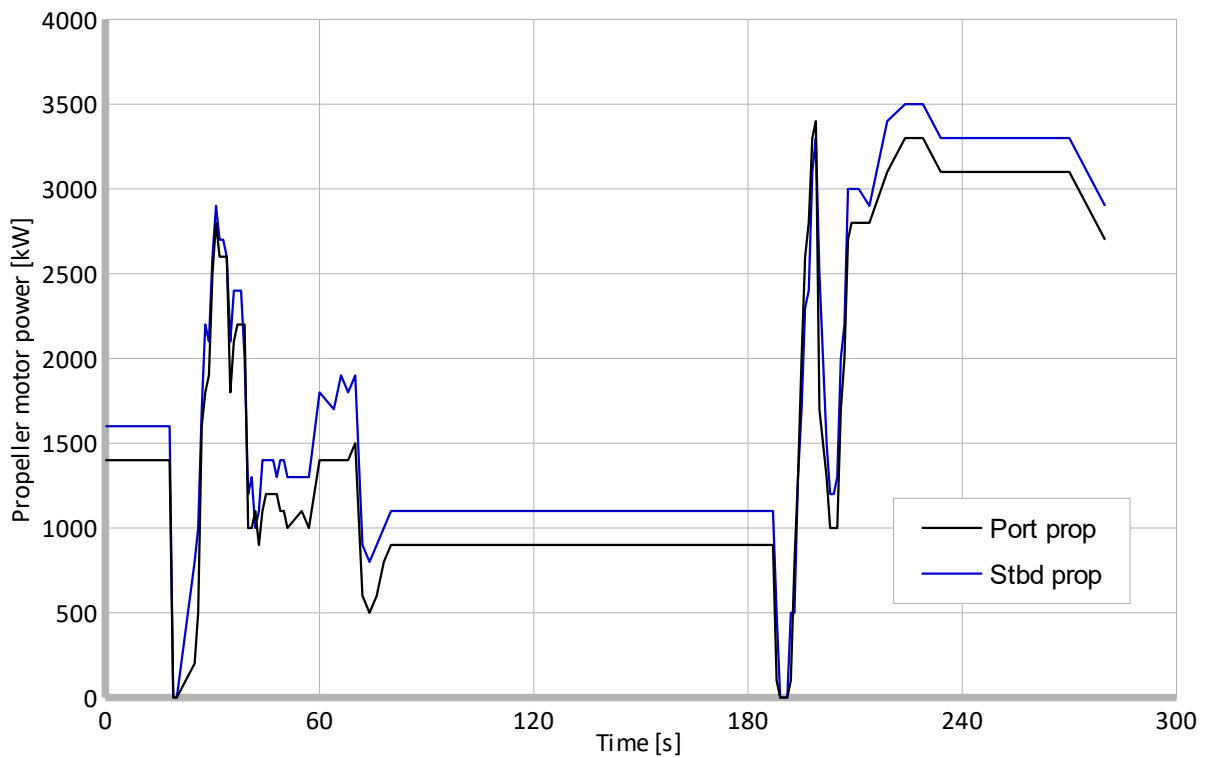
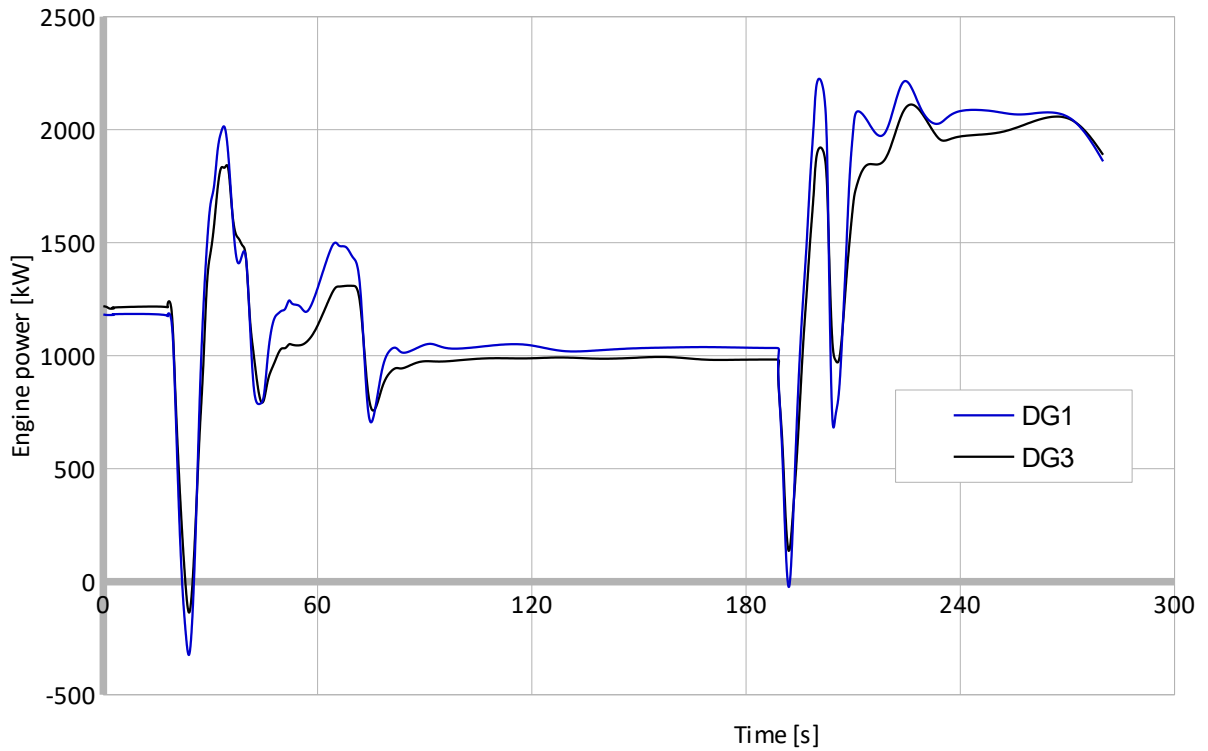

Acceleration test with 1+1 diesel generators

27.12.2014

Wind direction [deg]	20	Initial heading [deg]	355
Wind speed [m/s]	4	Time to reach 10 knots [s]	76
Initial speed [knots]	0,2	Time to reach 14 knots [s]	124

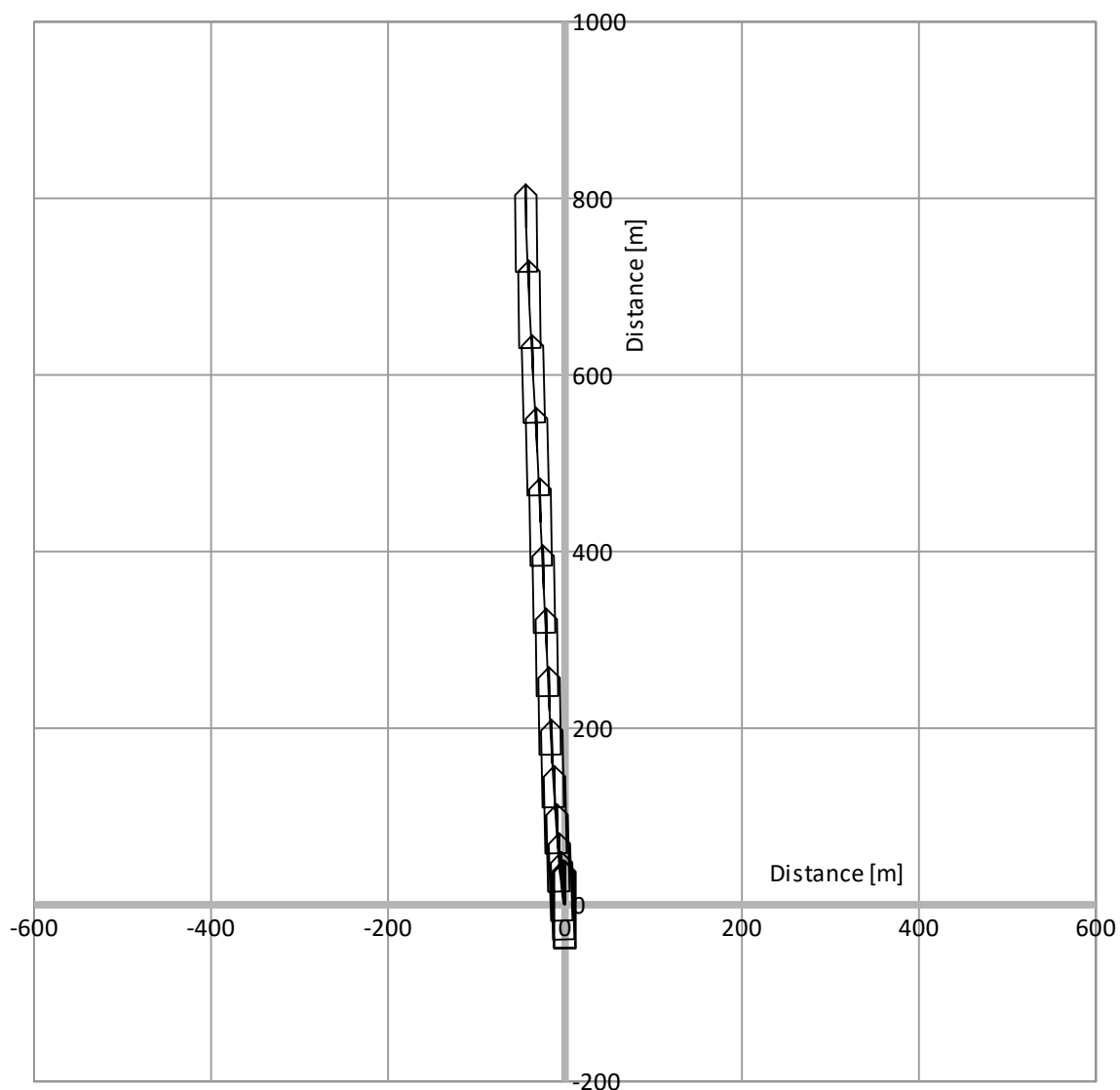

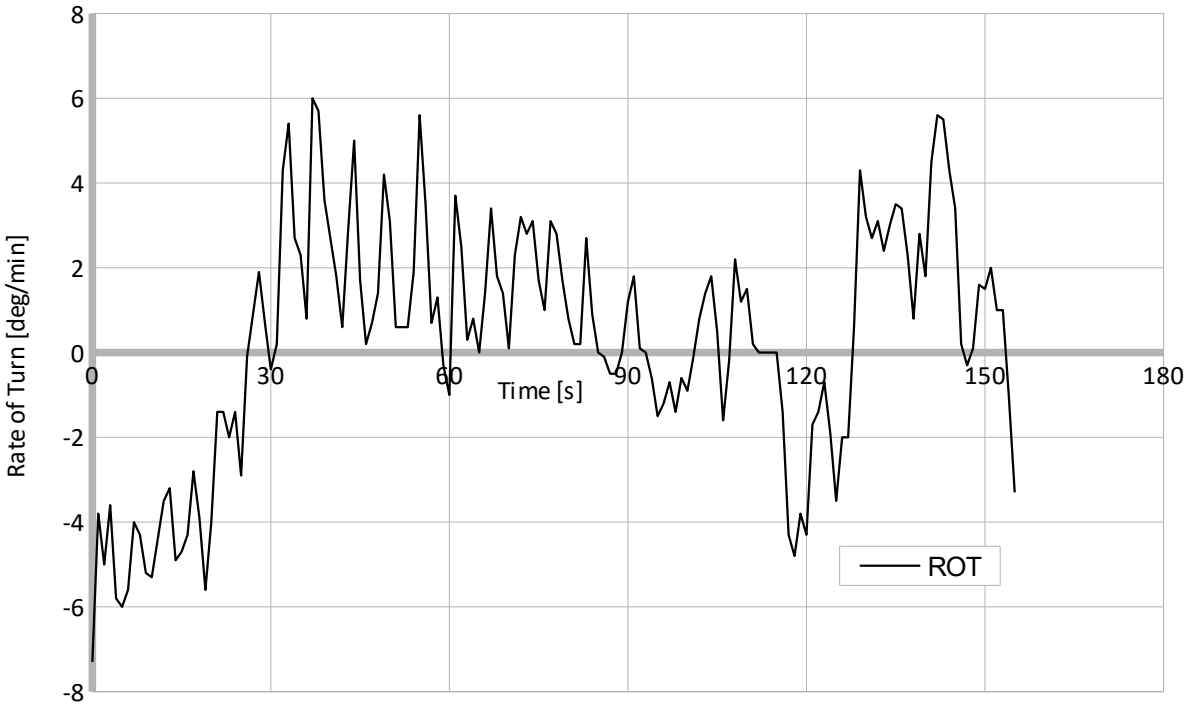
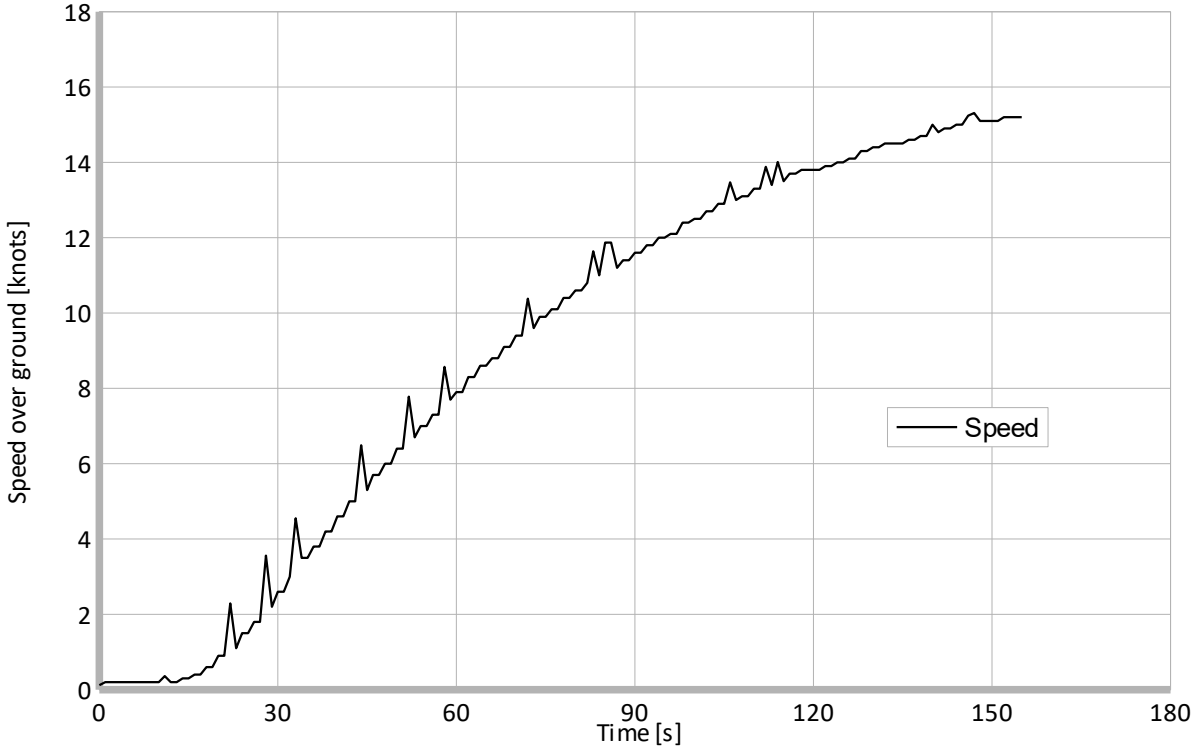

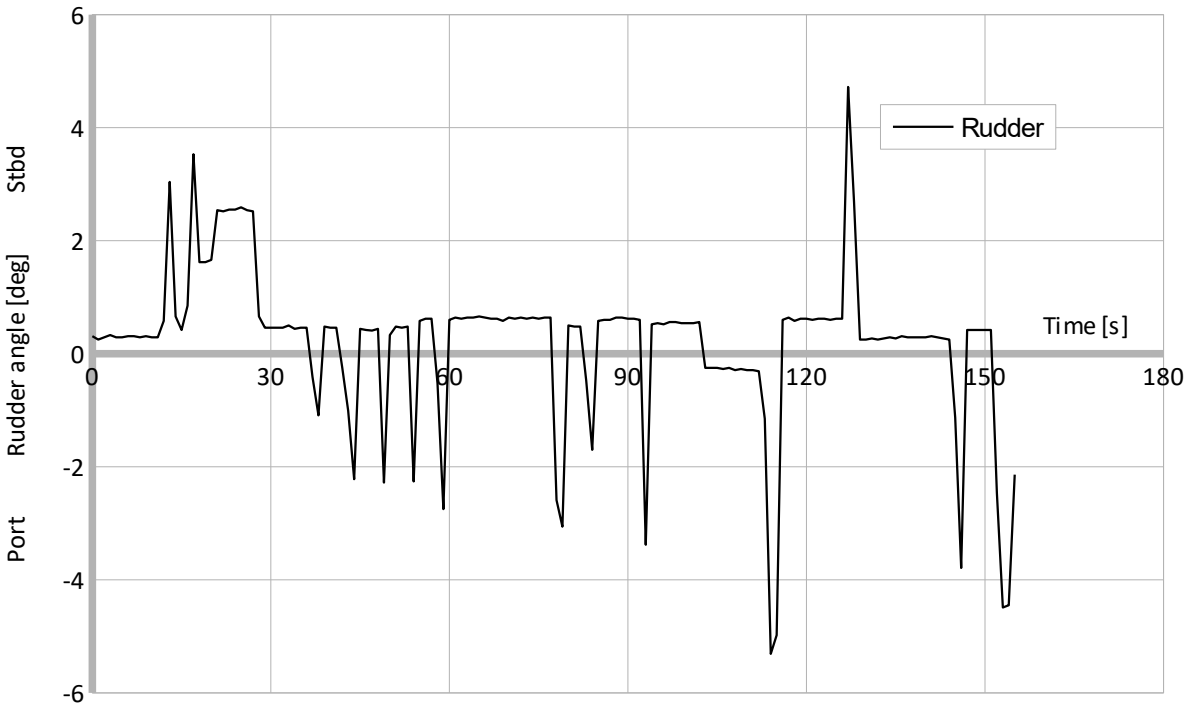
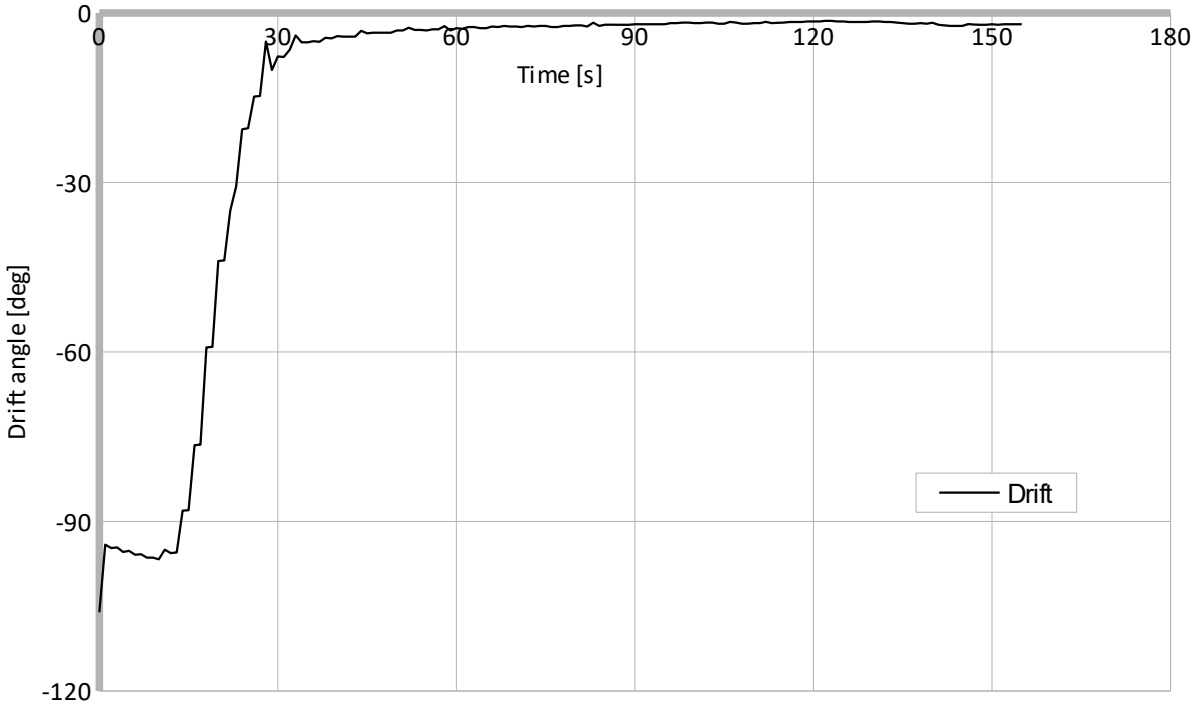

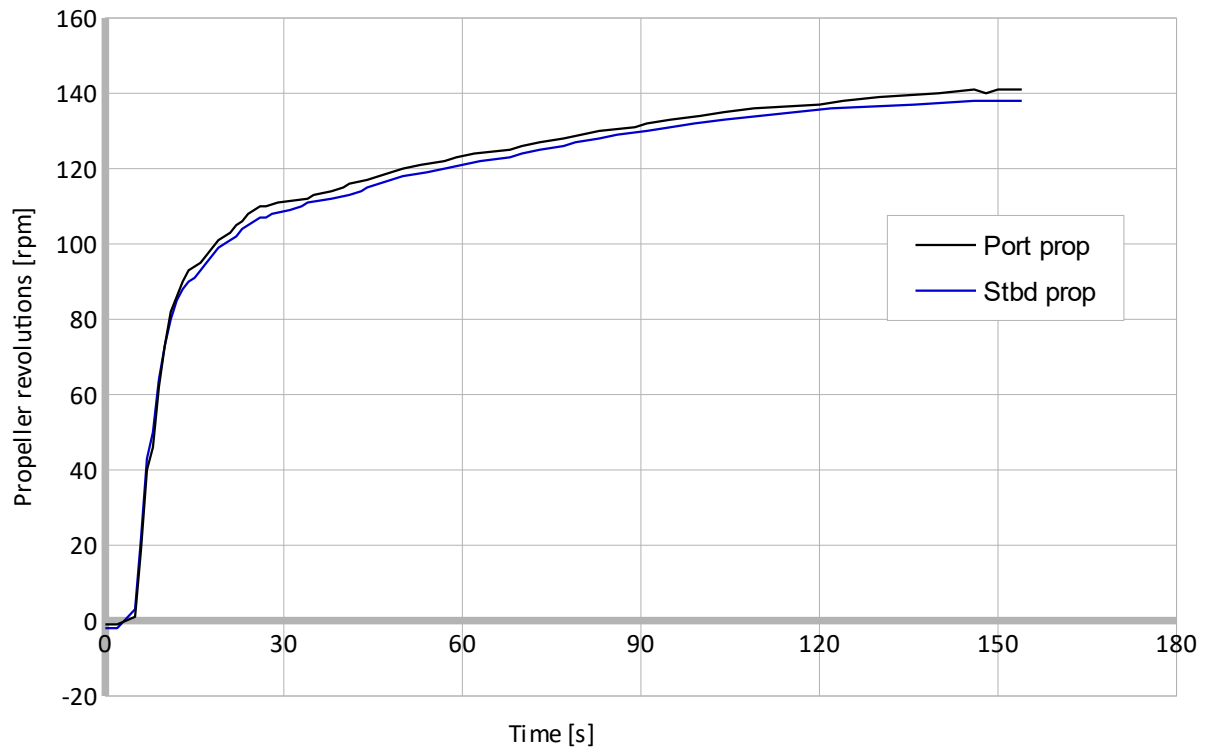

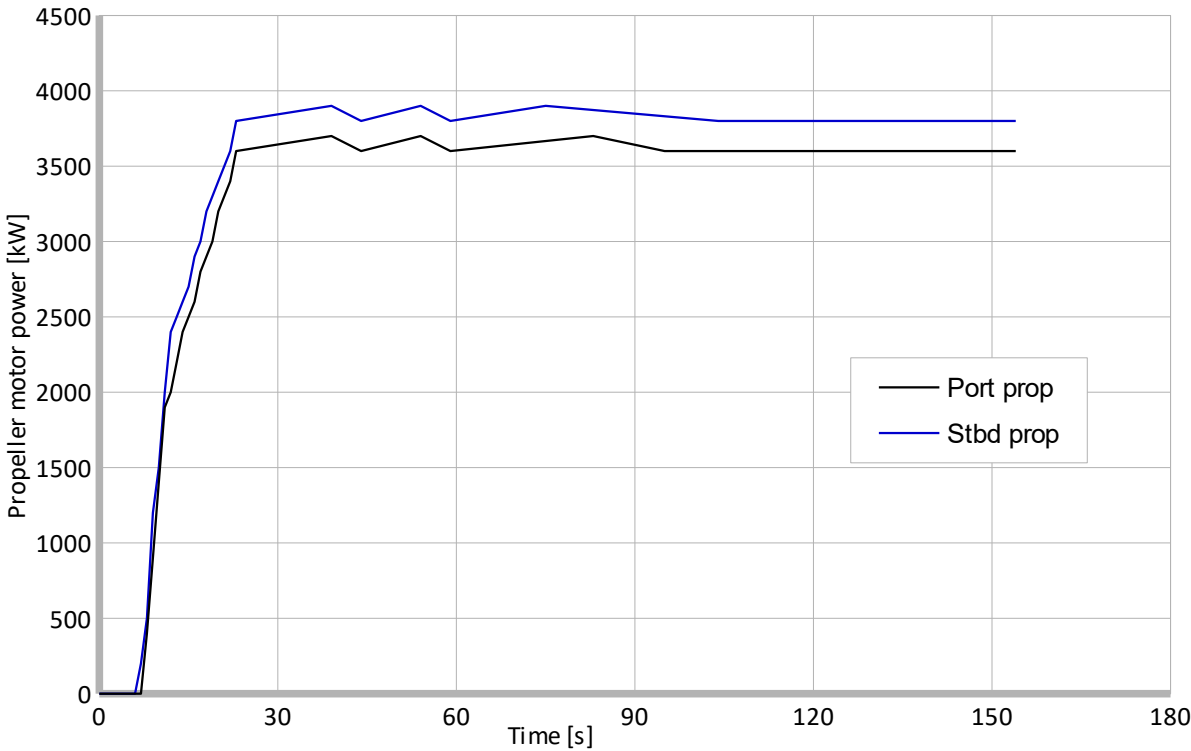
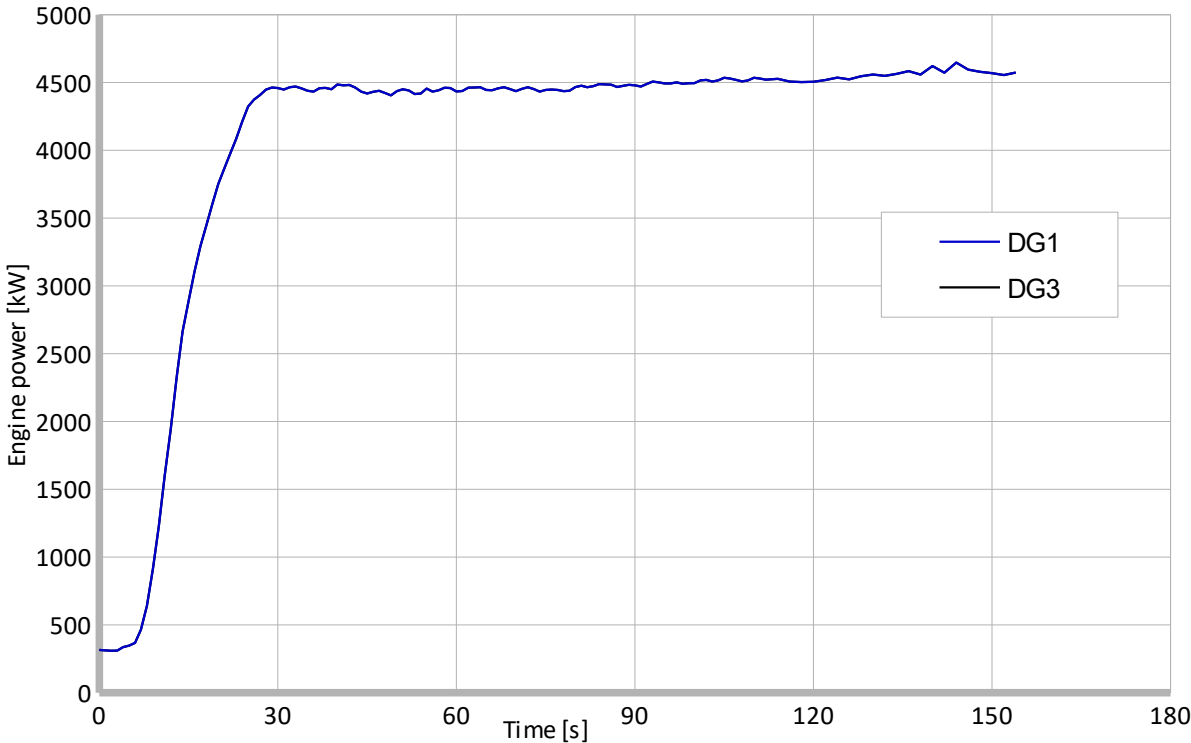

Deceleration test with 1+1 diesel generators

27.12.2014

Wind direction [deg]	20	Initial heading [deg]	355
Wind speed [m/s]	4	Initial speed [knots]	15,4

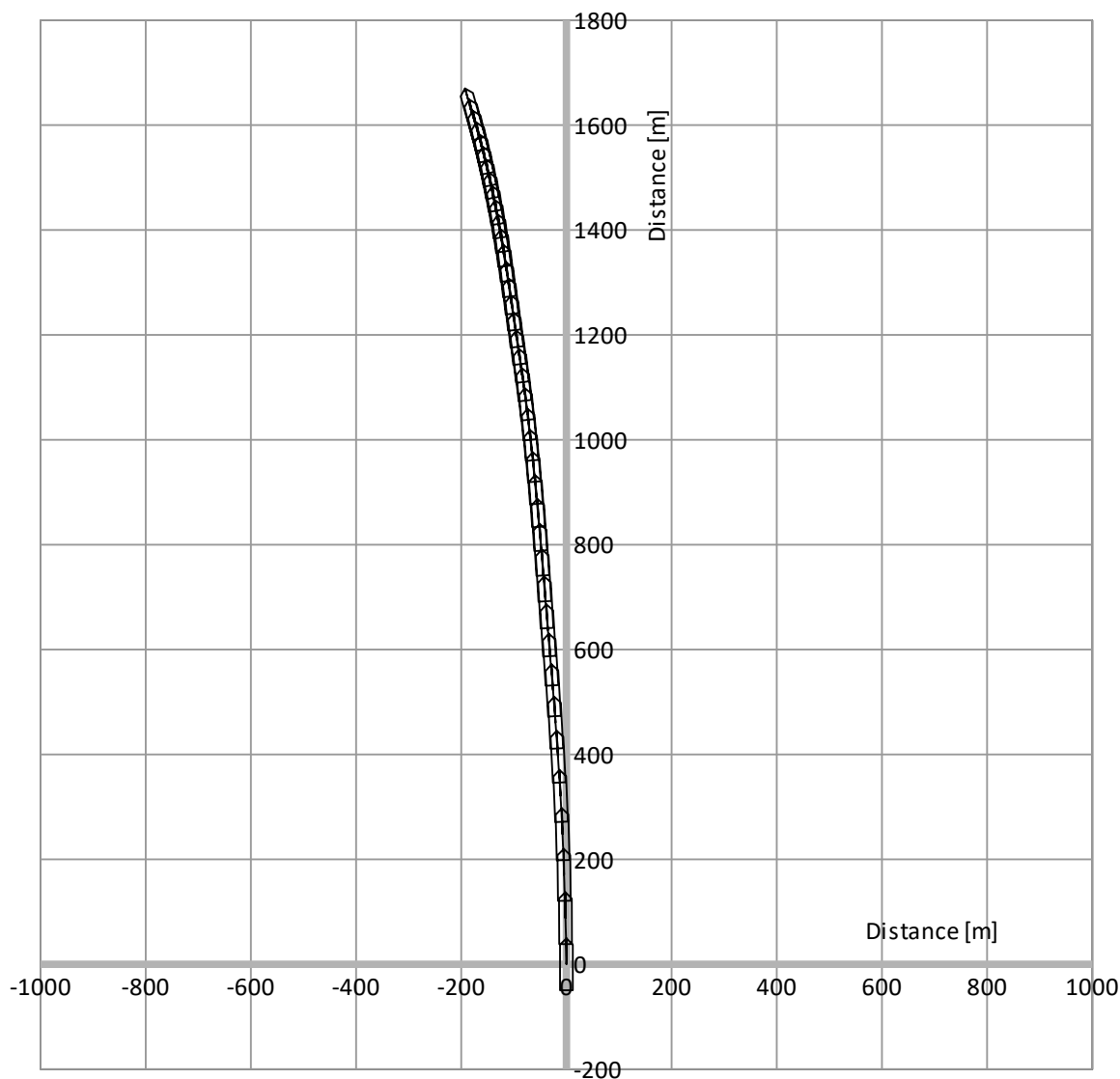

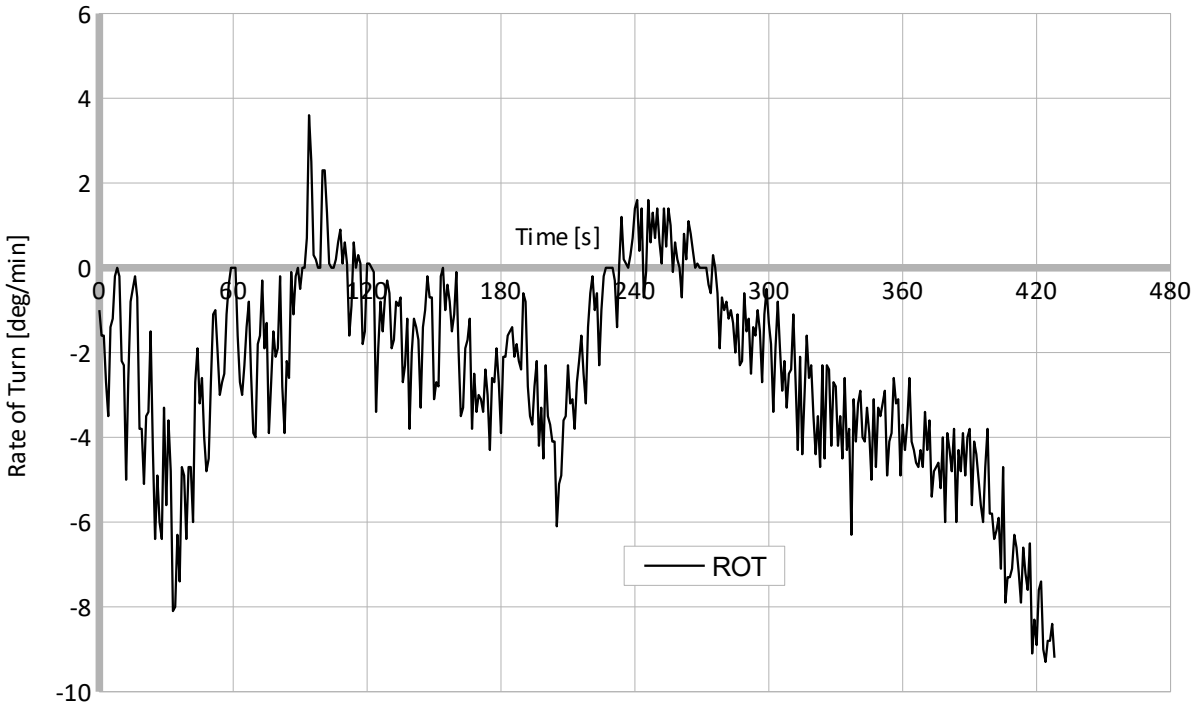
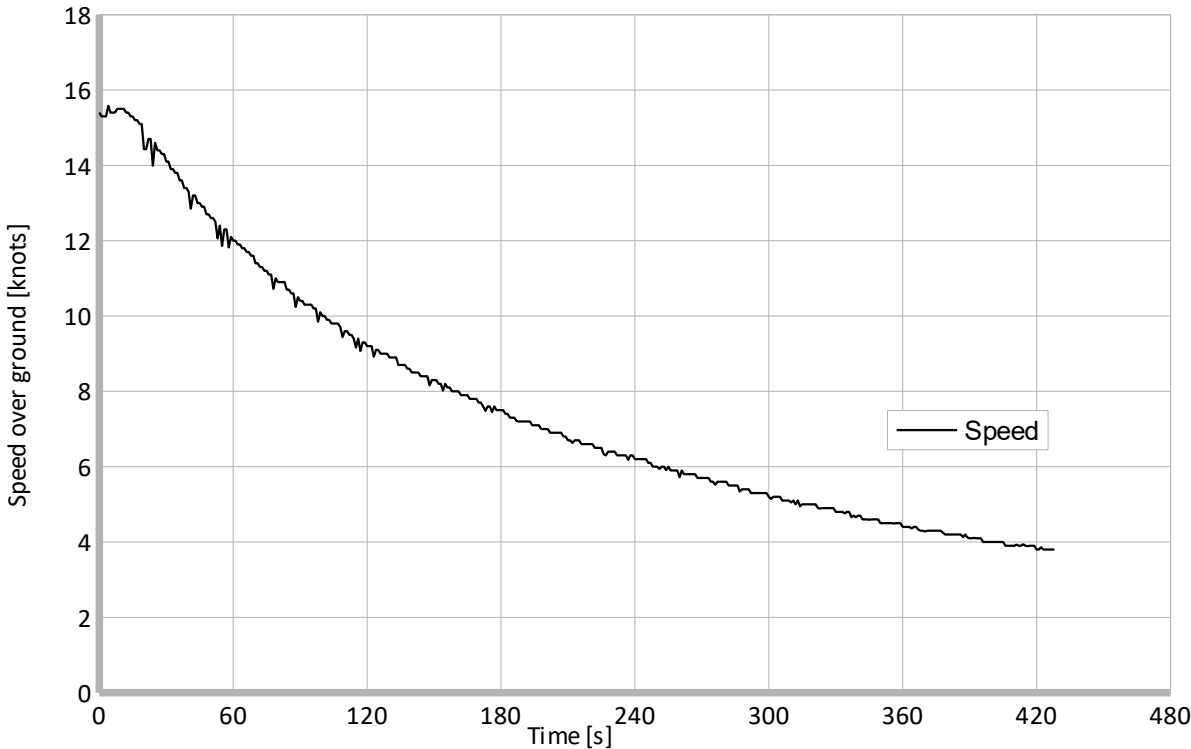

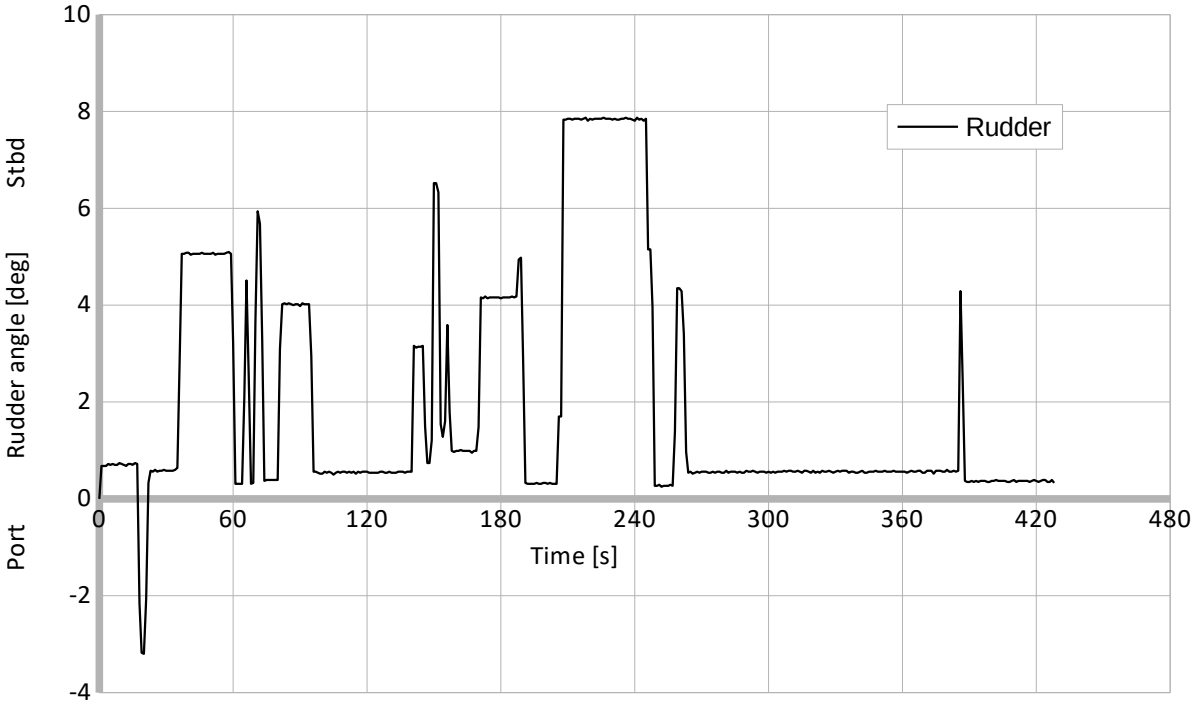
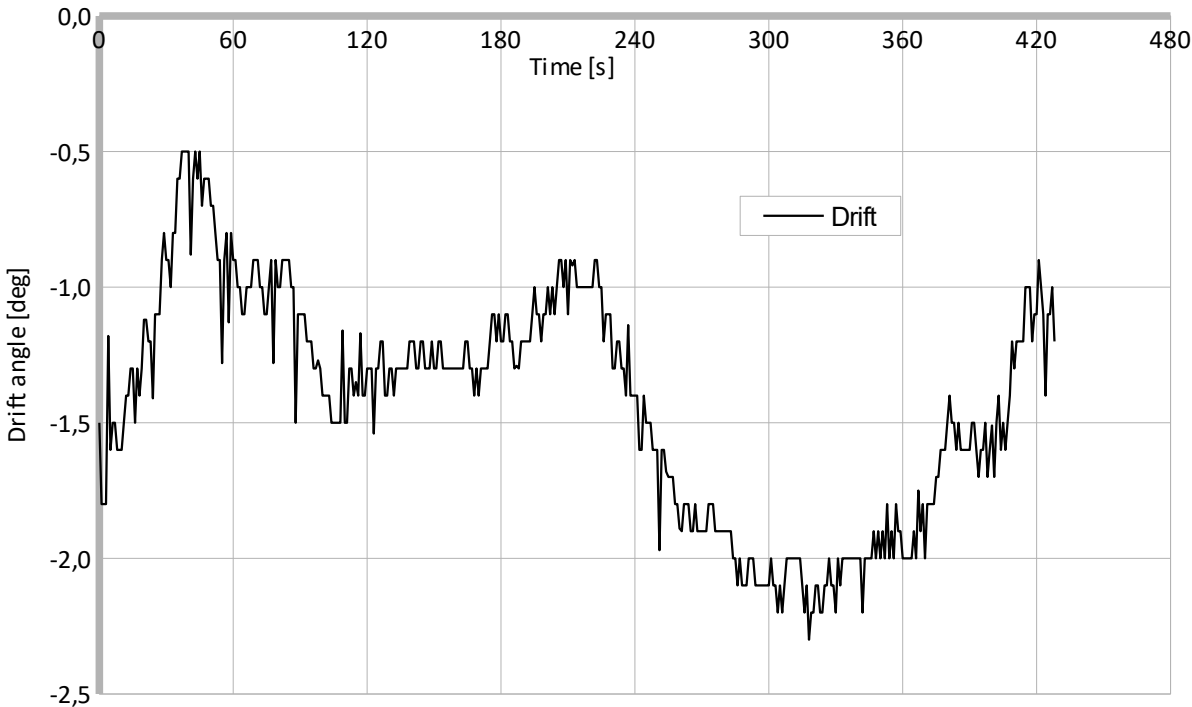

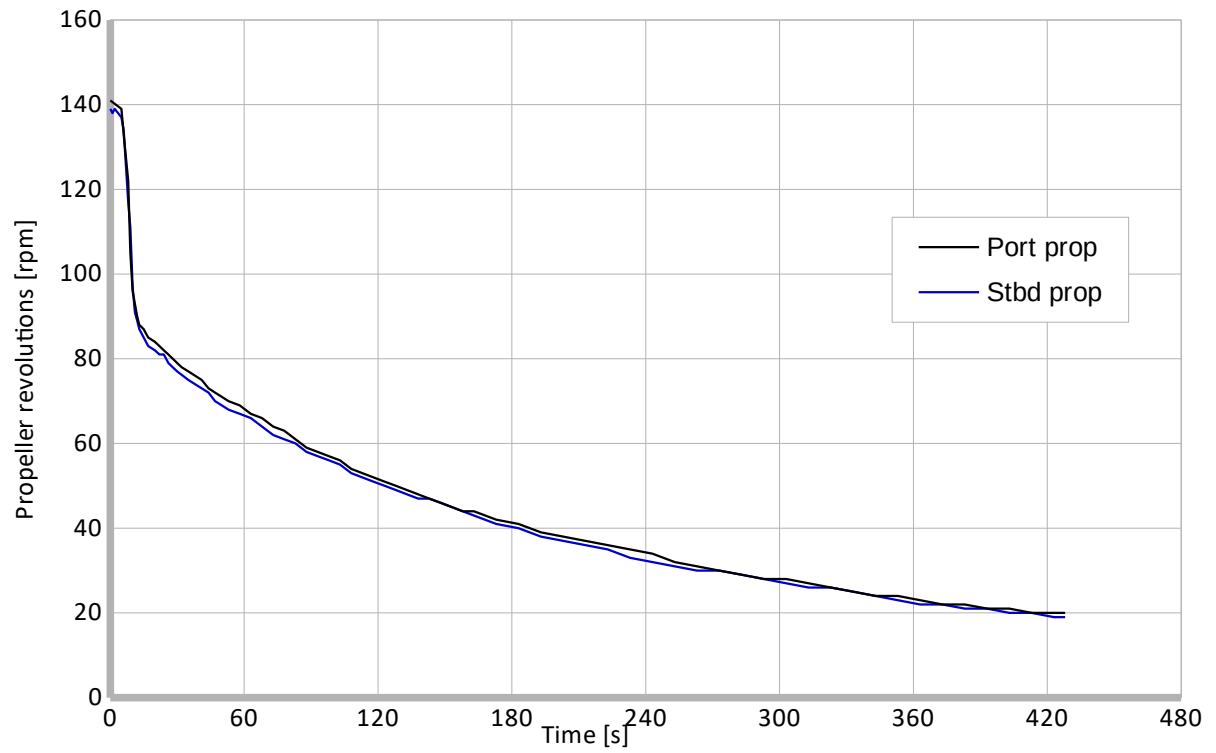

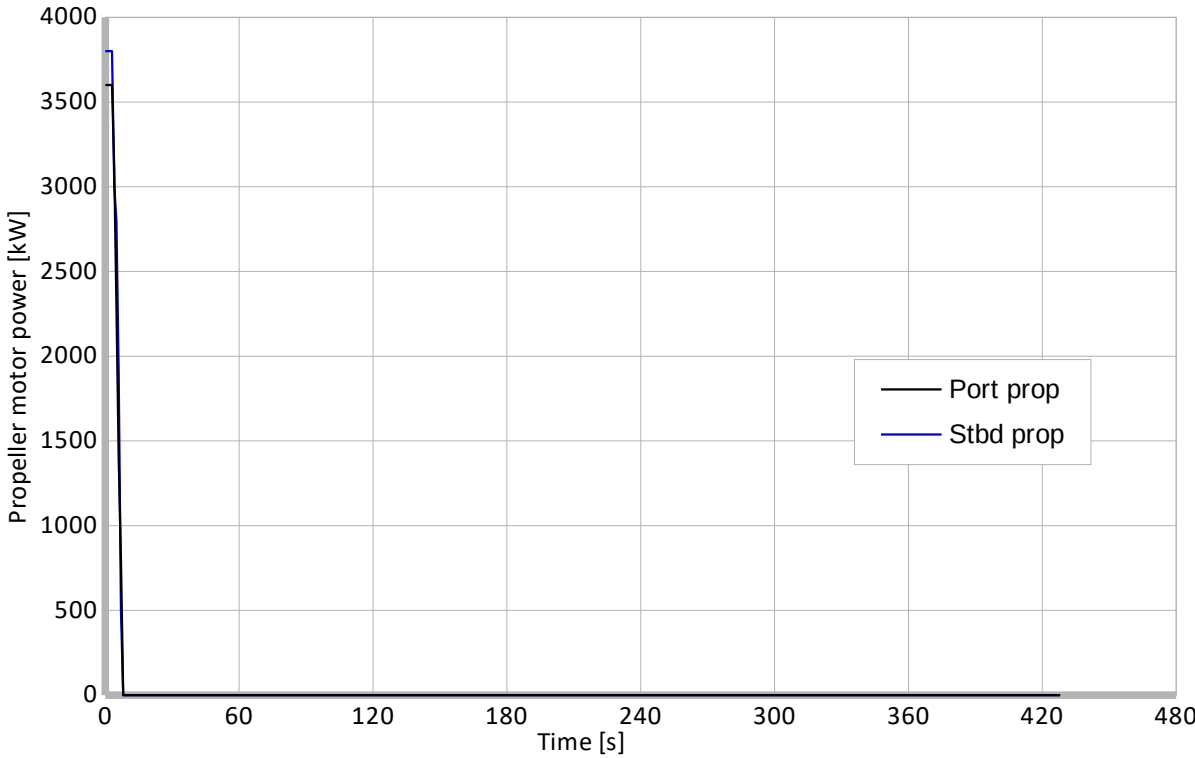
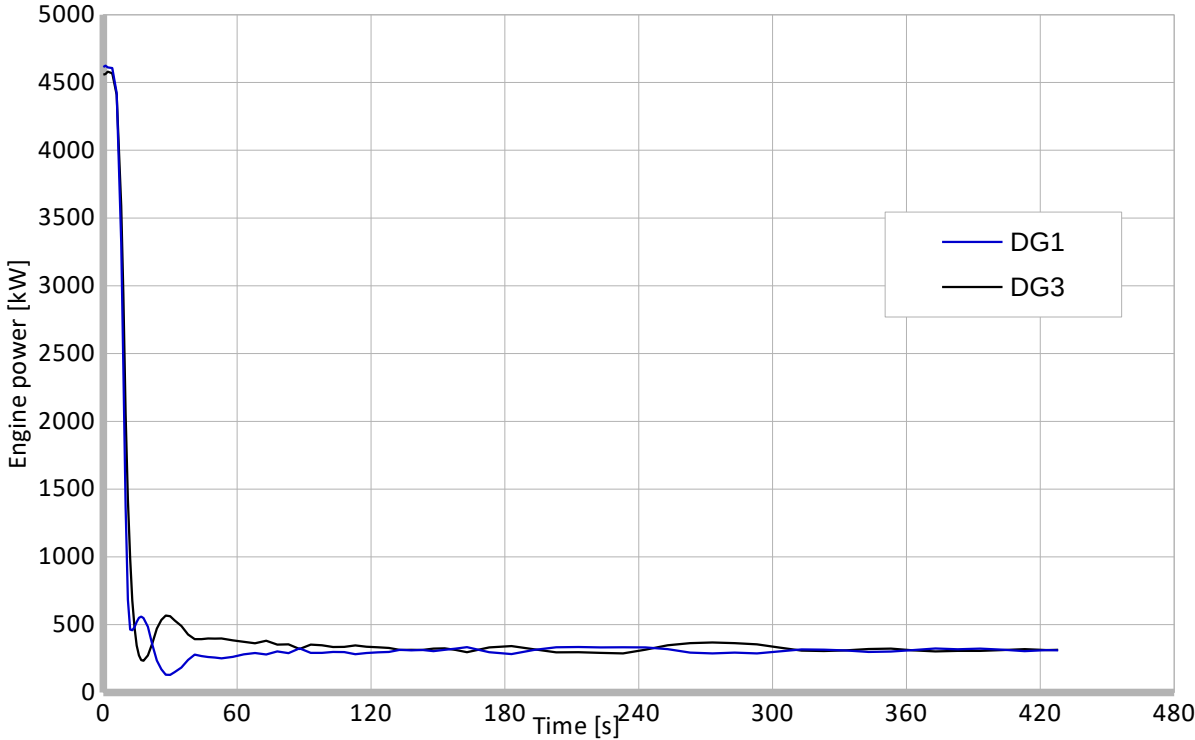

Acceleration test with 2+2 diesel generators

27.12.2014

Wind direction [deg]	20	Initial heading [deg]	212
Wind speed [m/s]	4	Time to reach 10 knots [s]	51
Initial speed [knots]	0,3	Time to reach 14 knots [s]	74

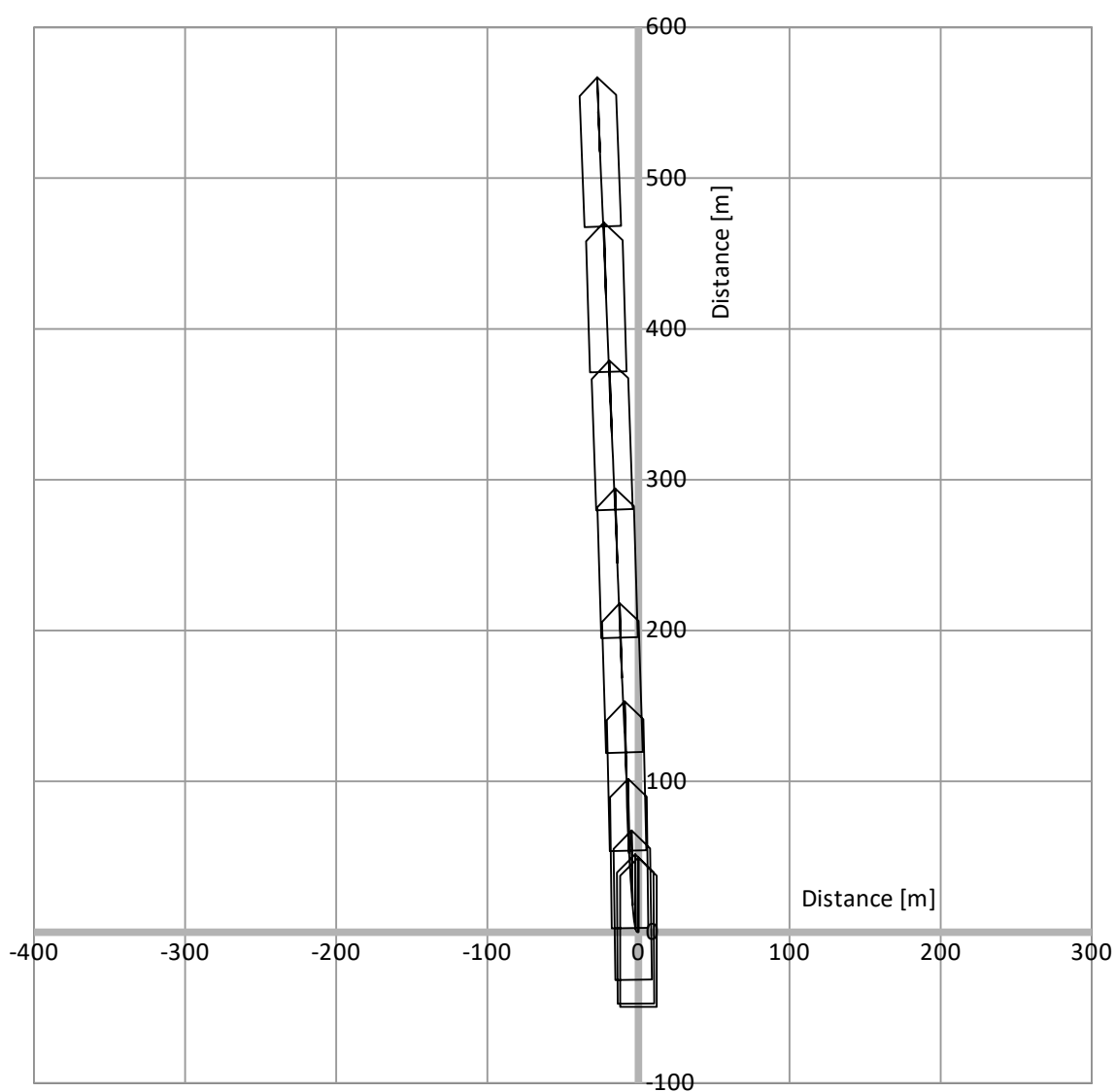

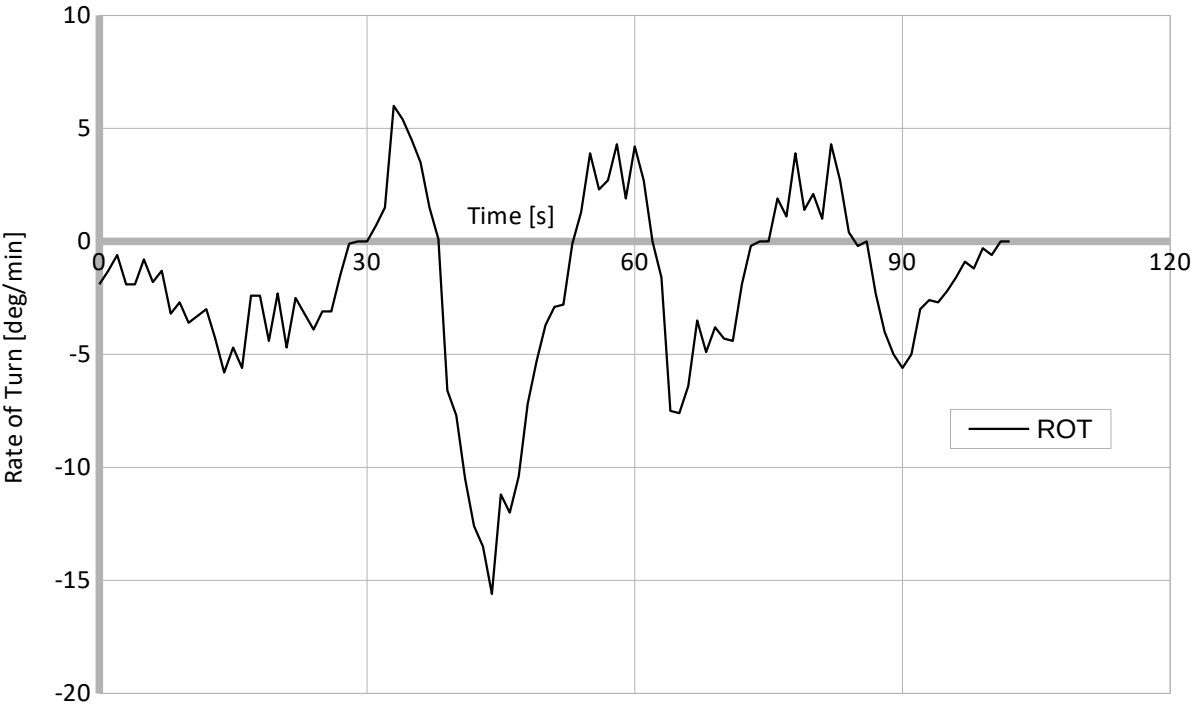
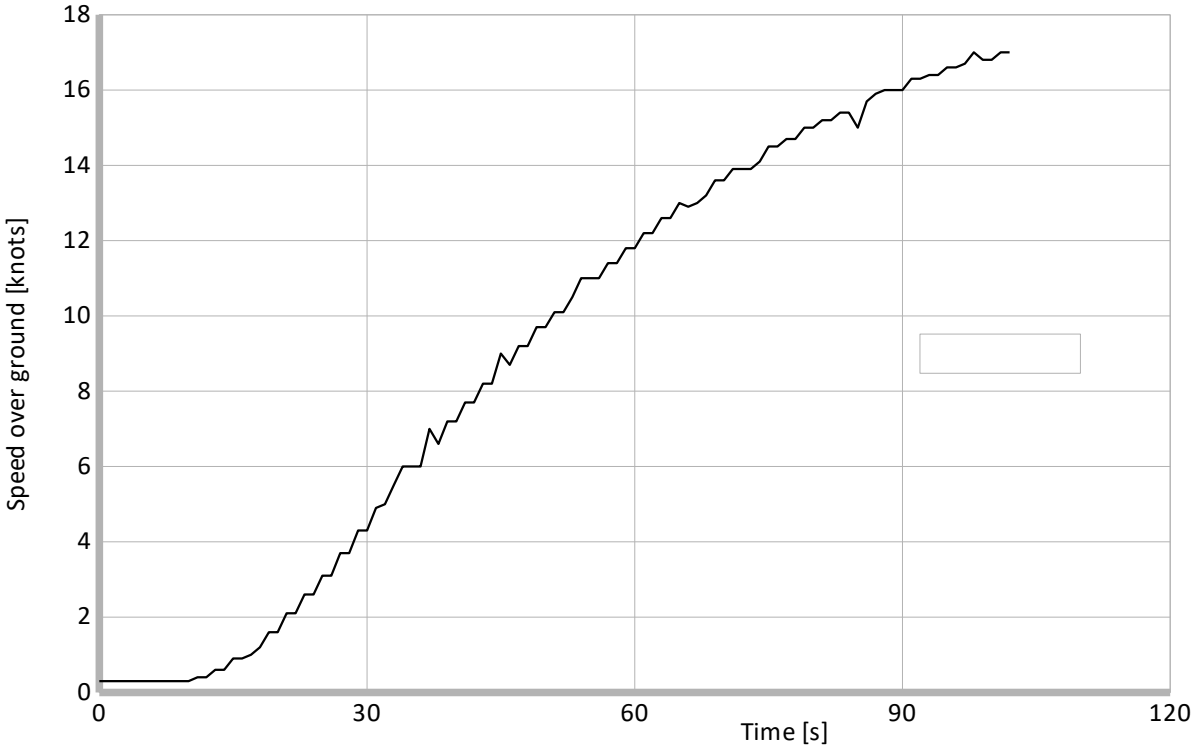

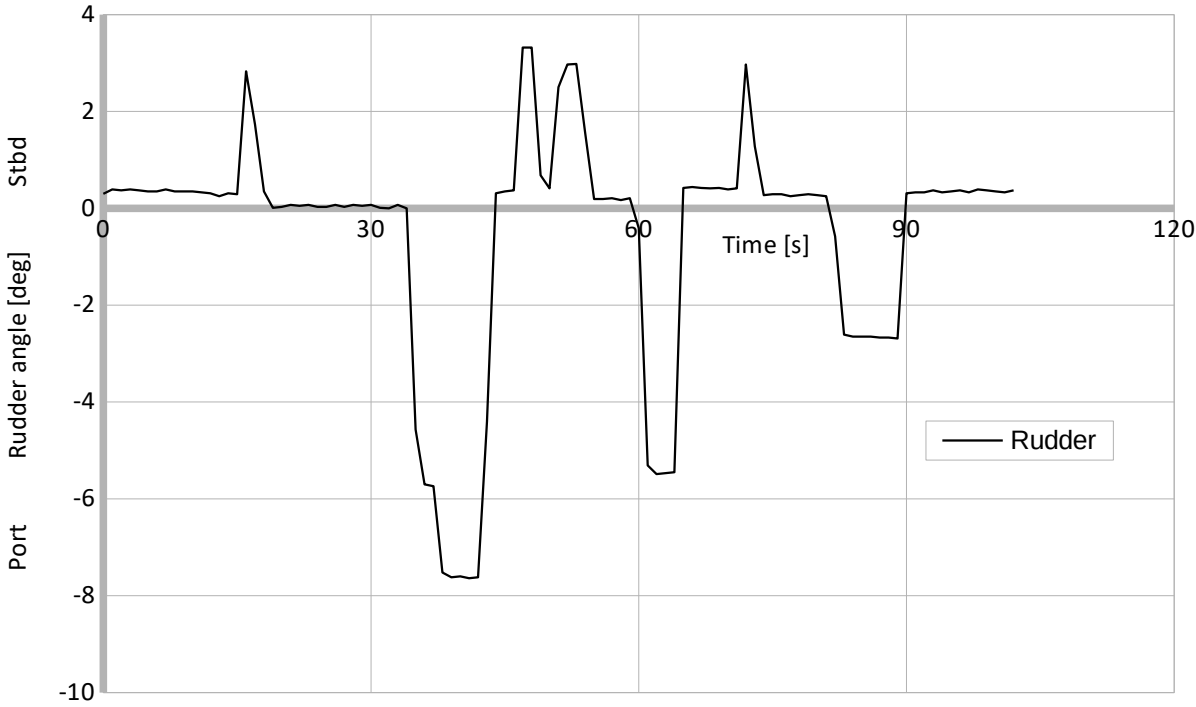
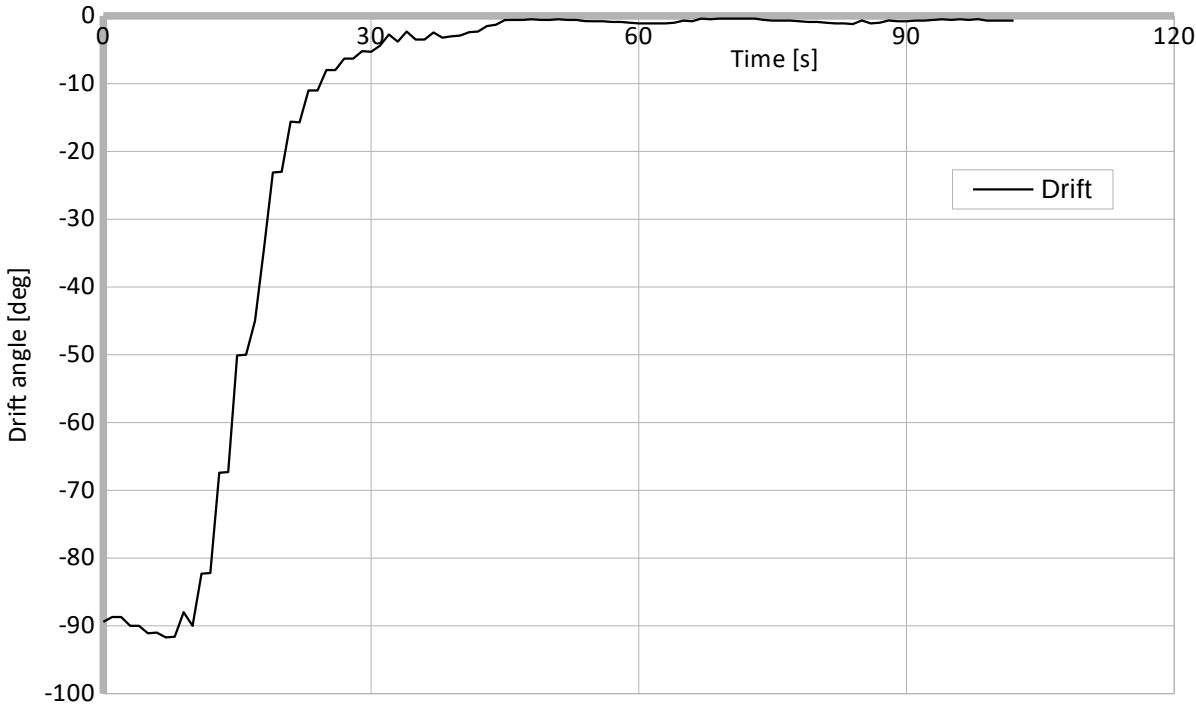

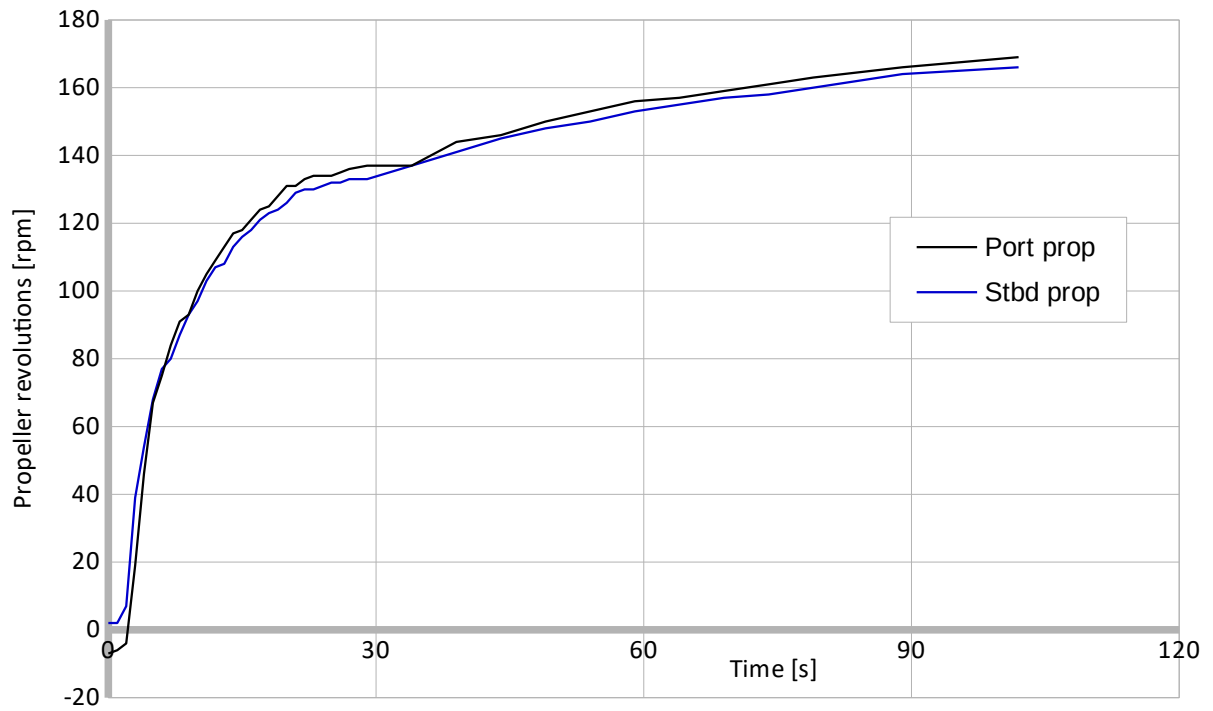

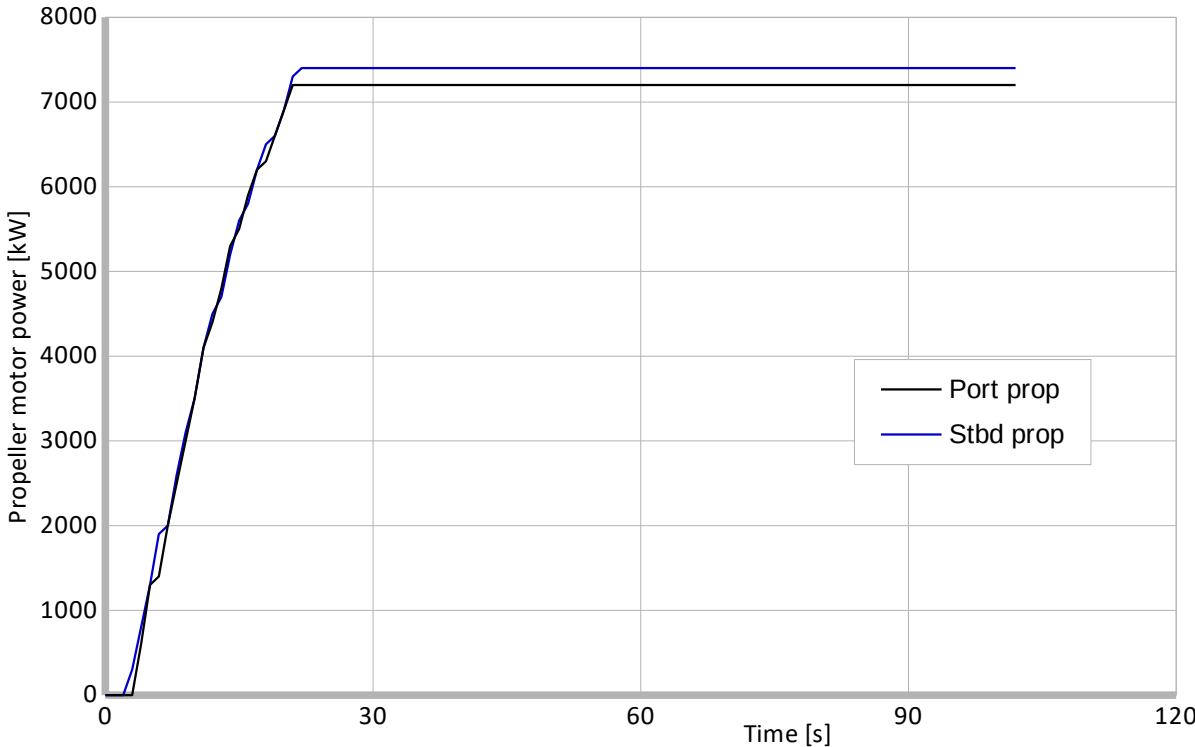
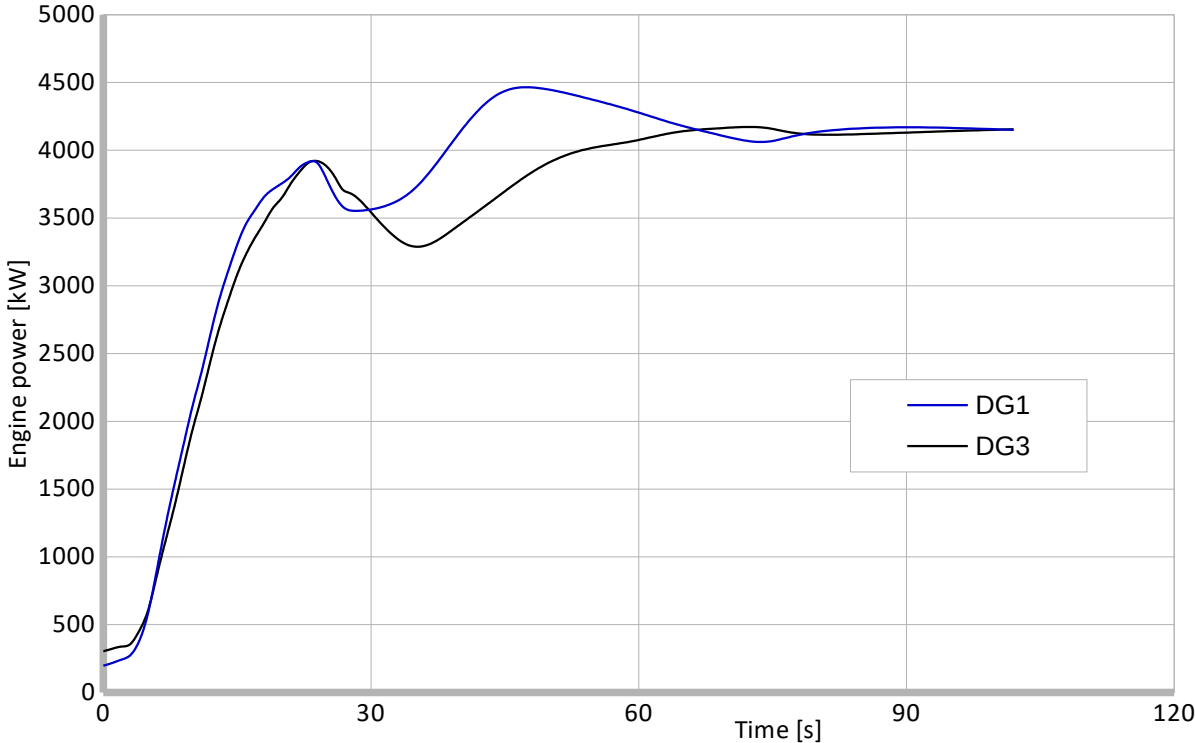

Deceleration test with 2+2 diesel generators

27.12.2014

Wind direction [deg]	20	Initial heading [deg]	210
Wind speed [m/s]	4	Initial speed [knots]	17,4

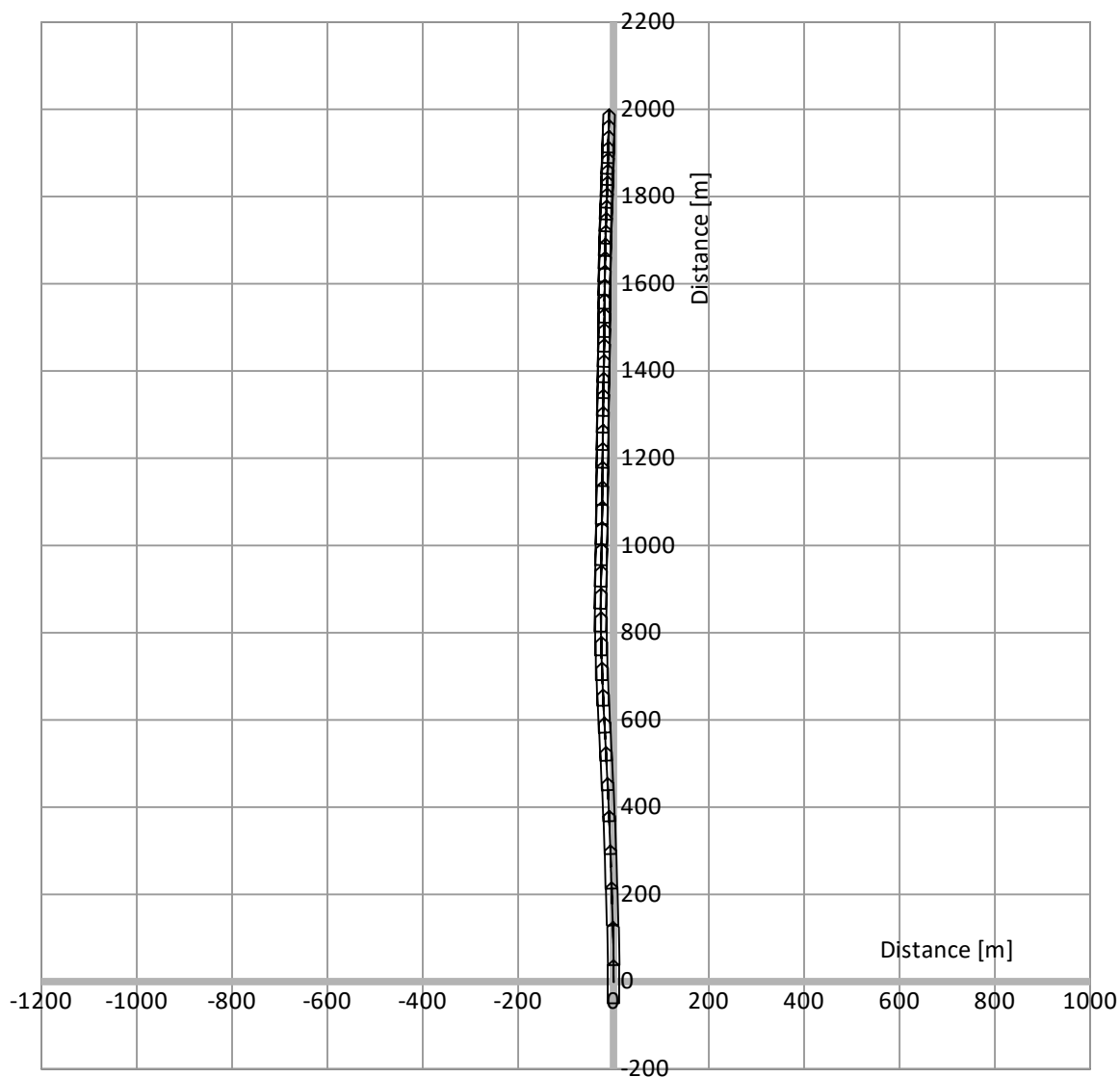

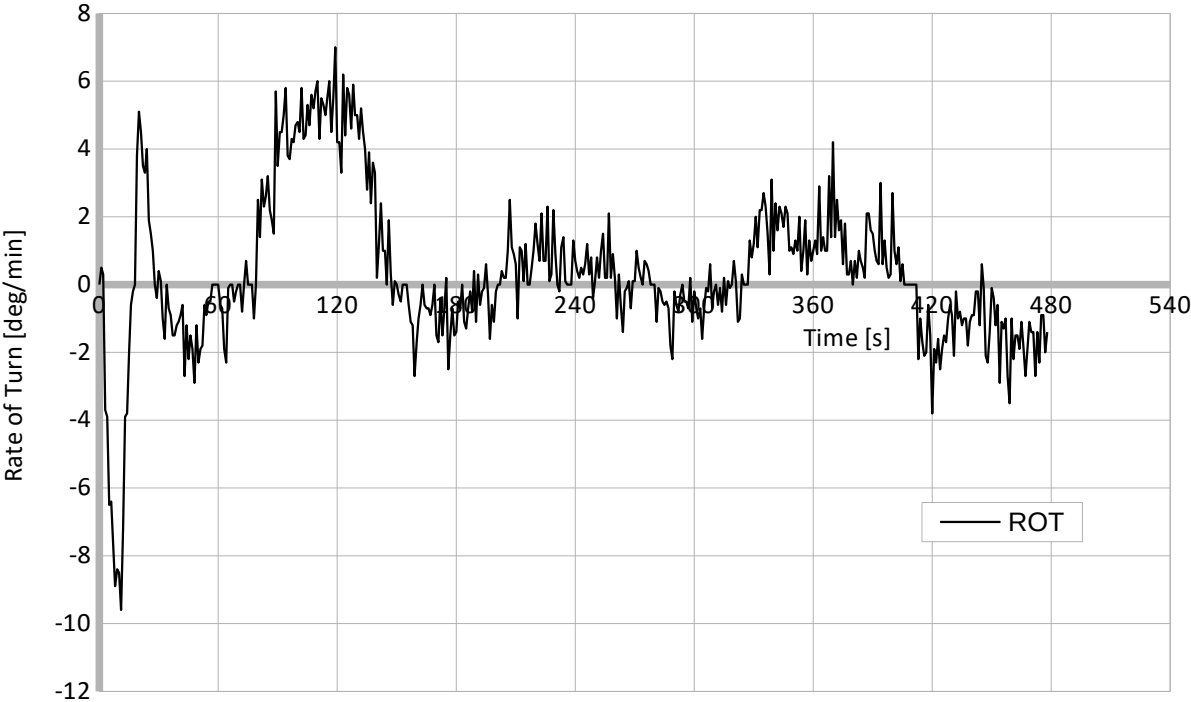
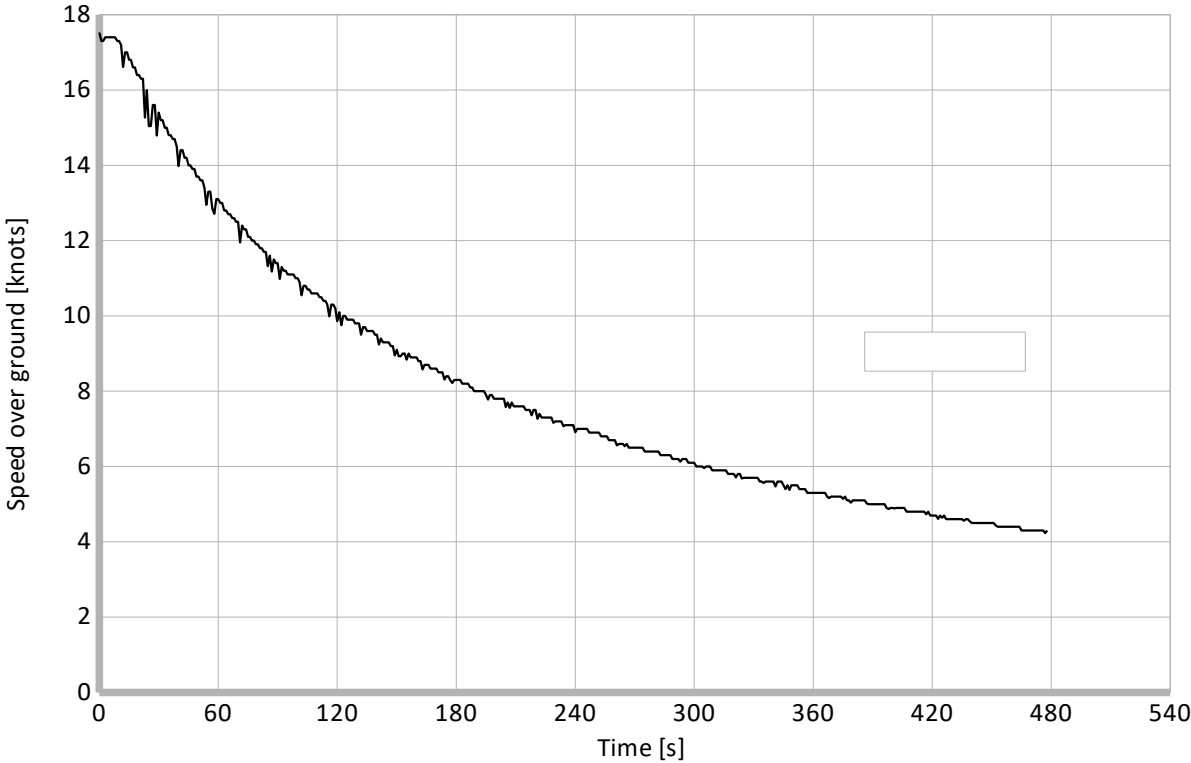

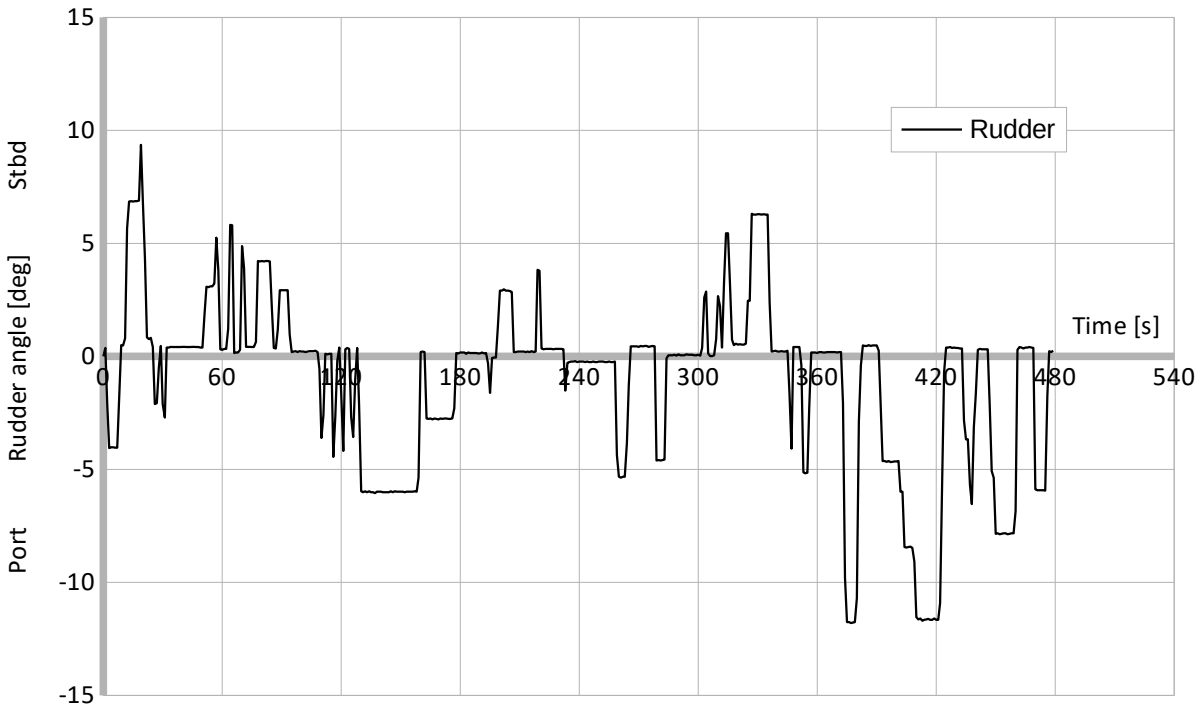
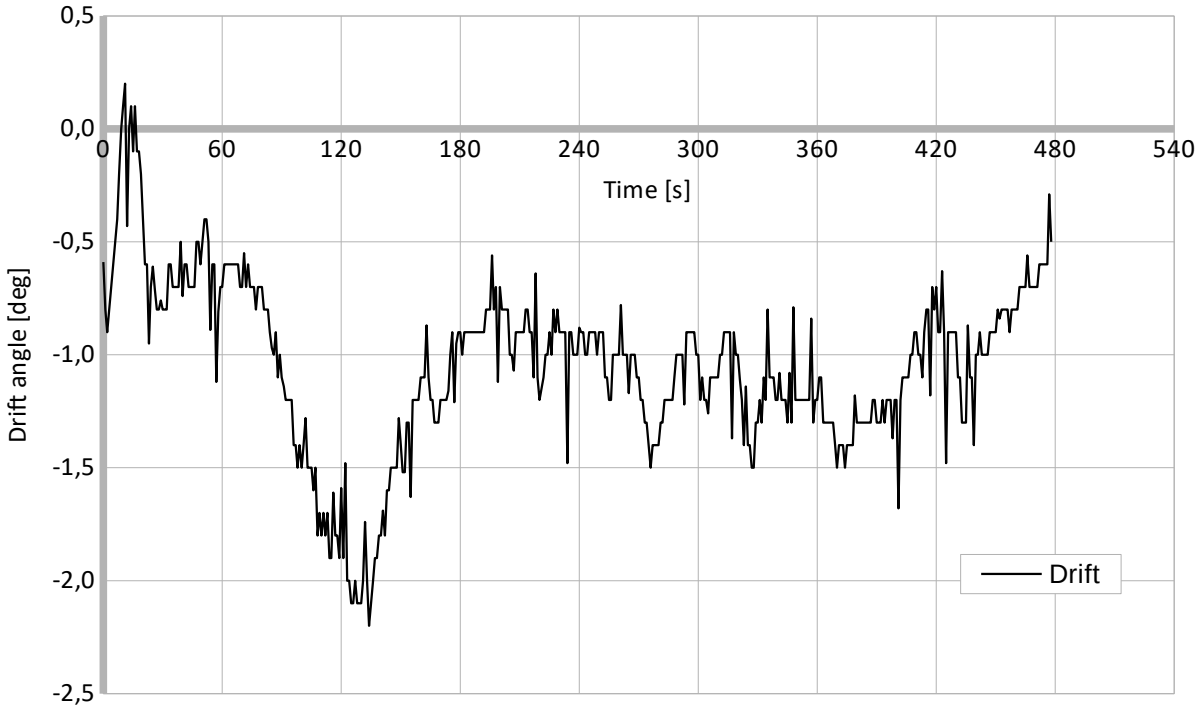

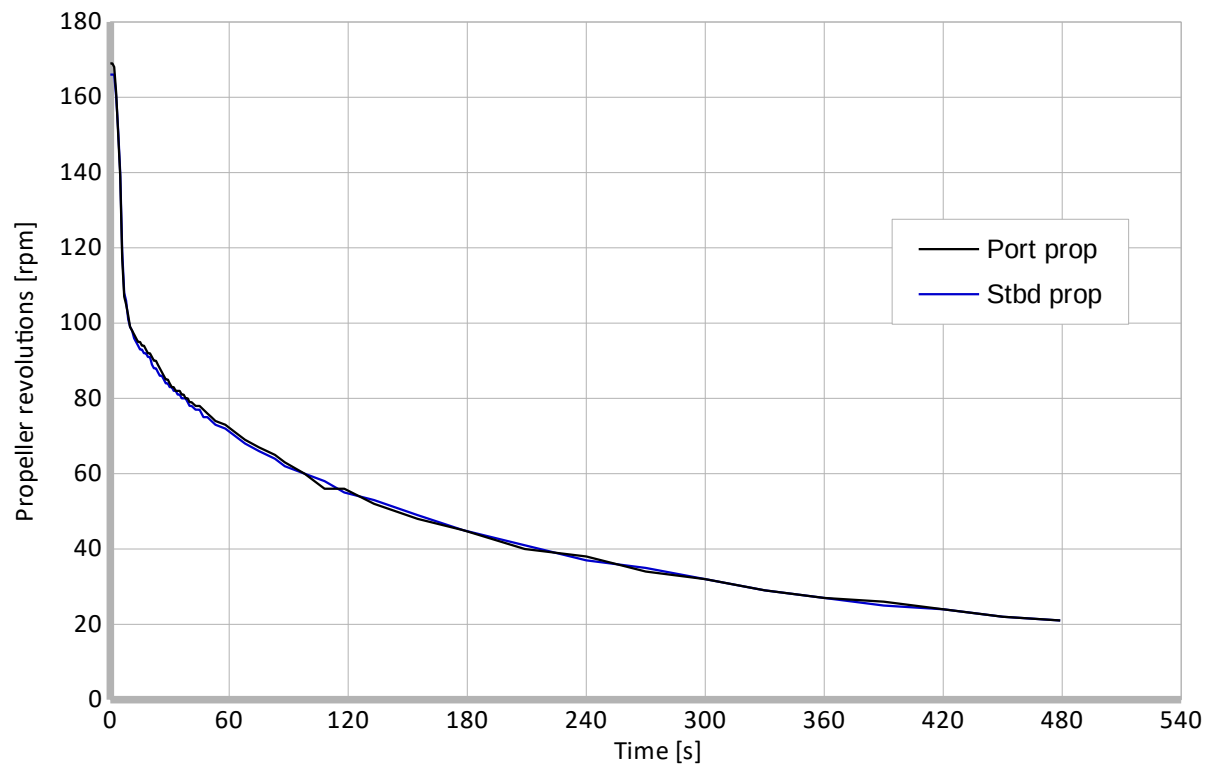

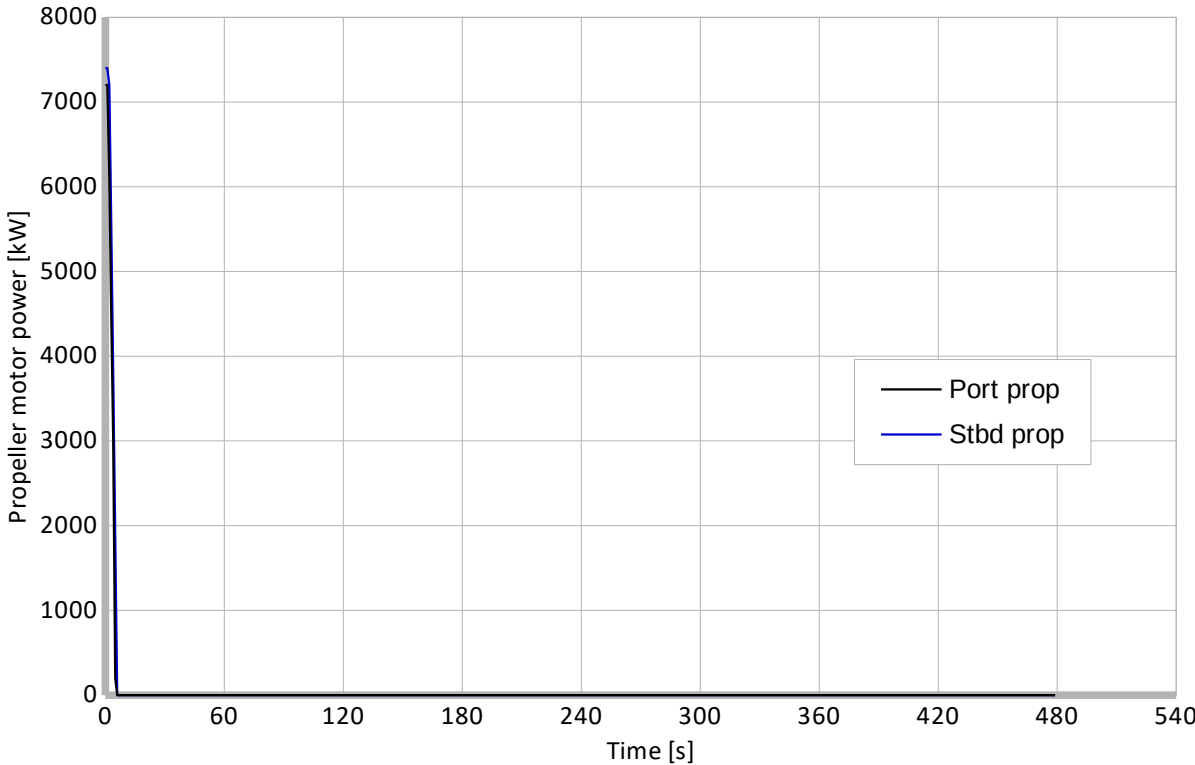
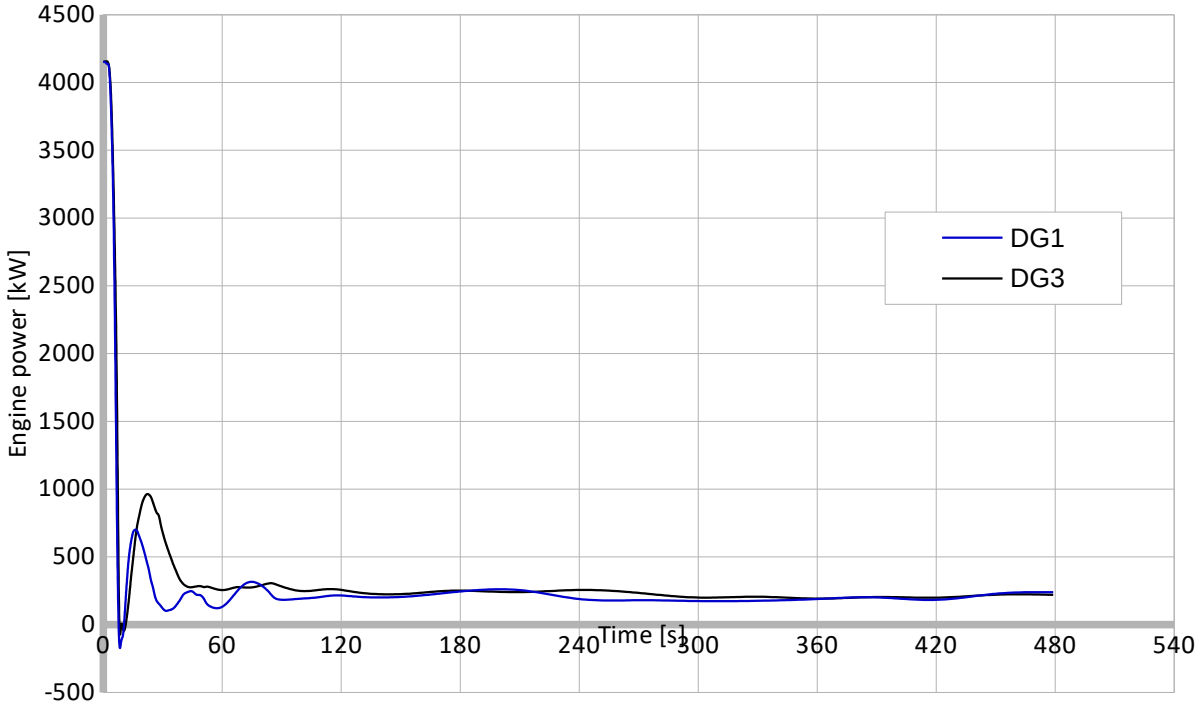

DEFINITIONS

Z-test	
Initial turning time	t1
First overshoot angle	a1
Time to check first yaw	t2
Second overshoot angle	a2
Time to check second yaw	t3
Time for complete cycle	t4
Turning rate	r

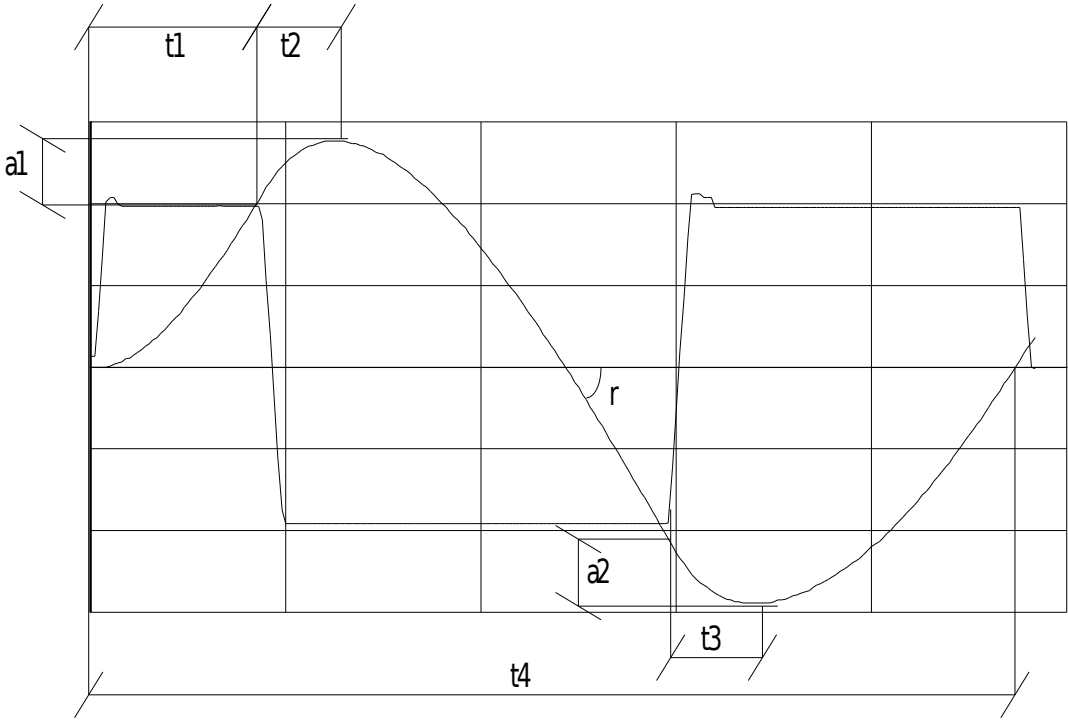

Turning circle	
Advance	X
Transfer	Y1
Tactical diameter	Y2
Steady diameter	D

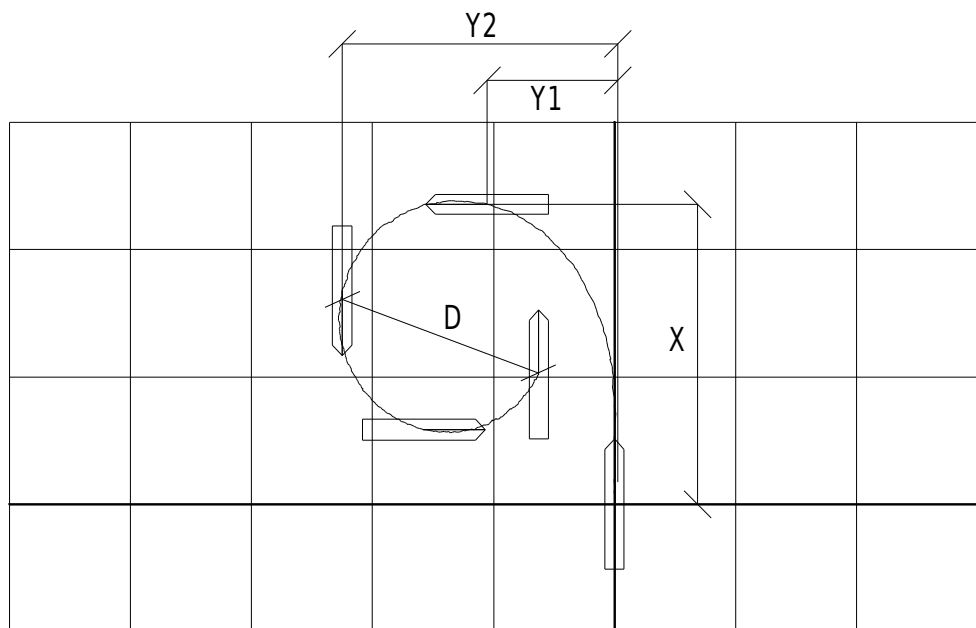

Crash stop	
Advance	X
Lateral transfer	Y

